

BOCK HGX2 CO₂ T

Assembly instructions

96458-01.2021-Gb

Translation of the original instructions

HGX2/70-4 CO₂ T

HGX2/90-4 CO₂ T

BOCK[®]

colour the world
of tomorrow

About these instructions

Read these instructions before assembly and before using the compressor. This will avoid misunderstandings and prevent damage. Improper assembly and use of the compressor can result in serious or fatal injury.

Observe the safety instructions contained in these instructions.

These instructions must be passed onto the end customer along with the unit in which the compressor is installed.

Manufacturer

Bock GmbH
72636 Frickenhausen

Contact

Bock GmbH
Benzstraße 7
72636 Frickenhausen
Germany

Phone +49 7022 9454-0
Fax +49 7022 9454-137
www.bock.de
service@bock.de

GB

Contents

Page

1	Safety	4
1.1	Identification of safety instructions	
1.2	Qualifications required of personnel	
1.3	Safety instructions	
1.4	Intended use	
2	Product description	6
2.1	Short description	
2.2	Name plate	
2.3	Type key	

Contents

Page

3	Areas of application	8
3.1	Refrigerants	
3.2	Oil charge	
3.3	Limits of application	
4	Compressor assembly	10
4.1	Storage and transportation	
4.2	Setting up	
4.3	Connecting the pipelines - solder system	
4.4	Connecting the pipelines - cutting ring system	
4.5	Pipes	
4.6	Flange shut-off valves (HP/LP)	
4.7	Option: cutting ring screw joint (HP/LP)	
4.8	Laying suction and pressure lines	
4.9	Operating the shut-off valves	
4.10	Operating mode of the lockable service connections	
4.11	Suction pipe filter	
5	Electrical connection	15
5.1	Information for contactor and motor contactor selection	
5.2	Standard motor, designed for direct or part winding start	
5.3	Basic circuit diagram for part winding start	
5.4	Electronic trigger unit INT69 G	
5.5	Connection of the electronic trigger unit INT69 G	
5.6	Functional test of the electronic trigger unit INT69 G	
5.7	Oil sump heater	
6	Commissioning	22
6.1	Preparations for start-up	
6.2	Pressure strength test	
6.3	Leak test	
6.4	Evacuation	
6.5	Refrigerant charge	
6.6	Start-up	
6.7	Pressure switch	
6.8	Decompression valves	
6.9	Avoiding slugging	
6.10	Filter dryer	
7	Maintenance	26
7.1	Preparation	
7.2	Work to be carried out	
7.3	Spare parts recommendation/accessories	
7.4	Lubricants	
7.5	Decommissioning	
8	Technical data	28
9	Dimensions and connections	29
10	Declaration of incorporation	31
11	Service	32

GB

1| Safety

1.1 Identification of safety instructions:



DANGER

Indicates a dangerous situation which, if not avoided, will cause immediate fatal or serious injury



WARNING

Indicates a dangerous situation which, if not avoided, may cause fatal or serious injury



CAUTION

Indicates a dangerous situation which, if not avoided, may immediately cause fairly severe or minor injury.



ATTENTION

Indicates a situation which, if not avoided, may cause property damage



INFO

Important information or tips on simplifying work

GB

1.2 Qualifications required of personnel



WARNING

Inadequately qualified personnel poses the risk of accidents, the consequence being serious or fatal injury. Work on compressors must therefore only be performed by personnel with the qualifications listed below:

- For example, a refrigeration technician, refrigeration mechatronics engineer. As well as professions with comparable training, which enable personnel to assemble, install, maintain and repair refrigeration and air-conditioning systems. Personnel must be capable of assessing the work to be carried out and recognising any potential dangers.

1| Safety

1.3 Safety instructions



WARNING

Risk of accident.

Refrigerating compressors are pressurised machines and therefore require particular caution and care in handling.

The maximum permissible overpressure must not be exceeded, even for testing purposes.

Risk of burns!

- Depending on the operating conditions, surface temperatures of over 60 °C on the pressure side or below 0 °C on the suction side can be reached.
- Avoid the contact with refrigerant under any circumstances. The contact with refrigerant can lead to severe burns and skin irritations.

Danger of suffocation.

CO₂ is a nonflammable, acidic, colorless and odorless gas and heavier than air.

Never release significant volumes of CO₂ or the entire contents of the system into closed rooms!

Safety installations are designed or adjusted in accordance with EN 378-2 or appropriate safety standards.

- Transcritical CO₂ applications are still in the development phase.
- They require a completely new kind of system and control.
- They are not a general solution for the substitution of F-gases.
- Therefore, we expressly point out that all information in this assembly instruction has been provided according to our current level of knowledge and may change due to further development. Legal claims based on the correctness of the information cannot be made at any time and are hereby expressly excluded.

GB

1.4 Intended use



WARNING

The compressor may not be used in potentially explosive environments!

These assembly instructions describe the standard version of the compressors named in the title manufactured by Bock. Bock refrigerating compressors are intended for installing in a machine (within the EU according to the EU Directives 2006/42/EC Machinery Directive and 2014/68/EU Pressure Equipment Directive).

Commissioning is only permissible if the compressors have been installed in accordance with these assembly instructions and the entire system into which they are integrated has been inspected and approved in accordance with legal regulations.

The compressors are intended for use with CO₂ in transcritical and/or subcritical systems in compliance with the limits of application.

Only the refrigerant specified in these instructions may be used.

Any other use of the compressor is prohibited!

2 | Product description

2.1 Short description

- Semi-hermetic two-cylinder reciprocating compressor with suction gas-cooled drive motor.
- The refrigerant coming from the evaporator is entering the compressor and flowing over the motor. This ensures an especially intensive cooling of the motor. Therefore the motor temperature remains on a relatively low level - especially at high load.
- Oil pump independent of direction of rotation for reliable and safe oil supply.
- One decompression valve each on the low and high pressure side, which vent into the atmosphere when these inadmissibly high printing pressures are reached.

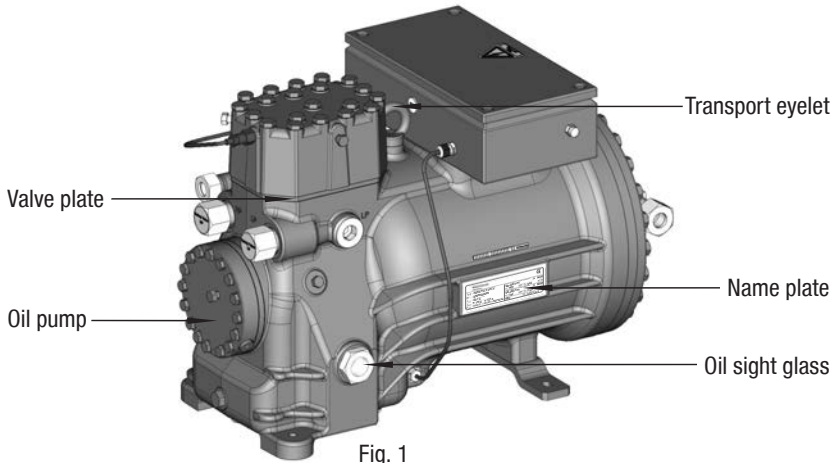

Fig. 1

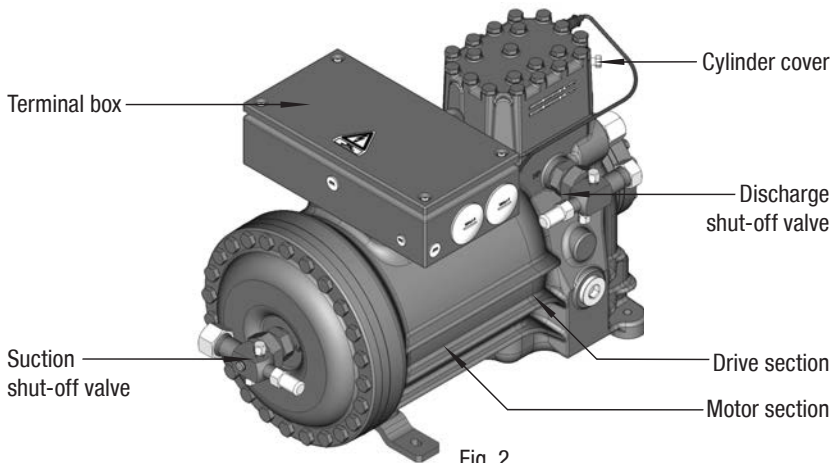

Fig. 2

Dimension and connection values can be found in Chapter 9

2 | Product description

2.2 Name plate (example)

BOCK		Bock GmbH, Benzstr. 7 72636 Frickenhausen, Germany		CE	
1	Typ : HGX2/90-4 CO ₂ T	380-420V Y/YY	-3-	50HZ	6
2	Nr. : AZ30046A002	n : 1450 min ⁻¹	V _{th} : 7,70	m ³ /h	7
3	I _{max} : 23,8 A	440-480V Y/YY	-3-	60HZ	8
4	I _{block} : Y: 87 A Y: 149 A	n : 1740 min ⁻¹	V _{th} : 9,30	m ³ /h	9
5	p _{max} : ND(LP) / HD(HP)=100/150 bar	IP65	Öl : CO2,C 85 E		10
					11
					12
					13

Fig. 3

1	Type designation	6	Voltage, circuit, frequency	} 50 Hz
2	Machine number	7	Nominal rotation speed	
3	maximum operating current	8	Displacement	} 60 Hz
4	Starting current (rotor blocked) Y: Part winding 1 YY: Part winding 1 and 2	9	Voltage, circuit, frequency	
		10	Nominal rotation speed	
5	ND (LP): max. permissible operating pressure (g) Low pressure side HD (HP): max. permissible operating pressure (g) High pressure side	11	Displacement	
		12	Oil type filled at the factory	
		13	Terminal box protection type	

i Observe the limits of application diagrams!

i Electrical accessories can change the IP protection class!

GB

2.3 Type key (example)

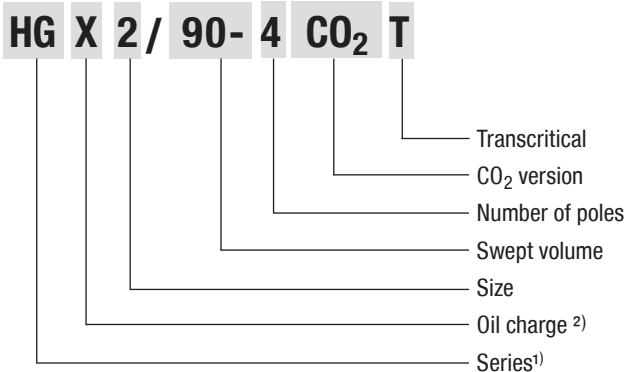

¹⁾ HG - Hermetic Gas-Cooled (suction gas-cooled)

²⁾ X - Ester oil charge

3 | Areas of application

3.1 Refrigerants

- CO₂: R744 (Recommendation CO₂ quality 4.5 (< 5 ppm H₂O))

3.2 Oil charge

- The compressors are filled at the factory with the following oil type:
Bock C 85 E (only this oil may be used).



ATTENTION Property damage possible.

The oil level must be in the visible part of the sight glass; damage to the compressor is possible if overfilled or underfilled!

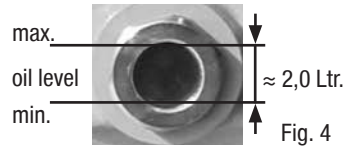

3.3 Limits of application



ATTENTION Compressor operation is possible within the operating limits. These can be found in Bock compressor selection tool (VAP) under vap.bock.de. Observe the information given there.

- Permissible ambient temperature (-20 °C) - (+60 °C).
- Max. permissible discharge end temperature 160 °C.
- Min. discharge end temperature ≥ 50 °C.
- Min. oil temperature ≥ 30 °C.
- Max. permissible switching frequency 12x / h.
- A minimum running time of 3 min. steady-state condition (continuous operation) must be achieved.

For operation with supplementary cooling:

- Use only oils with high thermal stability.
- Avoid continuous operation near the threshold.

For operation with frequency converter:

- Frequency range 30 - 60 Hz.
- The maximum current and power consumption must not be exceeded. In the case of operation above the mains frequency, the application limit can therefore be limited.

3 | Areas of application

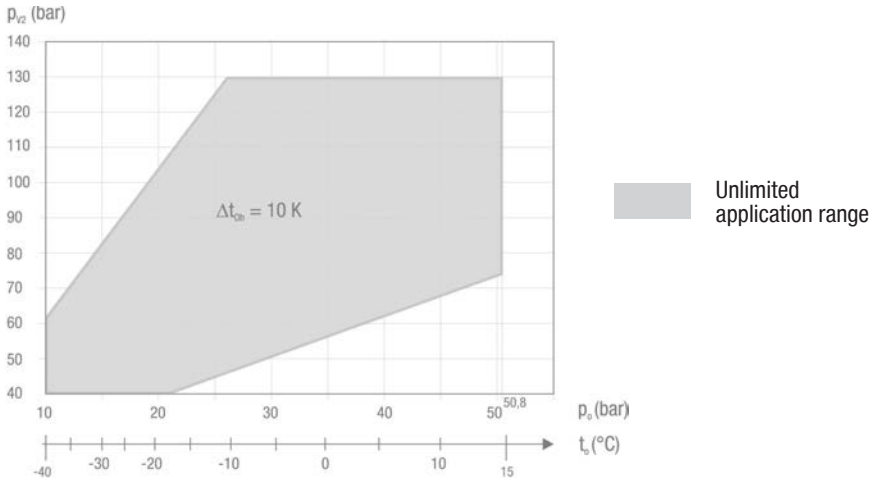

Fig. 5

- t_o Evaporation temperature (°C)
- Δt_{oh} Suction gas superheat (K)
- p_o Suction pressure (bar)
- p_{v2} Discharge end pressure (bar)

Max. permissible operating pressure (LP/HP)¹⁾: 100/150 bar

- ¹⁾ LP = Low pressure
- HP = High pressure

GB

4 | Compressor assembly



INFO

New compressors are factory-filled with inert gas. Leave this service charge in the compressor for as long as possible and prevent the ingress of air.

Immediately after cooling technical connection of the compressor of shutoff devices in suction-, discharge-, oil return line etc. close and compressors evacuate.

Check the compressor for transport damage before starting any work.

4.1 Storage and transportation



Fig. 6

- Storage at (-30 °C) - (+70 °C), maximum permissible relative humidity 10 % -95 %, no condensation.
- Do not store in a corrosive, dusty, vaporous atmosphere or in a combustible environment.



Fig. 7

- Use transport eyelet.
- Do not lift manually!
- Use lifting gear!

GB

4.2 Setting up



ATTENTION

Attachments (e.g. pipe holders, additional units, fastening parts, etc.) directly to the compressor are not permissible!

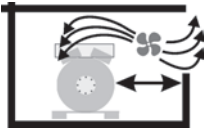

Fig. 8

- Provide adequate clearance for maintenance work.
- Ensure adequate compressor ventilation.



Fig. 9

- Do not use in a corrosive, dusty, damp atmosphere or a combustible environment.

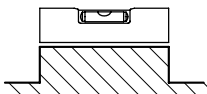

Fig. 10

- Setup on an even surface or frame with sufficient load-bearing capacity.
- Single compressor preferably on vibration damper.
- Compound connection basically rigid.

4| Compressor assembly

4.3 Connecting the pipelines - solder system



ATTENTION Damage possible.

Superheating can damage the valve.

Remove the pipe supports therefore from the valve for soldering and accordingly cool the valve body during and after soldering.

Only solder using inert gas to inhibit oxidation products (scale).

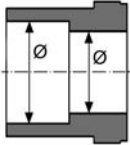

Fig. 11: graduated internal diameter

- **Material soldering / welding connection: S235 (JRG2C)**
- The **pipe connections** have graduated inside diameters so that pipes with standart millimetre and inch dimensions can be used.
- The connection diameters of the shut-off valves are rated for maximum compressor output. **The actual required pipe cross section must be matched to the output. The same applies for non-return valves.**

4.4 Connecting the pipelines - cutting ring system

- On its high-pressure side, the compressor has a shut-off valve with multi-sided cutting ring for safe installation of the discharge line.

Cutting ring function before tightening the union nut

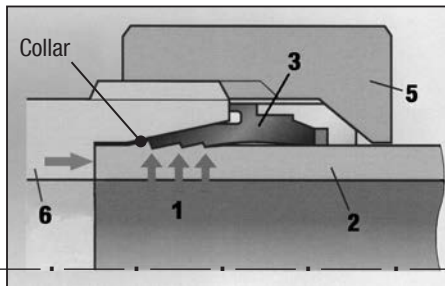

Fig. 12
Figure similar

GB

Tube preparation:

The tube has to be sawn in a right angle. An angular tolerance of $\pm 1^\circ$ is permissible.

Slightly trim the pipe ends inside and outside. For thin walled steel pipes or soft pipes made of nonferrous metal, reinforcing sleeves have to be used.

Pipe assembly:

Push Union Nut (5) and Cut Ring (3) onto Pipe (2). Insert pipe into Socket (6) as far as it will go and firmly press against pipe stop, otherwise incorrect assembly. Hand tighten union nut until socket, cutting ring and union nut are locked. Tighten union nut $1 \frac{1}{2}$ turns using a spanner wrench. The cutting ring is noticeably locked to the socket face (for assembly inside pipe connection, hold up valve with a spanner wrench). This should cause the cutting ring with its cutting edges to cut into the pipe resulting in a visible collar. In order to stick to the turns we recommend using marking lines on union nut and pipe. After assembly, it is necessary to check the collar. The gasket must not be damaged. At least 80 % of the cutting face has to be covered. After check-up, screw on and tighten again as described above.

4| Compressor assembly

4.5 Pipes

- Pipes and system components must be clean and dry inside and free of scale, swarf and layers of rust and phosphate. Only use hermetically sealed parts.
- Lay pipes correctly. Suitable vibration compensators must be provided to prevent pipes being cracked and broken by severe vibrations.
- Ensure a proper oil return.
- Keep pressure losses to an absolute minimum.

4.6 Flange shut-off valves (HP/LP)



CAUTION Risk of injury.

The compressor must be depressurised through connections A and B before commencing any work and prior to connecting to the refrigerant system.

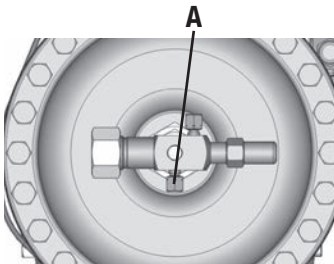

Fig. 13

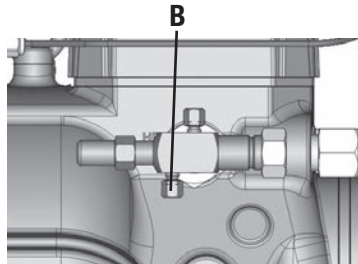

Fig. 14

4.7 Option: cutting ring screw joint (HP/LP)



ATTENTION Property damage possible.

The compressor as delivered is equipped with Schrader valves on the high and low pressure connections. These are used exclusively for changing with inert gas in the factory, and under no circumstances may they be connected to the refrigeration circuit (the Schrader valves are approved for overpressure up to 28 bar only)!

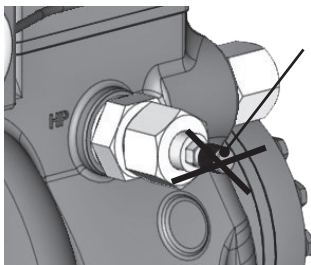

Fig. 15

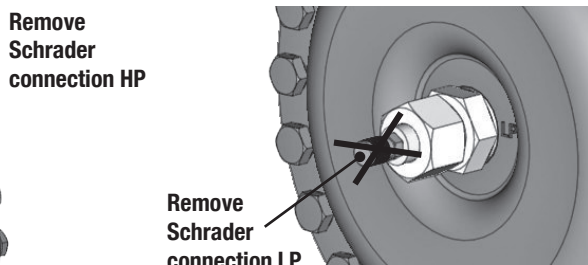

Fig. 16

4 | Compressor assembly

4.8 Laying suction and pressure lines



ATTENTION Property damage possible.

Improperly installed pipes can cause cracks and tears which can result in a loss of refrigerant.



INFO

Proper layout of the suction and pressure lines directly after the compressor is integral to the smooth running and vibration behaviour of the system.

A rule of thumb:

Always lay the first pipe section starting from the shut-off valve **downwards and parallel to the drive shaft**.

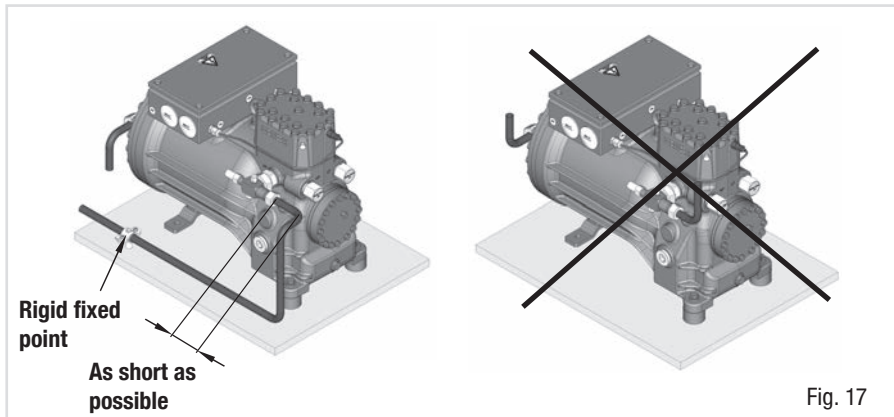

Fig. 17

GB

4.9 Operating the shut-off valves

- Before opening or closing the shut-off valve, release the valve spindle seal by approx. $\frac{1}{4}$ of a turn counter-clockwise.
- After activating the shut-off valve, re-tighten the adjustable valve spindle seal clockwise.

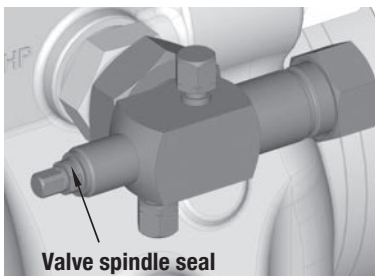

Fig. 18

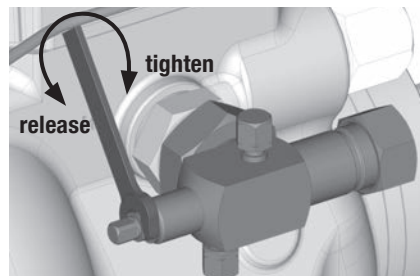

Fig. 19

4 | Compressor assembly

4.10 Operating mode of the lockable service connections

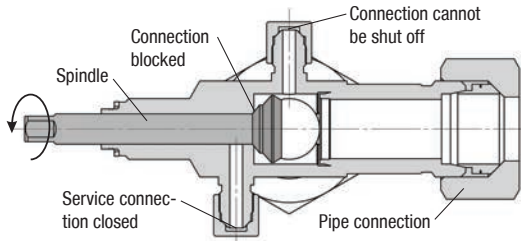

Fig. 20

Opening the shut-off valve:

Spindle: turn to the left (counter-clockwise) as far as it will go.

—> Shut-off valve completely opened / service connection closed.

The connection which cannot be shut off is intended for safety devices.

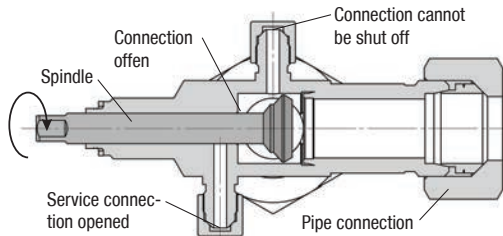

Fig. 21

Opening the service connection

Spindle: Turn $1/2$ - 1 turn to the right clockwise.

—> Service connection opened / shut-off valve opened.

The connection which cannot be shut off is intended for safety devices.

After activating the spindle, generally fit the spindle protection cap again and tighten with 40 - 50 Nm. This serves as a second sealing feature during operation.

4.11 Suction pipe filter

For systems with long pipes and higher degree of contamination, a filter on the suction-side is recommended. The filter has to be renewed depending on the degree of contamination (reduced pressure loss).

5 | Electrical connection

5 Electrical connection



DANGER

Risk of electric shock! High voltage!

Only carry out work when the electrical system is disconnected from the power supply!



ATTENTION

When attaching accessories with an electrical cable, a minimum bending radius of 3 x the cable diameter must be maintained for laying the cable.



INFO

Connect the compressor motor in accordance with the circuit diagram (see inside of terminal box).

- Use suitable cable entry point of the correct protection type (see name plate) for routing cables into the terminal box. Insert the strain reliefs and prevent chafe marks on the cables.
- Compare the voltage and frequency values with the data for the mains power supply.

Only connect the motor if these values are the same.

5.1 Information for contactor and motor contactor selection

All protection equipment, switching and monitoring devices must comply with the local safety regulations and established specifications (e.g. VDE) as well as the manufacturer's specifications.

Motor protection switches are required! Motor contactors, feed lines, fuses and motor protection switches must be rated according to the maximum operating current (see name plate). For motor protection, use a current-independent, time-delayed overload protection device for monitoring all three phases. Adjust the overload protection device so that it must be actuated within 2 hours at 1.2 times the maximum working current.

GB

5 | Electrical connection

5.2 Standard motor, designed for direct or part winding start

Designation on the name plate	Sticker on the terminal box
Y/YY	

Compressors marked in this way are suitable for direct or part winding start. The motor winding is divided into two parts: part winding 1 = 50 % and part winding 2 = 50 %. This winding deviation reduces the start-up current during a part winding start to approx. 50 % of the value for a direct start.



INFO

Mechanical start unloader with bypass solenoid is not required.

5 | Electrical connection

In the factory, the motor is switched for direct starting (YY). For part winding start (Y/YY), remove the bridges and connect the motor feed cable according to the circuit diagram:

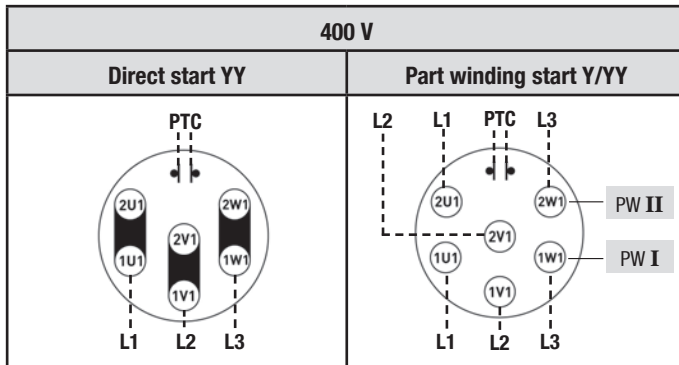

ATTENTION Property damage possible.

Failure to comply results in reversed fields of rotation and can cause motor damage. After the motor has started up with part winding 1, part winding 2 must be switched on after max. 1 second delay. Failure to comply can be detrimental to the service life of the motor.

Ensure that power is supplied via QA2 to winding 1 (50 %) (1U1 / 1V1 / 1W1) and via QA3 to winding 2 (50 %) (2U1 / 2V1 / 2W1). The motor contactors (QA2/QA3) are each to be rated for approx. 50 % of the max. operating current.

GB

5 | Electrical connection

5.3 Basic circuit diagram for part winding start

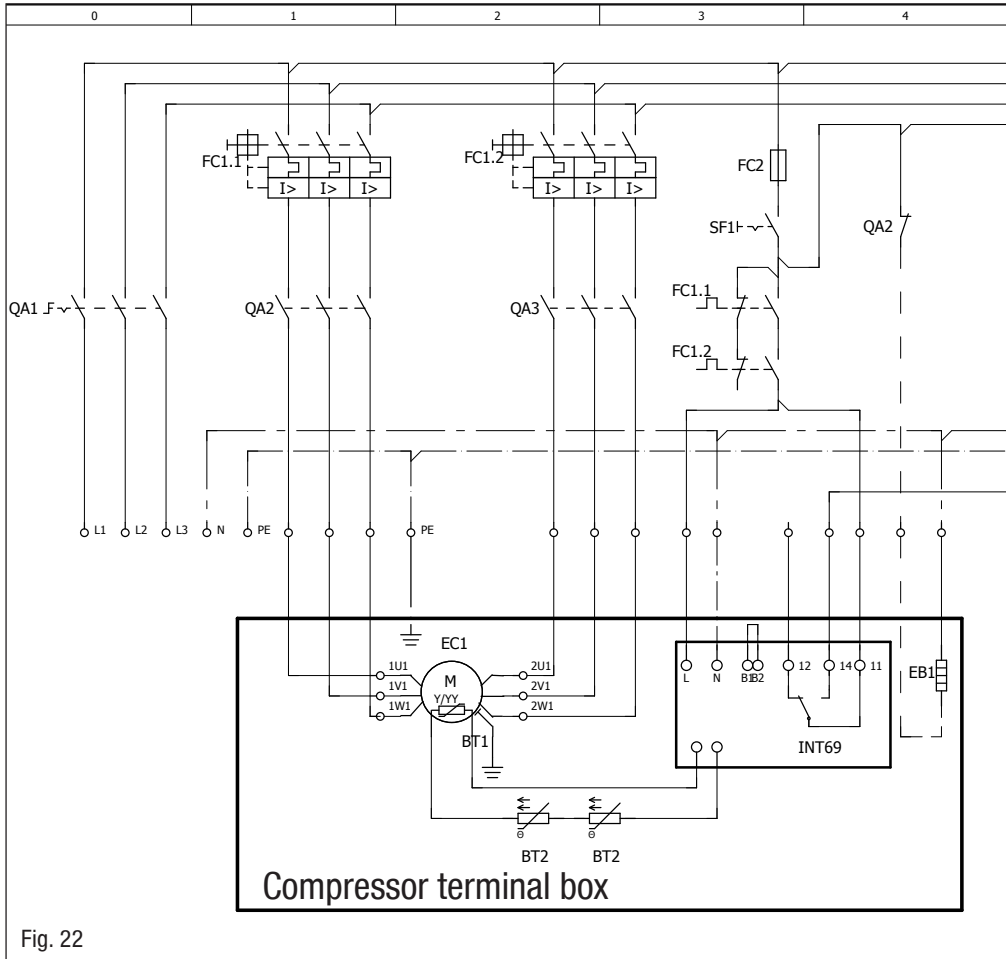
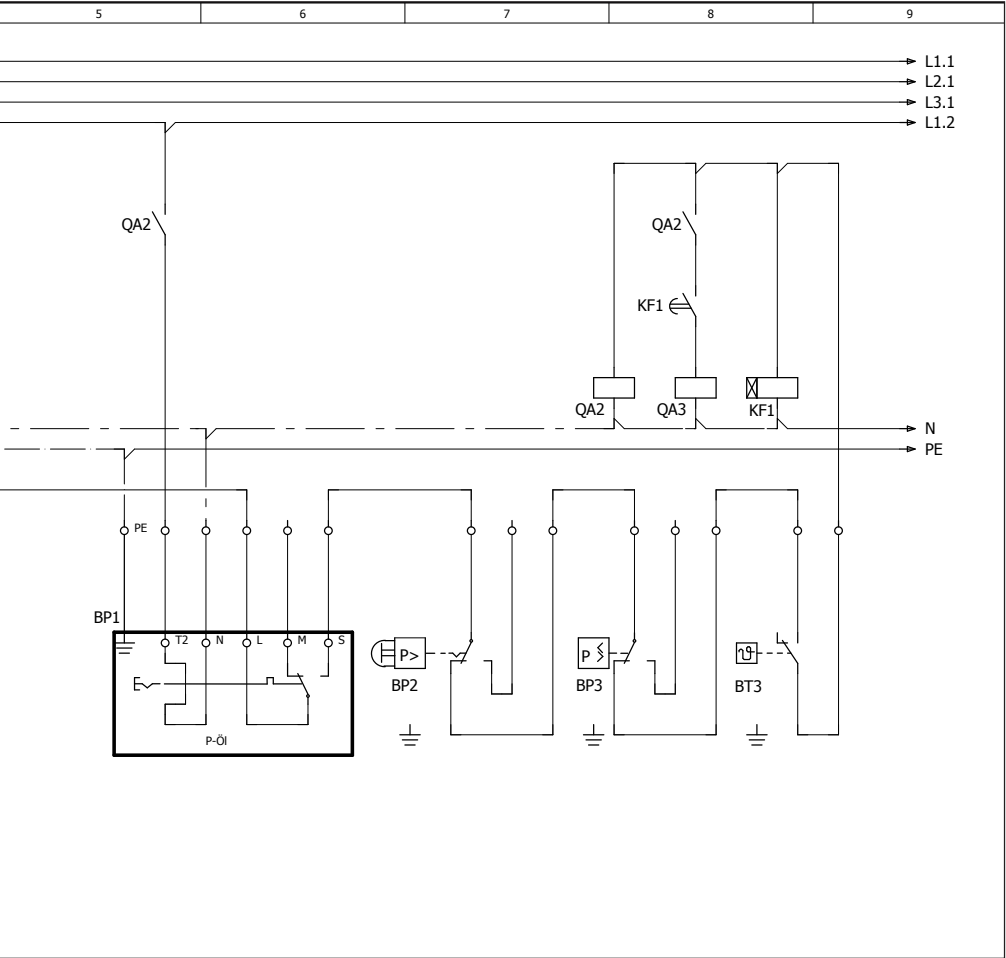

Fig. 22

BP1	Oil pressure safety switch
BP2	High pressure safety monitor
BP3	Safety chain (high/low pressure monitoring)
BT1	Cold conductor (PTC sensor) motor winding
BT2	Thermal protection thermostat*
BT3	Release switch (thermostat)
EB1	Oil sump heater
EC1	Compressor motor

* With several connect them in series



GB

FC1.1	Motor protection switch (part winding 1)
FC1.2	Motor protection switch (part winding 2)
FC2	Control power circuit fuse
KF1	Delay relay max. 1s
QA1	Main switch
QA2	Mains contactor (part winding 1)
QA3	Mains contactor (part winding 2)
SF1	Control voltage switch

5| Electrical connection

5.4 Electronic trigger unit INT69 G

The compressor motor is fitted with cold conductor temperature sensors (PTC) connected to the electronic trigger unit INT69 G in the terminal box. In case of excess temperature in the motor winding, the INT69 G deactivates the motor contactor. Once cooled, it can be restarted only if the electronic lock of the output relay (terminals B1 + B2) is released by interrupting the supply voltage.

The hot gas side of the compressor can also be protected against overtemperature using thermal protection thermostats (accessory).

The unit trips when an overload or inadmissible operating conditions occur. Find and remedy the cause.



INFO

The relay switching output is executed as a floating changeover contact. This electrical circuit operates according to the quiescent current principle, i.e. the relay drops into a the idle position and deactivates the motor contactor even in case of a sensor break or open circuit.

5.5 Connection of the trigger unit INT69 G



INFO

Connect the trigger unit INT69 G in accordance with the circuit diagram. Protect the trigger unit with a delayed-action fuse (FC2) of max. 4 A. In order to guarantee the protection function, install the trigger unit as the first element in the control power circuit.



ATTENTION

Measure circuit BT1 and BT2 (PTC sensor) must not come into contact with external voltage. This would destroy the trigger unit INT69 G and PTC sensors.

This would destroy the trigger unit INT69 G and PTC sensors.

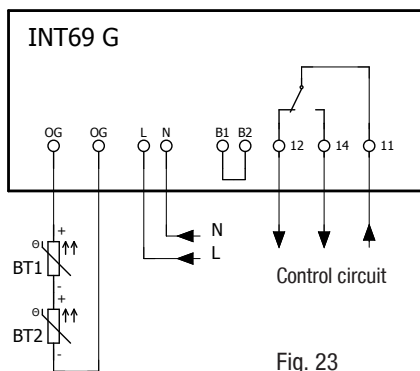

Fig. 23
Terminal box

5| Electrical connection

5.6 Function test of the trigger unit INT69 G

Before commissioning, after troubleshooting or making changes to the control power circuit, check the functionality of the trigger unit. Perform this check using a continuity tester or gauge.

	Gauge state	Relay position
1.	Deactivated state	11-12
2.	INT69 G switch-on	11-14
3.	Remove PTC connector	11-12
4.	Insert PTC connector	11-12
5.	Reset after mains on	11-14

Relay position INT69 G

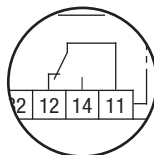

Fig. 24

5.7 Oil sump heater

In order to avoid damage to the compressor, the compressor is equipped with an oil sump heater as a standard feature.



ATTENTION The oil sump heater must generally be connected and operated!

Operation: The oil sump heater operates when the compressor is at a standstill. When the compressor starts up, the oil sump heating switches off.

Connexion: The oil sump heater must be connected via an auxiliary contact (or parallel wired auxiliary contact) of the compressor contactor to a separate electric circuit.

Electrical data: 230 V - 1 - 50/60 Hz, 160 W.

GB

6 | Commissioning

6.1 Preparations for start-up



INFO

In order to protect the compressor against inadmissible operating conditions, high-pressure and low-pressure pressostats controls are mandatory on the installation side.

The compressor has undergone trials in the factory and all functions have been tested. There are therefore no special running-in instructions.

Check the compressor for transport damage!



WARNING

When the compressor is not running, depending on ambient temperature and amount of refrigerant charge, it is possible that the pressure may rise and exceed permitted levels for the compressor. Adequate precautions must be taken to prevent this happening (e.g. using a cold storage medium, a receiver tank, a secondary refrigerant system, or pressure relief devices).

6.2 Pressure strength test

The compressor has been tested in the factory for pressure integrity. If however the entire system is to be subjected to a pressure integrity test, this should be carried out in accordance with EN 378-2 or a corresponding safety standard **without the inclusion of the compressor**.

GB

6.3 Leak test



DANGER

Risk of bursting!

The compressor must only be pressurised using nitrogen (N₂). Never pressurise with oxygen or other gases!

The maximum permissible overpressure of the compressor must not be exceeded at any time during the testing process (see name plate data)! Do not mix any refrigerant with the nitrogen as this could cause the ignition limit to shift into the critical range.

- Carry out the leak test on the refrigerating plant in accordance with EN 378-2 or a corresponding safety standard, while always observing the maximum permissible overpressure for the compressor.

6 | Commissioning

6.4 Evacuation



ATTENTION Do not start the compressor if it is under vacuum. Do not apply any voltage - even for test purposes (must only be operated with refrigerant).

Under vacuum, the spark-over and creepage current distances of the terminal board connection bolts shorten; this can result in winding and terminal board damage.

- First evacuate the **system** and then include **the compressor in the evacuation process**.
- Relieve the compressor pressure.
- Open the suction and pressure line shut-off valves.
- Turn on the oil sump heater.
- Evacuate the suction and discharge pressure sides using the vacuum pump.
- The vacuum has to be broken with nitrogen several times between the evacuation.
- At the end of the evacuation process, the vacuum should be < 1.5 mbar when the pump is switched off.
- Repeat this process as often as is required.

6.5 Refrigerant charge



CAUTION Wear personal protective clothing such as goggles and protective gloves!

GB

- Make sure that the suction and pressure line shut-off valves are open.



INFO Depending upon design of the CO₂ refrigerant filling bottle (with/without tubing) CO₂ can be filled in liquid after weight or gaseously.

Use only high-dried CO₂ quality (see chapter 3.1)!

- **Filling the liquid refrigerant:** It is recommended that the system first be filled at standstill with gas on the high-pressure side up to a system pressure of at least 5.2 bar (if it is filled below 5.2 bar with liquid, there is a risk of dry ice formation). Further filling according to system.
To eliminate the possibility of dry ice formation when the system is operating (during and after the filling process), the shut-off point of the low-pressure switch should be set to a value of at least 5.2 bar.



WARNING Never exceed the max. permissible pressures while charging. Precautions must be taken in time.

- A refrigerant supplement, which may become necessary after start-up, can be topped up in vapour form on the suction side.



ATTENTION

- Avoid overfilling the machine with refrigerant!
- Do not charge liquid refrigerant into the suction-side on the compressor.
- Do not mix additives with the oil and refrigerant.

6 | Commissioning

6.6 Start-up



WARNING Ensure that both shut-off valves are open before starting the compressor!

- Check that the safety and protection devices (pressure switch, motor protection, electrical contact protection measures, etc.) are functioning properly.
- Switch on the compressor and let it run for at least 10 minutes.
- The machine should reach a state of equilibrium.
- Check the **oil level**: The oil level must be visible in the sight glass.
- After a compressor is replaced, the oil level must be checked again. If the level is too high, oil must be drained off (danger of oil liquid shocks; reduced capacity of the refrigerating system).



ATTENTION If larger quantities of oil have to be topped up, there is a risk of oil impact effects. If this is the case, check the oil return!

6.7 Pressure switch

Suitably adjusted pressure switches that switch off the compressor **before reaching** the maximum permissible operating pressure must be installed in the system. The pressure reduction for the pressure switches can occur either at the suction and pressure lines between the shut-off valve and compressor or at the non-lockable connections for the shut-off valves (connections A and B, see Chapter 9).

6 | Commissioning

6.8 Decompression valves



ATTENTION The compressor is fitted with two decompression valves. One valve each on the suction and discharge side. If excessive pressures are reached, the valves open and prevent further pressure increase.

Thereby CO₂ is blown off to the ambient!

In the event that a pressure relief valve activates repeatedly, check valve and replace if necessary as during blow-off extreme conditions can occur, which may result in a permanent leak. Always check system for refrigerant loss after activation of pressure relief valve!

The decompression valves do not replace any pressure switches and the additional safety valves in the system. Pressure switches must always be installed in the system and designed or adjusted in accordance with EN 378-2 or appropriate safety standards.

Failure to observe can result in risk of injury from CO₂ streaming out of the two decompression valves!

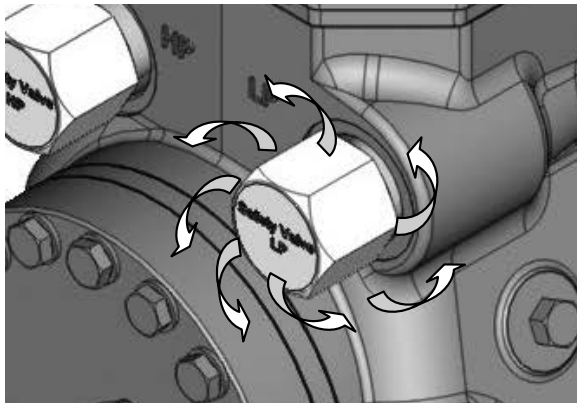

CO₂ streaming out

Fig. 25

GB

7 | Maintenance

6.9 Avoid slugging



ATTENTION Slugging can result in damage to the compressor and cause refrigerant to leak.

To prevent slugging:

- The complete refrigeration plant must be properly designed.
- All components must be compatibly rated with each other with regard to output (particularly the evaporator and expansion valves).
- Suction gas superheating at the compressor input **should be > 10 K** (check the setting of the expansion valve).
- Regard oil temperature and pressure gas temperature. (The pressure gas temperature has to be high enough min. 50 °C, so the oil temperature is > 30 °C).
- The system must reach a state of equilibrium.
- Particularly in critical systems (e.g. several evaporator points), measures such as the use of liquid traps, solenoid valve in the liquid line, etc. are recommended.

There should be no movement of refrigerant in the compressor while the system is at a standstill.

6.10 Filter dryer

GB

Gaseous CO₂ has a significantly lower solubility in water than other refrigerants. At low temperatures it can therefore cause blocking of valves and filters due to ice or hydrate. For this reason we recommend the use of an adequately sized filter drier and a sight glass with a moisture indicator.

7 | Maintenance

7.1 Preparation



WARNING Before starting any work on the compressor:

- Switch off the compressor and secure it to prevent a restart.
- Relieve compressor of system pressure.
- Prevent air from infiltrating the system!

After maintenance has been performed:

- Connect safety switch.
- Evacuate compressor.
- Release switch-on lock.



WARNING The decompression has to be carried out in a way that no dry ice respectively solid CO₂ is produced which blocks the outlet and could hinder the streaming out of CO₂. Otherwise, there is the danger that pressure can be built up again.

7 | Maintenance

7.2 Work to be carried out

In order to guarantee optimum operational reliability and service life of the compressor, **we recommend** carrying out servicing and inspection work at regular intervals:

- **Oil change:**

- not mandatory for factory-produced series systems.
- for field installations or when operating near the application limit: for the first time after 100 to 200 operating hours, then approx. every 3 years or 10,000 - 12,000 operating hours. Dispose of used oil according to the regulations; observe national regulations.

- **Annual checks:** Oil level, leak tightness, running noises, pressures, temperatures, function of auxiliary devices such as oil sump heater, pressure switch.

7.3 Spare part recommendation/accessories

Available spare parts and accessories can be found on our compressor selection tool under **vap.bock.de** as well as at **bockshop.bock.de**.

Only use genuine Bock spare parts!

7.4 Lubricants

For operation with CO₂ the Bock oil C 85 E is necessary!

GB

7.5 Decommissioning

Close the shut-off valves on the compressor. CO₂ does not need to be recycled and can therefore be blown off into the environment. It is essential to ensure good ventilation or conduct the CO₂ into the outdoors to avoid danger of suffocation. When releasing CO₂, avoid a fast drop in pressure to prevent oil from exiting with it. If the compressor is unpressurized, remove the piping on the pressure- and suction-side (e.g. dismantling of the shut-off valve, etc.) and remove the compressor using an appropriate hoist. Dispose of the oil inside in accordance with the applicable national regulations.

When decommissioning the compressor (eg. for service or replacement of the compressor) larger amounts of CO₂ in the oil can be set free. If the decompression of the compressor is not sufficient enough, closed shut-off valves may lead to intolerable excessive pressure. For this reason the suction side (LP) and the high pressure side (HP) of the compressor have to be secured by decompression valves.

8 | Technical data

Type	No. of cylinders		Displacement (1450 / 1740 rpm)		Voltage	Max. operating current ②		Max. power consumption ②	Starting current (rotor locked)		Weight	Connections ④		Oil charge (sight glass centre)
	HGX2/70-4 CO ₂ T	HGX2/90-4 CO ₂ T	50 / 60 Hz	m ³ /h		PW 1+2	A		PW 1 / PW 1+2	A		Discharge line DV	mm (inch)	
				6.20 / 7.40	① V 380-420 V Y/YY - 3 - 50 Hz PW 440-480 V Y/YY - 3 - 60 Hz PW PW = Part Winding Winding ratio : 50 % / 50 %	18,3	10,9	65 / 109	145	18 (-)	22 (7/8)	2.6		
		2	7.70 / 9.30	23.8		13.9	87 / 149	160				2.3		

① Tolerance (± 10%) relative to the mean value of the voltage range.
Other voltages and types of current on request.

② - The specifications for max. power consumption apply for 50Hz operation.
For 60Hz operation, the specifications have to be multiplied by the factor 1.2. The max. working current remains unchanged.

- Take account of the max. operating current / max. power consumption for design of fuses, supply lines and safety devices. Fuse: Consumption category AC3

③ All specifications are based on the average of the voltage range
④ Compression joint for steel pipes

9 | Dimensions and connections

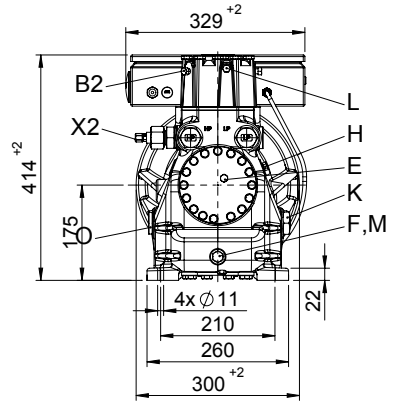
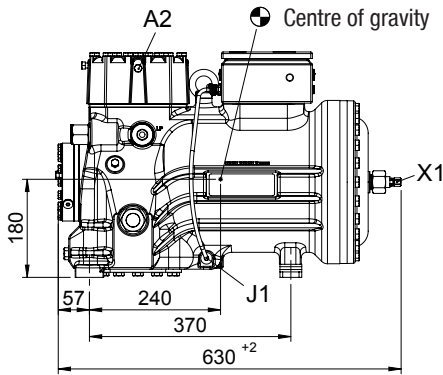

Dimensions and connections with shut-off valves

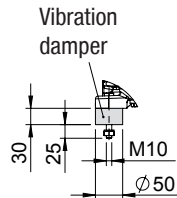
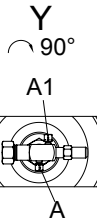
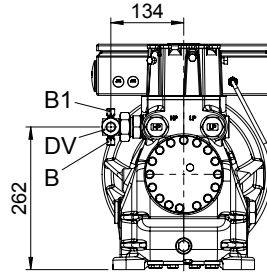
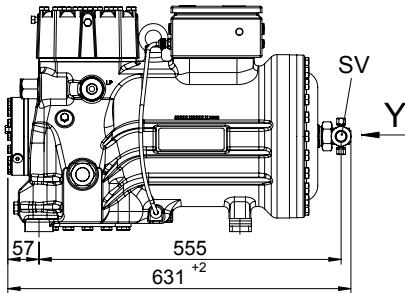

Dimensions in mm
Fig. 26

9 | Dimensions and connections

SV	Suction line	see technical data, Chapter 8	
DV	Discharge line		
A	Connection suction side, not lockable		7/16" UNF
A1	Connection suction side, lockable		7/16" UNF
A2	Connection suction side, not lockable		1/8" NPTF
B	Connection discharge side, not lockable		7/16" UNF
B1	Connection discharge side, lockable		7/16" UNF
B2	Connection discharge side, not lockable		1/8" NPTF
E	Connection oil pressure gauge		7/16" UNF
F	Oil drain		M22 x 1.5
H	Oil charge plug		1/8" NPTF
J1	Oil sump heater		Ø 15 mm
K	Sight glass		G 1"
L*	Connection thermal protection thermostat		1/8" NPTF
M	Oil filter		M22 x 1.5
O	Connection oil level regulator		G 1"
X1	Connection for schrader valve, suction side		7/16" UNF
X2	Connection for schrader valve, discharge side		7/16" UNF

* No connection discharge side

10| Declaration of incorporation

Declaration of incorporation for incomplete machinery in accordance with EC Machinery Directive 2006/42/EC, Annex II 1. B

Manufacturer: Bock GmbH
Benzstraße 7
72636 Frickenhausen, Germany

We, as manufacturer, declare in sole responsibility that the incomplete machinery

Name: Semi-hermetic compressor
Types: HG(X)12P/60-4 S (HC) HG(X)88e/3235-4(S) (HC)
HGX12P/60 S 0,7 LG HGX88e/3235 (ML/S) 95 LG
HG(X)22(P)(e)/125-4 A HG(X)34(P)(e)/380-4 (S) A
HGX34(P)(e)/255-2 (A) HGX34(P)(e)/380-2 (A)(K)
HA(X)12P/60-4 HA(X)6/1410-4
HAX22e/125 LT 2 LG HAX44e/665 LT 14 LG
HGX12e/20-4 (ML/S) CO₂ (LT) ... HGX44e/665-4 (ML/S) CO₂ (LT)
HGX2/70-4 CO₂T HGX46/440-4 (ML/S/SH) CO₂ T
HGZ(X)7/1620-4 HGZ(X)7/2110-4

Name: Open type compressor
Types: AM(X)2/58-4 AM(X)5/847-4
F(X)2 F(X)88/3235 (NH3)
FK(X)1 FK(X)3
FK(X)20/120 (K/N/TK)..... FK(X)50/980 (K/N/TK)

Serial number: BC00000A001 – BH99999Z999

complies with the following provisions of the above-mentioned Directive:

According to Annex I, points 1.1.2, 1.1.3, 1.1.5, 1.3.2, 1.3.3, 1.3.7, 1.5.1, 1.5.2, 1.5.13 and 1.7.1 to 1.7.4 (excepted 1.7.4 f) are fulfilled.

Applied harmonised standards, in particular:

EN ISO 12100 :2010 Safety of machinery — General principles for design — Risk assessment and risk reduction
EN 12693 :2008 Refrigerating systems and heat pumps — Safety and environmental requirements — Positive displacement refrigerant compressors

Remarks: We also declare that the special technical documentation for this incomplete machine has been created in accordance with Annex VII, Part B and we obligate to provide these upon reasoned request from the individual national authorities by data transfer.

Commissioning is prohibited until it has been confirmed that the machinery into which the incomplete machine above is to be incorporated complies with the EC Machinery Directive and an EC Declaration of Conformity, Annex II. 1. A exists.

Authorized person for compiling and handing
over technical documentation:

Bock GmbH
Alexander Layh
Benzstraße 7
72636 Frickenhausen, Germany

Frickenhausen, 04th of January 2021



i. A. Alexander Layh, Technical director

GB

11| Service

Dear customer,

if you have any questions about installation, operation and accessories, please contact our technical service or specialist wholesaler and/or our representative. The Bock service team can be contacted by phone, **+49 (0)7022 9454-0** or via **service@bock.de**

Yours faithfully Bock GmbH



BOCK[®]

Bock GmbH

Benzstraße 7

72636 Frickenhausen

Germany

Phone +49 7022 9454-0

Fax +49 7022 9454-137

www.bock.de