

BOCK HGX22e S CO₂/HGX34e S CO₂

Assembly instructions

g6422-06.2021-Gb

Translation of the original instructions

HGX22e/85-4 S CO₂
HGX22e/105-4 S CO₂
HGX22e/130-4 S CO₂

HGX34e/145-4 S CO₂
HGX34e/170-4 S CO₂
HGX34e/210-4 S CO₂
HGX34e/255-4 S CO₂

BOCK[®]

colour the world
of tomorrow

About these instructions

Read these instructions before assembly and before using the compressor. This will avoid misunderstandings and prevent damage. Improper assembly and use of the compressor can result in serious or fatal injury.

Observe the safety instructions contained in these instructions.

These instructions must be passed onto the end customer along with the unit in which the compressor is installed.

Manufacturer

Bock GmbH
72636 Frickenhausen

Contact

Bock GmbH
Benzstraße 7
72636 Frickenhausen
Germany

GB

Phone +49 7022 9454-0

Fax +49 7022 9454-137

www.bock.de

service@bock.de

1	Safety	4
1.1	Identification of safety instructions	
1.2	Qualifications required of personnel	
1.3	General safety instructions	
1.4	Intended use	
2	Product description	6
2.1	Short description	
2.2	Name plate	
2.3	Type key	
3	Areas of application	8
3.1	Refrigerants	
3.2	Oil charge	
3.3	Limits of application	
4	Compressor assembly	9
4.1	Storage and transport	
4.2	Setting up	
4.3	Pipe connections	
4.4	Pipes	
4.5	Laying suction and pressure lines	
4.6	Operating the shut-off valves	
4.7	Operating mode of the lockable service connections	
4.8	Suction pipe filter	
5	Electrical connection	12
5.1	Information for contactor and motor contactor selection	
5.2	Connection of the driving motor	
5.3	Circuit diagram for direct start 230 V Δ / 400 V Y	
5.4	Electronic trigger unit INT69 G	
5.5	Connection of the electronic trigger unit INT69 G	
5.6	Functional test of the electronic trigger unit INT69 G	
5.7	Oil sump heater (accessories)	
6	Commissioning	18
6.1	Preparations for start-up	
6.2	Pressure strength test	
6.3	Leak test	
6.4	Evacuation	
6.5	Refrigerant charge	
6.6	Start-up	
6.7	Decompression valves	
6.8	Avoiding slugging	
6.9	Filter dryer	
6.10	Connection of oil level regulator	
7	Maintenance	22
7.1	Preparation	
7.2	Work to be carried out	
7.3	Spare parts recommendation/accessories	
7.4	Lubricants / oil	
7.5	Decommissioning	
8	Technical data	24
9	Dimensions and connections	26
10	Declaration of installation	28
11	Service	29

1 | Safety

1.1 Identification of safety instructions:



DANGER

Indicates a dangerous situation which, if not avoided, will cause immediate fatal or serious injury



WARNING

Indicates a dangerous situation which, if not avoided, may cause fatal or serious injury



CAUTION

Indicates a dangerous situation which, if not avoided, may immediately cause fairly severe or minor injury.



ATTENTION

Indicates a situation which, if not avoided, may cause property damage



INFO

Important information or tips on simplifying work

GB

1.2 Qualifications required of personnel



WARNING

Inadequately qualified personnel poses the risk of accidents, the consequence being serious or fatal injury. Work on compressors must therefore only be performed by personnel with the qualifications listed below:

- For example, a refrigeration technician, refrigeration mechatronics engineer. As well as professions with comparable training, which enable personnel to assemble, install, maintain and repair refrigeration and air-conditioning systems. Personnel must be capable of assessing the work to be carried out and recognising any potential dangers.

1 | Safety

1.3 Safety instructions



WARNING

Risk of accidents.

Refrigerating compressors are pressurised machines and as such call for heightened caution and care in handling.

The maximum permissible overpressure must not be exceeded, even for testing purposes.

Risk of burns!

- Depending on the operating conditions, surface temperatures of over 60°C on the discharge side or below 0°C on the suction side can be reached.

- Avoid contact with refrigerant necessarily.

Contact with refrigerant can cause severe burns and skin damage.

Danger of suffocation.

CO₂ is a non-flammable, acidic, colorless and odorless gas and heavier than air.

Never release significant volumes of CO₂ or the entire contents of the system into closed rooms!

Safety installations are designed or adjusted in accordance with EN 378-2 or appropriate safety standards.

GB

1.4 Intended use



WARNING

The compressor may not be used in potentially explosive environments!

These assembly instructions describe the standard version of the compressor named in the title manufactured by Bock. Bock refrigerating compressors are intended for installation in a machine (within the EU according to the EU Directives 2006/42/EC Machinery Directive, 2014/68/EU Pressure Equipment Directive).

Commissioning is permissible only if the compressor has been installed in accordance with these assembly instructions and the entire system into which it is integrated has been inspected and approved in accordance with legal regulations.

The compressor is intended for use with CO₂ in sub-critical systems in compliance with the limits of application.

Only the refrigerant specified in these instructions may be used.

Any other use of the compressor is prohibited!

2 | Product description

2.1 Short description

- **HGX22e S CO₂**: Semi-hermetic two-cylinder reciprocating compressor with suction gas cooled drive motor.
- **HGX34e S CO₂**: Semi-hermetic four-cylinder reciprocating compressor with suction gas cooled drive motor.
- The flow of refrigerant sucked in from the evaporator is led over the engine and provides for a particularly intensive cooling. Thus the engine can be kept special during high load on a relatively low temperature level.
- Oil pump independent of direction of rotation for reliable and safe oil supply
- One pressure relief valve each on the low and high pressure side, which vent into the atmosphere when these inadmissibly high printing pressures are reached.

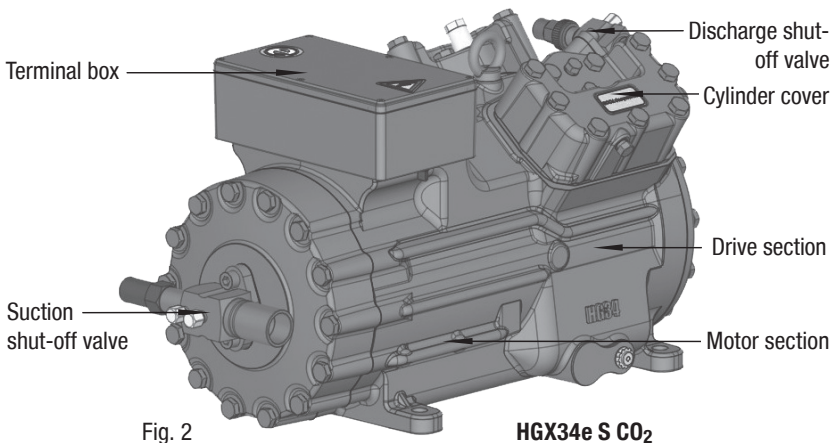
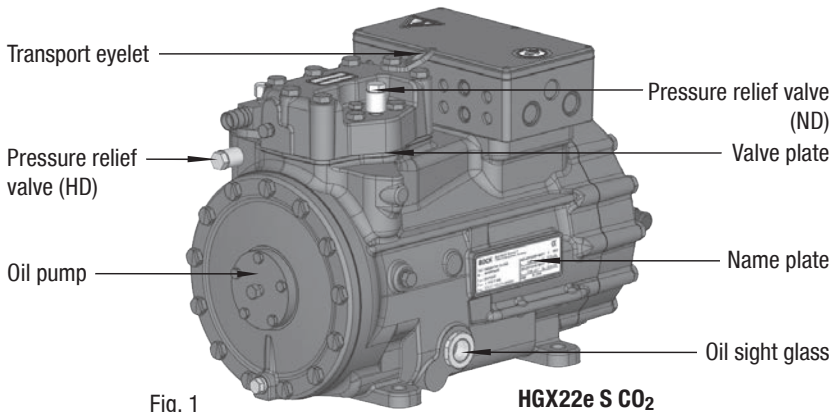

Dimension and connection values can be found in Chapter 9

2 | Product description

2.2 Name plate (example)

BOCK		Bock GmbH, Benzstr. 7 72636 Frickenhausen, Germany	CE
1	Typ : HGX34e/255-4 S CO ₂	220-240V Δ / 380-420VY -3- 50HZ	6
2	Nr. : AX34567A045	n : 1450 min ⁻¹ V _{th} : 22,3 m ³ /h	7
3	I _{max} : 44,8/25,9A	265-290V Δ / 440-480VY -3- 60HZ	8
4	I _{block} Δ: 178A Y: 103A	n : 1740 min ⁻¹ V _{th} : 26,8 m ³ /h	9
5	p _{max} : ND(LP) / HD(HP) = 40/55 bar	IP66	10
		Öl : BOCKlub E85	11
			12
			13

Fig. 3

1	Type designation	6	Voltage, circuit, frequency	} 50 Hz
2	Machine number	7	Nominal rotation speed	
3	maximum operating current	8	Displacement	} 60 Hz
4	Starting current (rotor blocked)	9	Voltage, circuit, frequency	
5	ND (LP): max. permissible operating pressure (g) Low pressure side	10	Nominal rotation speed	
	HD (HP): max. permissible operating pressure (g) High pressure side	11	Displacement	
		12	Oil type filled at the factory	
		13	Terminal box protection type	

i Observe the limits of application diagrams!

i Electrical accessories can change the IP protection class!

GB

2.3 Type key (example)

HG X 34 e / 255- 4 S CO₂

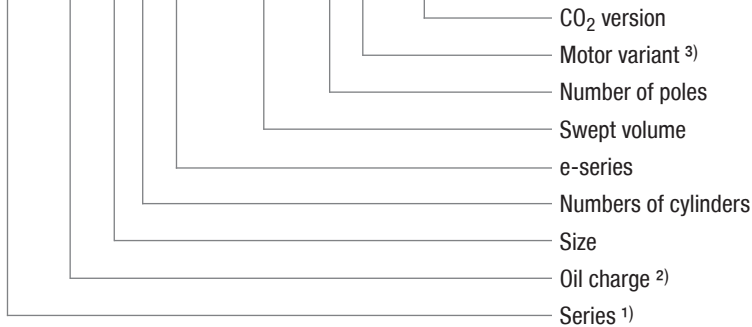

- 1) HG - Hermetic Gas-Cooled (suction gas-cooled)
- 2) X - Ester oil charge
- 3) S - More powerful motor

3 | Areas of application

3.1 Refrigerants

- CO₂: R744 (Recommendation CO2 quality 4.5 (< 5 ppm H₂O))

3.2 Oil charge

- The compressors are filled at the factory with the following oil type:
BOCK lub E85 (only this oils may be used)



ATTENTION Property damage possible.

The oil level must be in the visible part of the sight glass; damage to the compressor is possible if overfilled or underfilled!

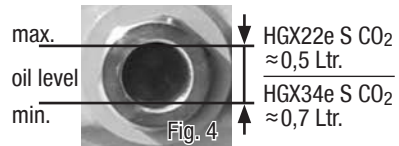

3.3 Limits of application



ATTENTION Compressor operation is possible within the operating limits. These can be found in Bock compressor selection tool (VAP) under vap.bock.de. Observe the information given there.

- Permissible ambient temperature (-20°C) - (+60°C).
- Max. permissible discharge end temperature 160°C.
- Min. oil temperature ≥ 30°C.
- Min. pressure gas temperature ≥ 50°C.
- Max. permissible switching frequency 8x /h.
- A minimum running time of 3 min. steady-state condition (continuous operation) must be achieved.

For operation with frequency converter:

- Frequency range 25-70 Hz
- The maximum current and power consumption must not be exceeded. In the case of operation above the mains frequency, the application limit can therefore be limited.

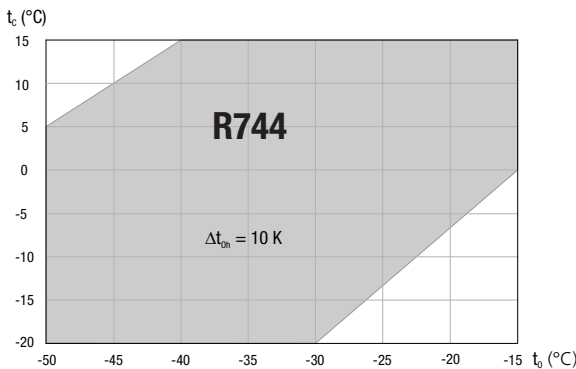

Unlimited application range

t_o Evaporation temperature (°C)

t_c Condensing temperature (°C)

Δt_{oh} Suction gas superheat (K)

t_{oh} Suction gas temperature (°C)

Max. permissible operating pressure (LP/HP)¹⁾: 40/55 bar

¹⁾ LP = Low pressure

HP = High pressure

Fig. 5

4| Compressor assembly



INFO

New compressors are factory-filled with inert gas. Leave this service charge in the compressor for as long as possible and prevent the ingress of air. Check the compressor for transport damage before starting any work.

4.1 Storage and transportation



- Storage at (-30°C) - (+70°C), maximum permissible relative humidity 10% -95 %, no condensation.
- Do not store in a corrosive, dusty, vaporous atmosphere or in a combustible environment.



- Use transport eyelet.
- Do not lift manually!
- Use lifting gear!

4.2 Setting up



ATTENTION

Attachments (e.g. pipe holders, additional units, fastening parts, etc.) directly to the compressor are not permissible!

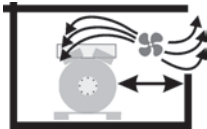

- Provide adequate clearance for maintenance work.
- Ensure adequate compressor ventilation.



- Do not use in a corrosive, dusty, damp atmosphere or a combustible environment.

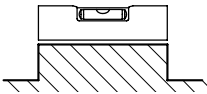

- Setup on an even surface or frame with sufficient load-bearing capacity. Only erect on a slant in consultation with the manufacturer.
- Single compressor preferably on vibration damper.
- Duplex and parallel circuits always rigid.



- Sun protection: If the compressor is set up outdoors, it has to be protected from direct sunlight.

GB

4.3 Pipe connections



ATTENTION

Damage possible.
Superheating can damage the valve.
Remove the pipe supports therefore from the valve for soldering and accordingly cool the valve body during and after soldering. Only solder using inert gas to inhibit oxidation products (scale).

4| Compressor assembly

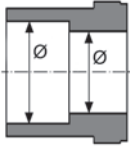

Fig. 6: graduated internal diameter

- The **pipe connections** have graduated inside diameters so that pipes with standart millimetre and inch dimensions can be used.
- The connection diameters of the shut-off valves are rated for maximum compressor output. **The actual required pipe cross section must be matched to the output. The same applies for non-return valves.**

4.4 Pipes

- Pipes and system components must be clean and dry inside and free of scale, swarf and layers of rust and phosphate. Only use air-tight parts.
- Lay pipes correctly. Suitable vibration compensators must be provided to prevent pipes being cracked and broken by severe vibrations.
- Ensure a proper oil return.
- Keep pressure losses to an absolute minimum.

GB

4.5 Laying suction and pressure lines



ATTENTION Property damage possible.

Improperly installed pipes can cause cracks and tears, the result being a loss of refrigerant.



INFO

Proper layout of the suction and discharge lines directly after the compressor is integral to the system's smooth running and vibration behaviour.

A rule of thumb: Always lay the first pipe section starting from the shut-off valve **downwards and parallel to the drive shaft.**

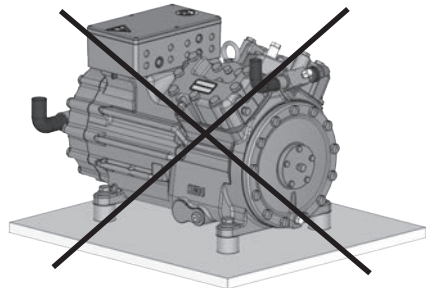
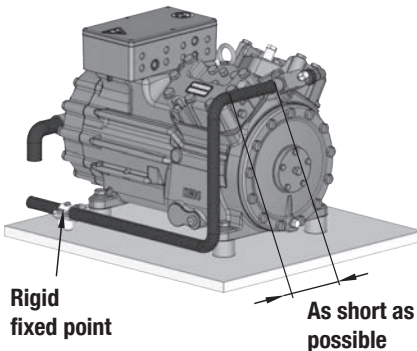

Fig. 7

4 | Compressor assembly

4.6 Operating the shut-off valves

- Before opening or closing the shut-off valve, release the valve spindle seal by approx. $\frac{1}{4}$ of a turn counter-clockwise.
- After activating the shut-off valve, re-tighten the adjustable valve spindle seal clockwise.

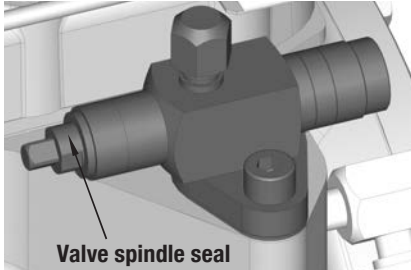

Fig. 8

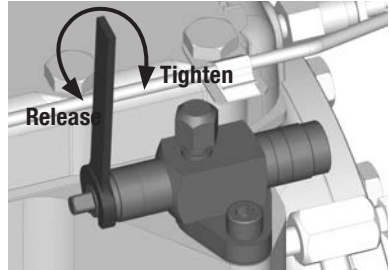
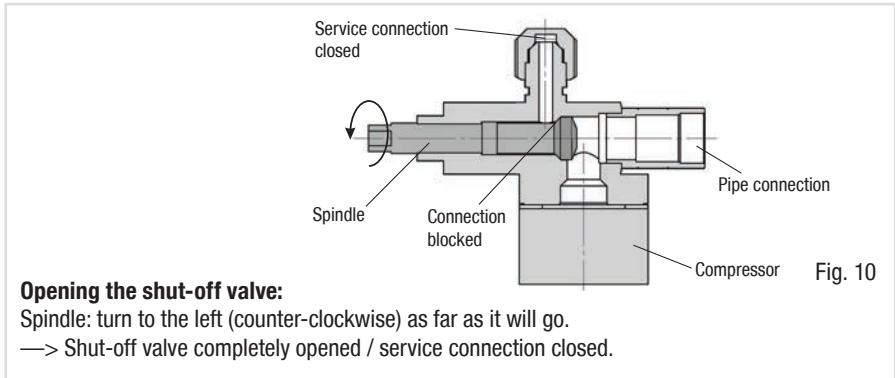
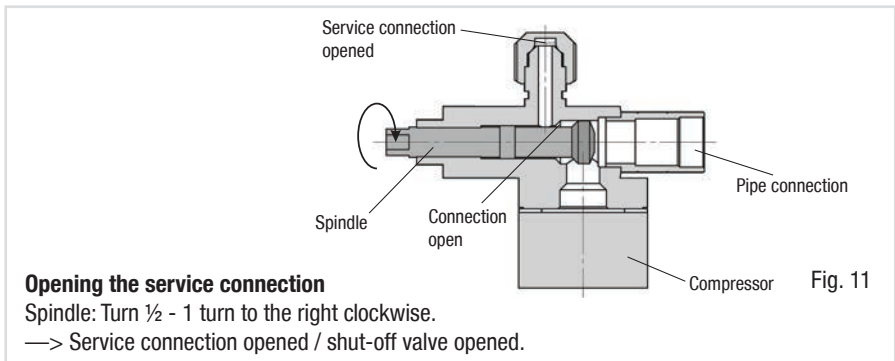

Fig. 9

4.7 Operating mode of the lockable service connections



GB



After activating the spindle, generally fit the spindle protection cap again and tighten with 14-16 Nm. This serves as a second sealing feature during operation.

4| Compressor assembly

4.8 Suction pipe filter

For systems with long pipes and higher degree of contamination, a filter on the suction-side is recommended. The filter has to be renewed depending on the degree of contamination (reduced pressure loss).

5| Electrical connection

5 Electrical connection



DANGER

Risk of electric shock! High voltage!

Only carry out work when the electrical system is disconnected from the power supply!



ATTENTION

When attaching accessories with an electrical cable, a minimum bending radius of 3 x the cable diameter must be maintained for laying the cable.



INFO

Connect the compressor motor in accordance with the circuit diagram (see inside of terminal box).

- Use suitable cable entry point of the correct protection type (see name plate) for routing cables into the terminal box. Insert the strain reliefs and prevent chafe marks on the cables.
- Compare the voltage and frequency values with the data for the mains power supply.

Only connect the motor if these values are the same.

5.1 Information for contactor and motor contactor selection

All protection equipment, switching and monitoring devices must comply with the local safety regulations and established specifications (e.g. VDE) as well as the manufacturer's specifications. **Motor protection switches are required!** Motor contactors, feed lines, fuses and motor protection switches must be rated according to the maximum operating current (see name plate). For motor protection, use a current-independent, time-delayed overload protection device for monitoring all three phases. Adjust the overload protection device so that it must be actuated within 2 hours at 1.2 times the maximum working current.

5 | Electrical connection

5.2 Connection of the driving motor

The compressor is designed with a motor for star-delta circuits.

Designation on the name plate
Δ / Y

Star-delta start-up is only possible on 230 V voltage supply. Example:

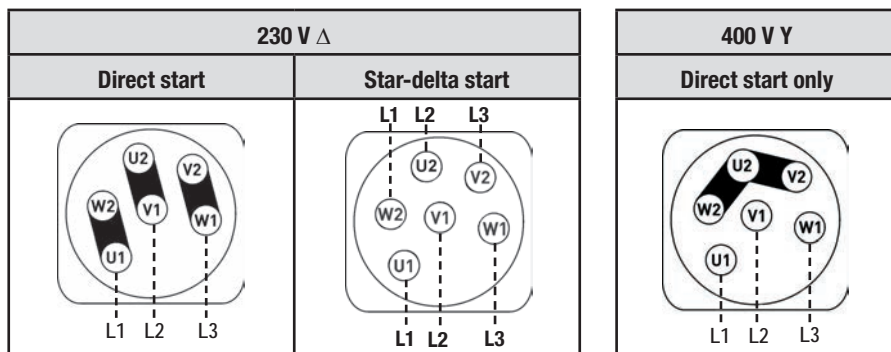

GB



INFO

The connection examples shown refer to the standard version. In the case of special voltages, the instructions affixed to the terminal box apply.

5.3 Circuit diagramm for direct start 230 V Δ / 400 V Y

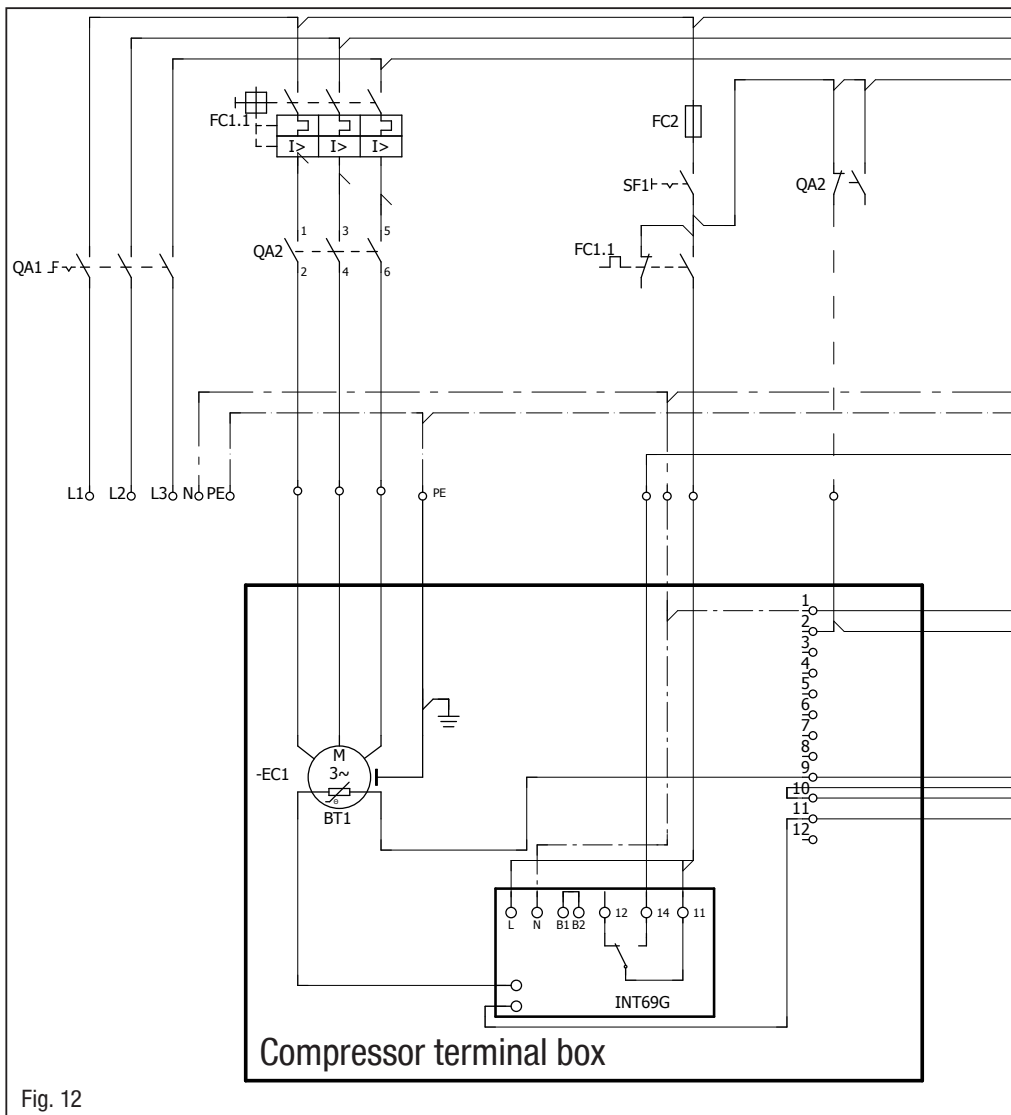
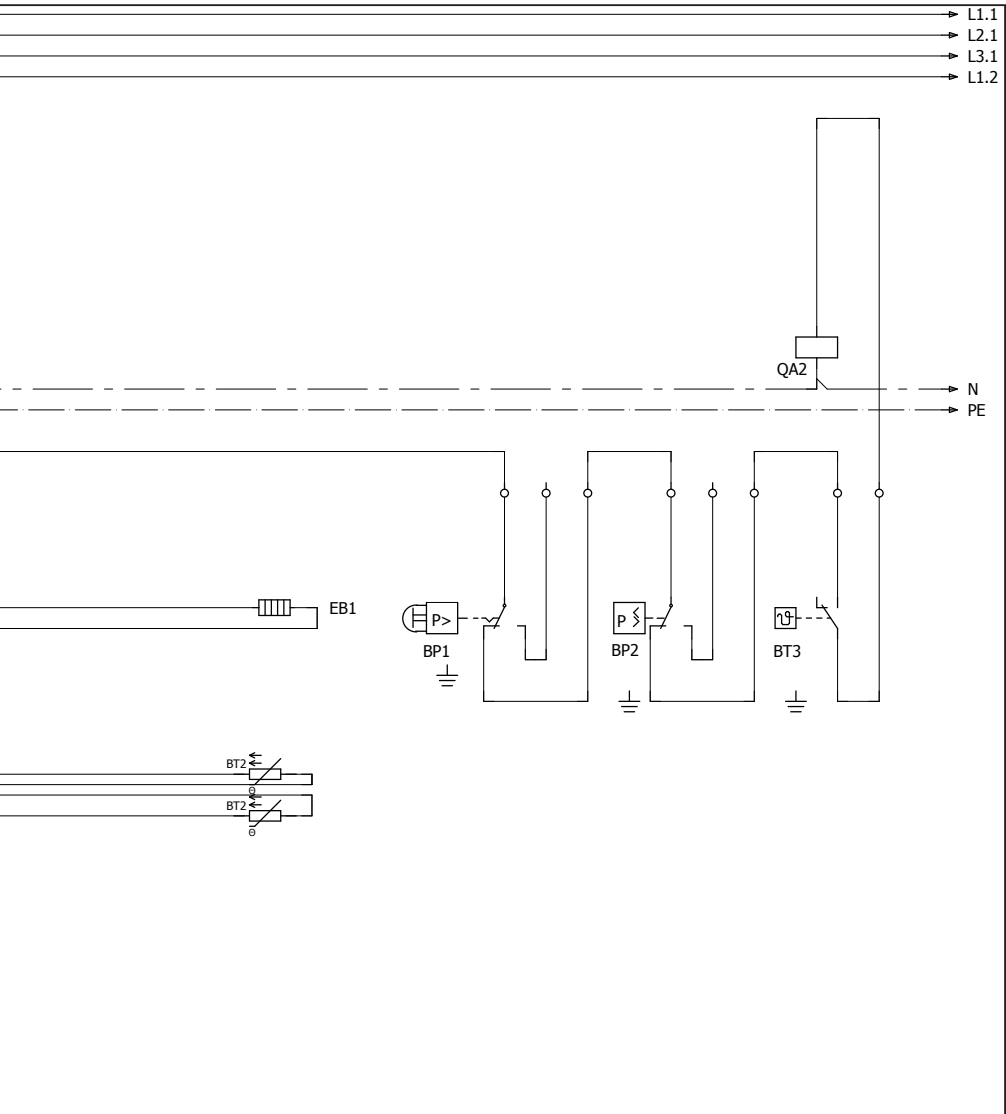

Fig. 12

BP2	High pressure safety controller
BP3	Safety chain (high/low pressure monitoring)
BT2	Thermal protection thermostat (PTC sensor)
BT3	Release switch (thermostat/pressostat)
EB1	Oil sump heater
EC1	Compressor motor



GB

FC1.1	Motor protection switch
FC2	Control power circuit fuse
INT69 G	Electronic trigger unit INT69 G
QA1	Main switch
QA2	Mains contactor
SF1	Control voltage switch

5| Electrical connection

5.4 Electronic trigger unit INT69 G

The compressor motor is fitted with cold conductor temperature sensors (PTC) connected to the electronic trigger unit INT69 G in the terminal box. In case of excess temperature in the motor winding, the INT69 G deactivates the motor contactor. Once cooled, it can be restarted only if the electronic lock of the output relay (terminals B1+B2) is released by interrupting the supply voltage.

The hot gas side of the compressor can also be protected against overtemperature using thermal protection thermostats (accessory).

The unit trips when an overload or inadmissible operating conditions occur. Find and remedy the cause.



INFO

The relay switching output is executed as a floating changeover contact. This electrical circuit operates according to the quiescent current principle, i.e. the relay drops into a the idle position and deactivates the motor contactor even in case of a sensor break or open circuit.

5.5 Connection of the trigger unit INT69 G



INFO

Connect the trigger unit INT69 G in accordance with the circuit diagram. Protect the trigger unit with a delayed-action fuse (FC2) of max. 4 A. In order to guarantee the protection function, install the trigger unit as the first element in the control power circuit.



ATTENTION

Measure circuit BT1 and BT2 (PTC sensor) must not come into contact with external voltage. This would destroy the trigger unit INT69 G and PTC sensors.

This would destroy the trigger unit INT69 G and PTC sensors.

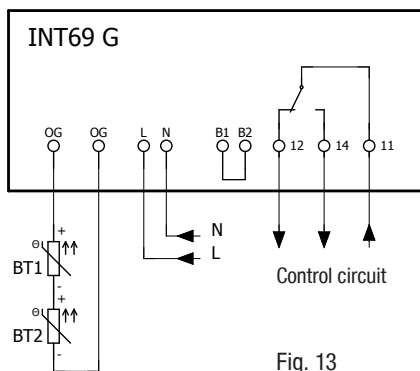

Fig. 13
Terminal box

5| Electrical connection

5.6 Function test of the trigger unit INT69 G

Before commissioning, after troubleshooting or making changes to the control power circuit, check the functionality of the trigger unit. Perform this check using a continuity tester or gauge.

	Gauge state	Relay position
1.	Deactivated state	11-12
2.	INT69 G switch-on	11-14
3.	Remove PTC connector	11-12
4.	Insert PTC connector	11-12
5.	Reset after mains on	11-14

Relay position INT69 G

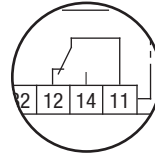

Fig. 14

5.7 Oil sump heater (accessories)

In order to avoid damage to the compressor, the compressor must be equipped with an oil sump heater.



ATTENTION The oil sump heater must generally be connected and operated!

Connexion: The oil sump heater must be connected via an auxiliary contact (or parallel wired auxiliary contact) of the compressor contactor to a separate electric circuit.

Electrical data: 110 - 240 V - 1 - 50/60 Hz, 50 - 120 W, PTC-heater adjusting.

GB

6| Commissioning

6.1 Preparations for start-up



INFO

To protect the compressor against inadmissible operating conditions, high pressure and low pressure pressostats are mandatory on the installation side.

The compressor has undergone trials in the factory and all functions have been tested. There are therefore no special running-in instructions.

Check the compressor for transport damage!



WARNING

When the compressor is not running, depending on ambient temperature and amount of refrigerant charge, it is possible that the pressure may rise and exceed permitted levels for the compressor. Adequate precautions must be taken to prevent this happening (e.g. using a cold storage medium, a receiver tank, a secondary refrigerant system, or pressure relief devices).

6.2 Pressure strength test

GB

The compressor has been tested in the factory for pressure integrity. If however the entire system is to be subjected to a pressure integrity test, this should be carried out in accordance with EN 378-2 or a corresponding safety standard **without the inclusion of the compressor**.

6.3 Leak test



DANGER

Risk of bursting!

The compressor must only be pressurised using nitrogen (N₂). Never pressurise with oxygen or other gases!

The maximum permissible overpressure of the compressor must not be exceeded at any time during the testing process (see name plate data)! Do not mix any refrigerant with the nitrogen as this could cause the ignition limit to shift into the critical range.

- Carry out the leak test on the refrigerating plant in accordance with EN 378-2 or a corresponding safety standard, while always observing the maximum permissible overpressure for the compressor.

6 | Commissioning

6.4 Evacuation



ATTENTION Do not start the compressor if it is under vacuum. Do not apply any voltage - even for test purposes (must only be operated with refrigerant).

Under vacuum, the spark-over and creepage current distances of the terminal board connection bolts shorten; this can result in winding and terminal board damage.

- First evacuate the **system** and then include **the compressor in the evacuation process**.
- Relieve the compressor pressure.
- Open the suction and pressure line shut-off valves.
- Turn on the oil sump heater.
- Evacuate the suction and discharge pressure sides using the vacuum pump.
- At the end of the evacuation process, the vacuum should be < 1.5 mbar when the pump is switched off.
- Repeat this process as often as is required.

6.5 Refrigerant charge



CAUTION Wear personal protective clothing such as goggles and protective gloves!

GB

- Make sure that the suction and pressure line shut-off valves are open.



INFO Depending upon design of the CO₂ refrigerant filling bottle (with/without tubing) CO₂ can be filled in liquid after weight or gaseously.

Use only high-dried CO₂ quality (see chapter 3.1)!

- **Filling the liquid refrigerant:** It is recommended that the system first be filled at standstill with gas on the high-pressure side up to a system pressure of at least 5.2 bar (if it is filled below 5.2 bar with liquid, there is a risk of dry ice formation). Further filling according to system.
To eliminate the possibility of dry ice formation when the system is operating (during and after the filling process), the shut-off point of the low-pressure switch should be set to a value of at least 5.2 bar.



WARNING Never exceed the max. permissible pressures while charging. Precautions must be taken in time.

- A refrigerant supplement, which may become necessary after start-up, can be topped up in vapour form on the suction side.



- ATTENTION**
- Avoid overfilling the machine with refrigerant!
 - Do not charge liquid refrigerant into the suction-side on the compressor.
 - Do not mix additives with the oil and refrigerant.

6 | Commissioning

6.6 Start-up



WARNING Ensure that both shut-off valves are open before starting the compressor!

- Check that the safety and protection devices (pressure switch, motor protection, electrical contact protection measures, etc.) are functioning properly.
- Switch on the compressor and let it run for at least 10 minutes.
- The machine should reach a state of equilibrium.
- Check the **oil level**: The oil level must be visible in the sight glass.
- After a compressor is replaced, the oil level must be checked again. If the level is too high, oil must be drained off (danger of oil liquid shocks; reduced capacity of the refrigerating system).



ATTENTION If larger quantities of oil have to be topped up, there is a risk of oil impact effects. If this is the case, check the oil return!

6.7 Decompression valves



ATTENTION The compressor is fitted with two decompression valves. One valve each on the suction and discharge side. If excessive pressures are reached, the valves open and prevent further pressure increase.

Thereby CO₂ is blown off to the ambient!

In the event that a pressure relief valve activates repeatedly, check valve and replace if necessary as during blow-off extreme conditions can occur, which may result in a permanent leak. Always check system for refrigerant loss after activation of pressure relief valve!

The decompression valves do not replace any pressure switches and the additional safety valves in the system. Pressure switches must always be installed in the system and designed or adjusted in accordance with EN 378-2 or appropriate safety standards.

Failure to observe can result in risk of injury from CO₂ streaming out of the two decompression valves!

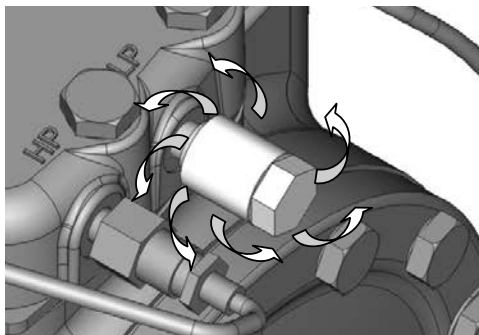

CO₂ streaming out

Fig. 15

6 | Commissioning

6.8 Avoid slugging



ATTENTION Slugging can result in damage to the compressor and cause refrigerant to leak.

To prevent slugging:

- The complete refrigeration system must be properly designed.
- All components must be compatibly rated with each other with regard to output (particularly the evaporator and expansion valves).
- Suction gas superheat at the compressor input **should be 15 K**. (Check the setting of the expansion valve).
- Regard oil temperature and pressure gas temperature. (The pressure gas temperature has to be high enough min. 50°C, so the oil temperature is > 30°C).
- The system must reach a state of equilibrium.
- Particularly in critical systems (e.g. several evaporator points), measures are recommended such as replacement of liquid traps, solenoid valve in the liquid line, etc.

There should be no movement of coolant whatsoever while the compressor is at a standstill.

6.9 Filter dryer

Gaseous CO₂ has a significantly lower solubility in water than other refrigerants. At low temperatures it can therefore cause blocking of valves and filters due to ice or hydrate. For this reason we recommend the use of an adequately sized filter drier and a sight glass with a moisture indicator.

GB

6.10 Connection of oil level regulator

The connection "O" is provided for installing an oil level regulator. A corresponding adapter must be obtained from the trade.

7 | Maintenance

7.1 Preparation



WARNING

Before starting any work on the compressor:

- Switch off the compressor and secure it to prevent a restart.
- Relieve compressor of system pressure.
- Prevent air from infiltrating the system!

After maintenance has been performed:

- Connect safety switch.
- Evacuate compressor.
- Release switch-on lock.

7.2 Work to be carried out

In order to guarantee optimum operational reliability and service life of the compressor, **we recommend** carrying out servicing and inspection work at regular intervals:

● Oil change:

- not mandatory for factory-produced series systems.
- for field installations or when operating near the application limit: for the first time after 100 to 200 operating hours, then approx. every 3 years or 10,000 - 12,000 operating hours. Dispose of used oil according to the regulations; observe national regulations.

- **Annual checks:** Oil level, leak tightness, running noises, pressures, temperatures, function of auxiliary devices such as oil sump heater, pressure switch.

7.3 Spare part recommendation/accessories

Available spare parts and accessories can be found on our compressor selection tool under **vap.bock.de** as well as at **bockshop.bock.de**.

Only use genuine Bock spare parts!

7 | Maintenance

7.4 Extract from the lubricants table

For operation with CO₂ the Bock oil BOCKlub E85 is necessary!

7.5 Decommissioning

Close the shut-off valves on the compressor. CO₂ does not need to be recycled and can therefore be blown off into the environment. It is essential to ensure good ventilation or conduct the CO₂ into the outdoors to avoid danger of suffocation. When releasing CO₂, avoid a fast drop in pressure to prevent oil from exiting with it. If the compressor is unpressurized, remove the piping on the pressure- and suction-side (e.g. dismantling of the shut-off valve, etc.) and remove the compressor using an appropriate hoist. Dispose of the oil inside in accordance with the applicable national regulations.

When decommissioning the compressor (eg. for service or replacement of the compressor) larger amounts of CO₂ in the oil can be set free. If the decompression of the compressor is not sufficient enough, closed shut-off valves may lead to intolerable excessive pressure. For this reason the suction side (LP) and the high pressure side (HP) of the compressor have to be secured by decompression valves.

GB

8 | Technical data

Type	No. of cylinders	Displacement 50 / 60 Hz (1450 / 1740 rpm)	Electrical data ^③				Oil charge					
			Voltage ^①	Max. Operating current ^② Δ / Y	Max. power consumption ^②	Starting current (rotor locked) Δ / Y		Weight				
		m ³ /h	A	kW	A	kg	Discharge line DV	Suction line SV	Connections ^④			
HGX22e/85-4 S CO ₂	2	7,5 / 9,0	220-240 V Δ / 380-420 V Y - 3 - 50 Hz 265-290 V Δ / 440-480 V Y - 3 - 60 Hz	15,6 / 9,0	5,2	111 / 64	82	16 ^(5/8)	22 ^(7/8)	1,0		
								18,5 / 10,7	6,4		111 / 64	82
								22,3 / 12,9	7,8		111 / 64	82
HGX22e/105-4 S CO ₂	2	9,2 / 11,1										
HGX22e/130-4 S CO ₂		11,2 / 13,4										

^① Tolerance (\pm 10%) relative to the mean value of the voltage range.

Other voltages and types of current on request.

^② These are preliminary values and can differ from the actual values!

- The specifications for max. power consumption apply for 50Hz operation.

For 60Hz operation, the specifications have to be multiplied by the factor

1.2. The max. working current remains unchanged.

- Take account of the max. operating current / max. power consumption for design of fuses, supply lines and safety devices. Fuse: Consumption category AC3

^③ All specifications are based on the average of the voltage range

^④ For solder connections

8 Technical data

Type	No. of cylinders	Displacement 50 / 60 Hz (1450 / 1740 rpm)	Electrical data ^③			Weight	Connections ^④		Oil charge
			Voltage ^①	Max. Operating current ^② Δ / Y	Max. power consumption ^②		Starting current (rotor locked) Δ / Y	Discharge line DV	
HGX34e/145-4 S CO ₂		12,7 / 15,2	A	kW	A	kg	mm (inch)	mm (inch)	Ltr.
			26,3 / 15,2	8,8	169 / 98				
HGX34e/170-4 S CO ₂	4	14,9 / 17,9	30,1 / 17,4	10,3	169 / 98	103	22 (7/8)	28 1 (1/8)	1,2
			36,7 / 21,2	12,8	169 / 98	102			
HGX43e/210-4 S CO ₂		18,4 / 22,0	44,8 / 25,9	15,8	178 / 103	104			
HGX43e/255-4 S CO ₂		22,3 / 26,8							

^① Tolerance (\pm 10%) relative to the mean value of the voltage range.

Other voltages and types of current on request.

^② These are preliminary values and can differ from the actual values!

- The specifications for max. power consumption apply for 50Hz operation.

For 60Hz operation, the specifications have to be multiplied by the factor

1.2. The max. working current remains unchanged.

- Take account of the max. operating current / max. power consumption for design of fuses, supply lines and safety devices. Fuse: Consumption category AC3

^③ All specifications are based on the average of the voltage range

^④ For solder connections

9 | Dimensions and connections

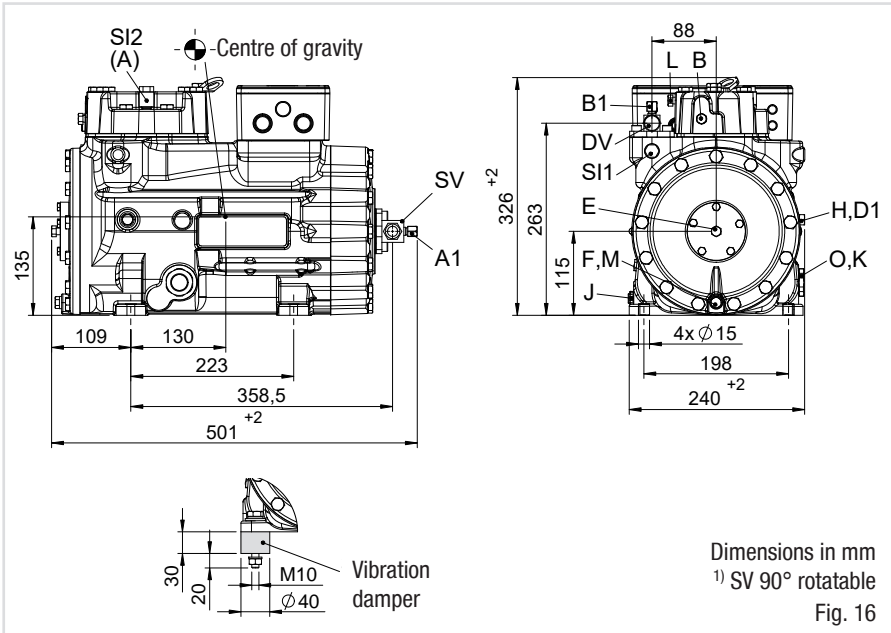

SV	Suction line	see technical data, Chapter 8
DV	Discharge line	
A*	Connection suction side, not lockable	1/8" NPTF
A1	Connection suction side, lockable	7/16" UNF
B	Connection discharge side, not lockable	1/8" NPTF
B1	Connection discharge side, lockable	7/16" UNF
D1	Connection oil return from oil separator	1/4" NPTF
E	Connection oil pressure gauge	1/8" NPTF
F	Oil drain	M12x1,5
H	Oil charge plug	1/4" NPTF
J	Connection oil sump heater	3/8" NPTF
K	Sight glass	1 1/8" - 18 UNEF
L**	Connection thermal protection thermostat	1/8" NPTF
M	Oil strainer	M12x1,5
O	Connection oil level regulator	1 1/8" - 18 UNEF
SI1	Pressure relief valve HD	1/8" NPTF
SI2	Pressure relief valve ND	1/8" NPTF

* = only possible with additional adapter

** = no connection discharge side

9|Dimensions and connections

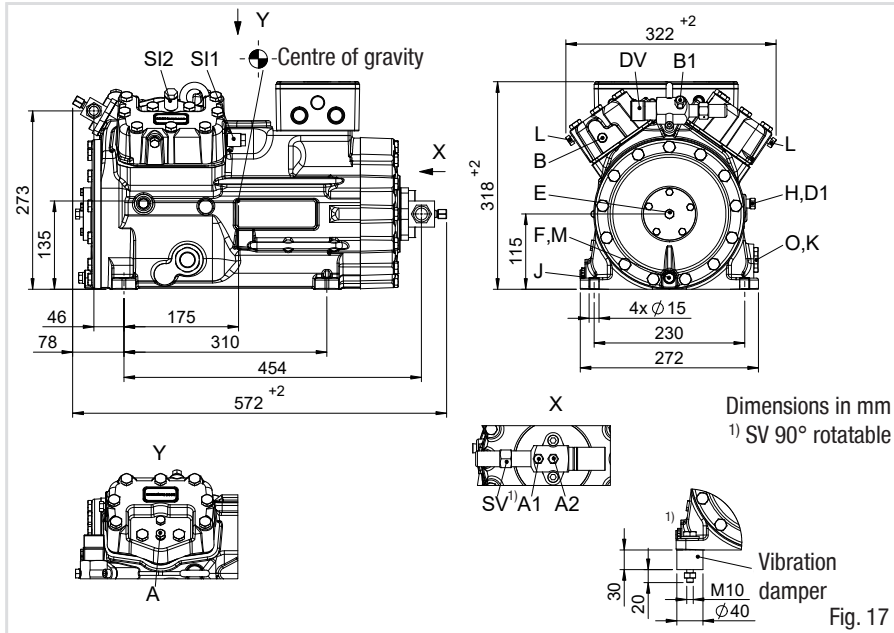

GB

SV	Suction line	see technical data, Chapter 8	
DV	Discharge line	see technical data, Chapter 8	
A*	Connection suction side, not lockable		1/8" NPTF
A1	Connection suction side, lockable		7/16" UNF
A2	Connection suction side, not lockable		1/8" NPTF
B	Connection discharge side, not lockable		1/8" NPTF
B1	Connection discharge side, lockable		7/16" UNF
D1	Connection oil return from oil separator		1/4" NPTF
E	Connection oil pressure gauge		1/8" NPTF
F	Oil drain		M12x1,5
H	Oil charge plug		1/4" NPTF
J	Connection oil sump heater		3/8" NPTF
K	Sight glass		1 1/8" - 18 UNEF
L**	Connection thermal protection thermostat		1/8" NPTF
M	Oil strainer		M12x1,5
O	Connection oil level regulator		1 1/8" - 18 UNEF
SI1	Pressure relief valve HD		1/8" NPTF
SI2	Pressure relief valve ND		1/8" NPTF

* = only possible with additional adapter

** = no connection discharge side

10 | Declaration of installation

Declaration of incorporation for incomplete machinery in accordance with EC Machinery Directive 2006/42/EC, Annex II 1. B

Manufacturer: Bock GmbH
Benzstraße 7
72636 Frickenhausen, Germany

We, as manufacturer, declare in sole responsibility that the incomplete machinery

Name: Semi-hermetic compressor
Types: HG(X)12P/60-4 S (HC) HG(X)88e/3235-4(S) (HC)
HGX12P/60 S 0,7 LG HGX88e/3235 (ML/S) 95 LG
HG(X)22(P)(e)/125-4 A HG(X)34(P)(e)/380-4 (S) A
HGX34(P)(e)/255-2 (A) HGX34(P)(e)/380-2 (A)(K)
HA(X)12P/60-4 HA(X)6/1410-4
HAX22e/125 LT 2 LG HAX44e/665 LT 14 LG
HGX12e/20-4 (ML/S) CO₂ (LT) ... HGX44e/665-4 (ML/S) CO₂ (LT)
HGX2/70-4 CO₂T HGX46/440-4 (ML/S/SH) CO₂ T
HGZ(X)7/1620-4 HGZ(X)7/2110-4

Name: Open type compressor
Types: AM(X)2/58-4 AM(X)5/847-4
F(X)2 F(X)88/3235 (NH3)
FK(X)1 FK(X)3
FK(X)20/120 (K/N/TK)..... FK(X)50/980 (K/N/TK)

Serial number: BC0000A001 – BH99999Z999

GB

complies with the following provisions of the above-mentioned Directive:

According to Annex I, points 1.1.2, 1.1.3, 1.1.5, 1.3.2, 1.3.3, 1.3.7, 1.5.1, 1.5.2, 1.5.13 and 1.7.1 to 1.7.4 (excepted 1.7.4 f) are fulfilled.

Applied harmonised standards, in particular:

EN ISO 12100 :2010 Safety of machinery — General principles for design — Risk assessment and risk reduction
EN 12693 :2008 Refrigerating systems and heat pumps — Safety and environmental requirements — Positive displacement refrigerant compressors

Remarks: We also declare that the special technical documentation for this incomplete machine has been created in accordance with Annex VII, Part B and we obligate to provide these upon reasoned request from the individual national authorities by data transfer.

Commissioning is prohibited until it has been confirmed that the machinery into which the incomplete machine above is to be incorporated complies with the EC Machinery Directive and an EC Declaration of Conformity, Annex II. 1. A exists.

Authorized person for compiling and handing over technical documentation:

Bock GmbH
Alexander Layh
Benzstraße 7
72636 Frickenhausen, Germany

Frickenhausen, 04th of January 2021



i. A. Alexander Layh, Technical director

96422-06.2021-DGbFEI

11 | Service

Dear customer,

if you have any questions about installation, operation and accessories, please contact our technical service or specialist wholesaler and/or our representative. The Bock service team can be contacted by phone, **+49 (0)7022 9454-0** or via **service@bock.de**

Yours faithfully Bock GmbH

GB



BOCK[®]

Bock GmbH

Benzstraße 7

72636 Frickenhausen

Germany

Phone +49 7022 9454-0

Fax +49 7022 9454-137

www.bock.de