

3D-VIEW

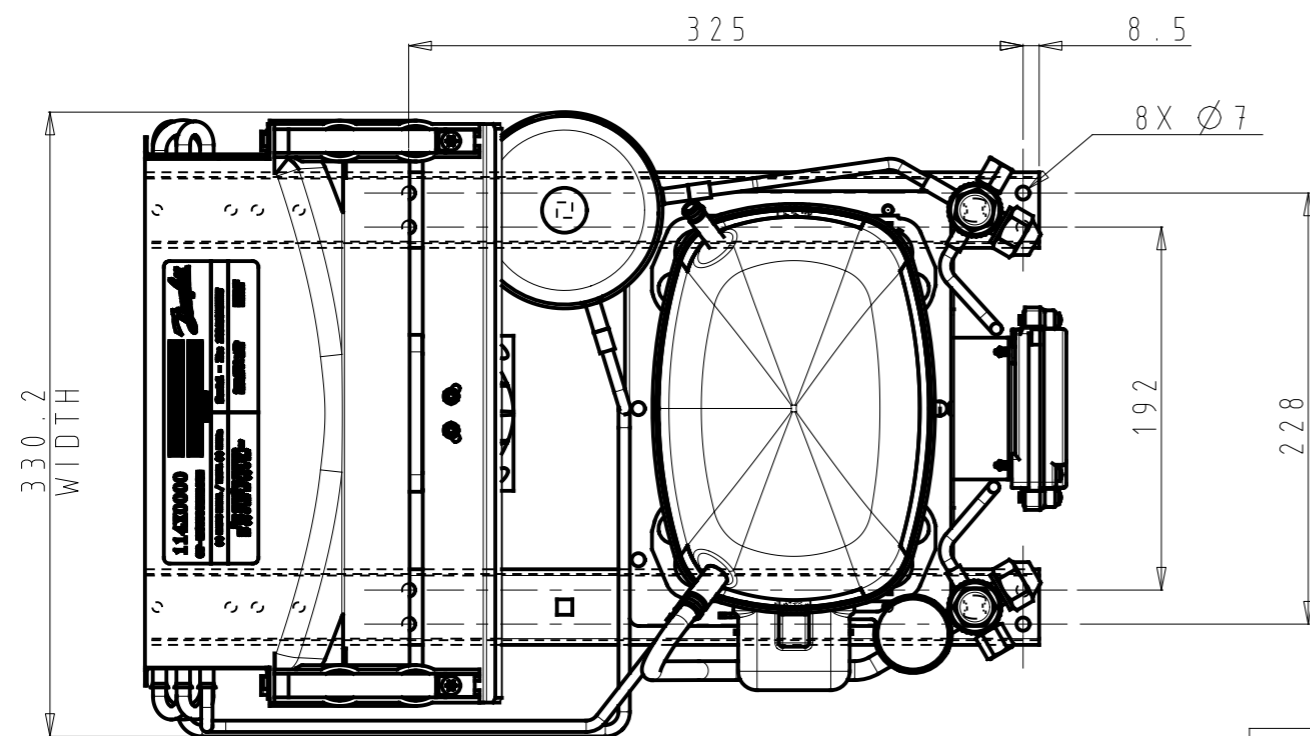

NOTE:  
1. ALL DIMENSIONS ARE IN mm.

SL. NO	UNIT	DESCRIPTION	FAN	MASS (kg)
1	114X1549	OP-LCHC015SCA01G	1X254	23

General Tolerances Table	Drawing Status :			Production print			▽ Key characteristic ⊕ Critical characteristic According to Danfoss standard 502Z0024
	±1, ±0.5°			Surface Area (m2)	--	Estimated Mass (Kg)	
Roughness (µm)	A	ECR-2019-11240	19-09-2019	Projection	Scale	Size	Material : --
	Revision	ECR Number	Date		1/4	A3	Designation
	Designer	SAS					OP-LCHC015SCA01G
	Approval	AKS					
ISO 8015 ISO 1101	Confidential: Property of Danfoss Commercial Compressors. Not to be handed over to copied or used by third party. Two or three dimensional reproduction of contents to be authorized by Danfoss CC.						Sheet 1 of 2
	A.2	Dwg N°	114X1549				A

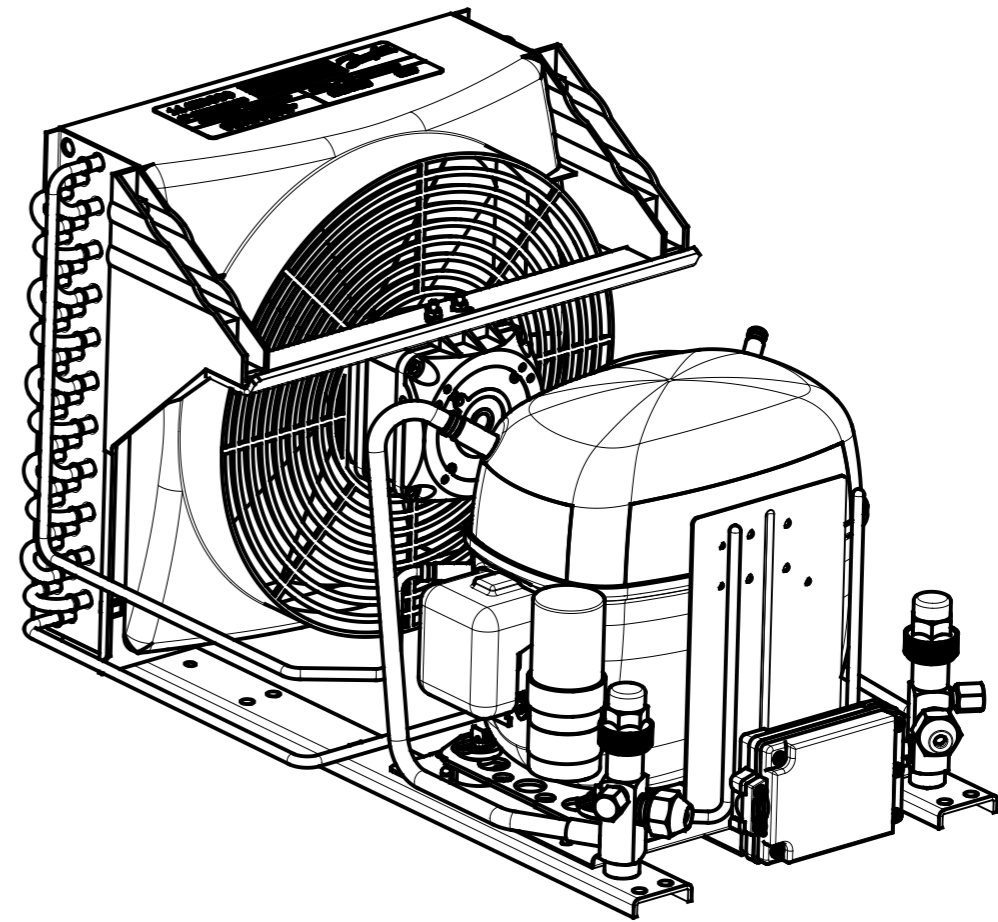
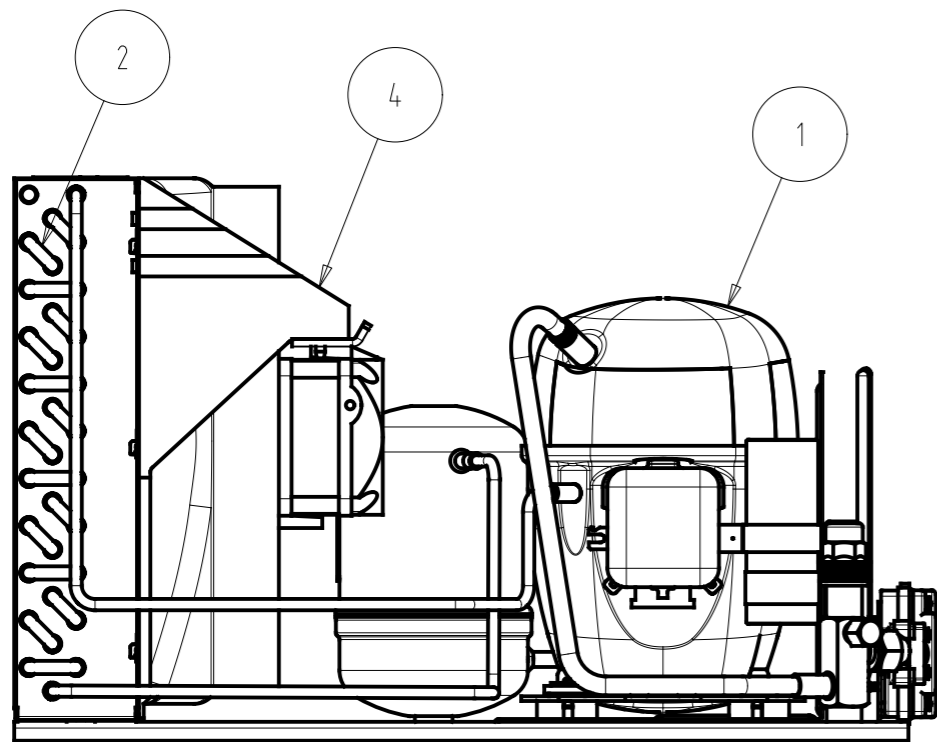

3D-VIEW

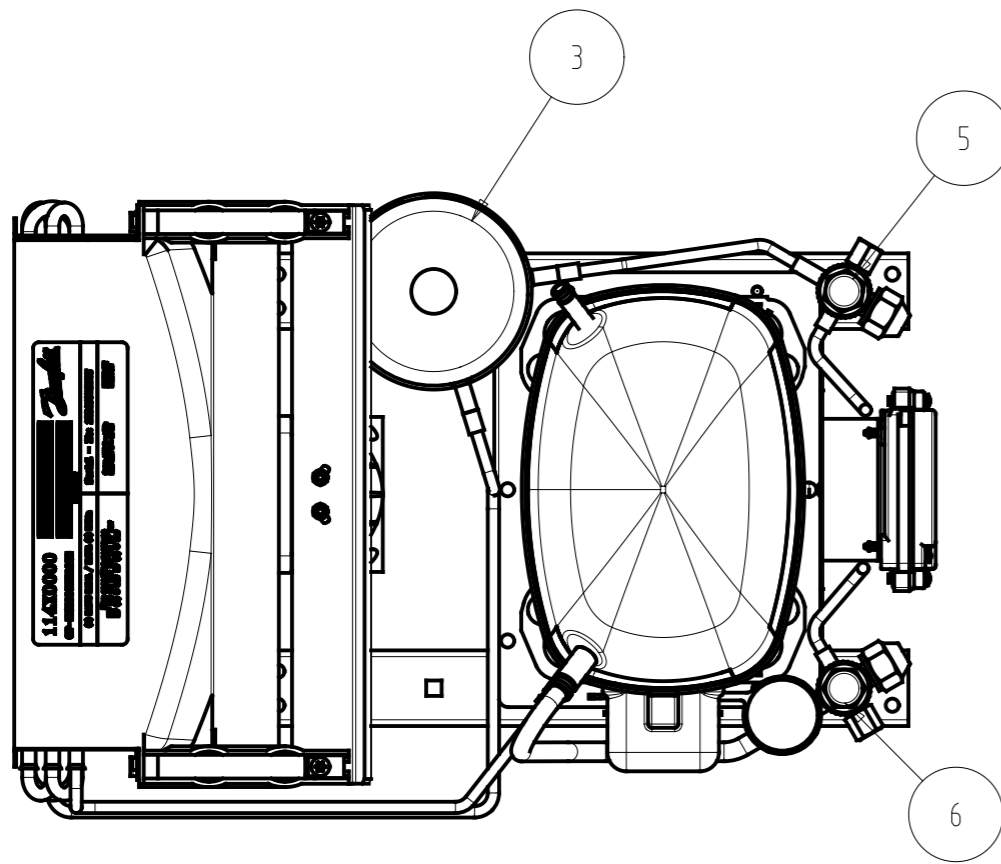

SL. NO	NAME	DESCRIPTION	QTY
1	104L2853	COMPONENT, COMPRESSOR DANFOSS SC15CLX	1
2	1130270A50	ASSEMBLY, CONDENSER FIN AND TUBE COIL	1
3	118U0528	COMPONENT, RECEIVER DANFOSS 100_169VS00	1
4	118U4024	ASSEMBLY, CONDENSER COOLING FAN	1
5	118U0480	ASSEMBLY, KP CONNECTION LIQUID VALVE 5/8 INCH	1
6	118U0487	COMPONENT, SUCTION VALVE 10mm	1

General Tolerances Table	Drawing Status :			Production print			▽ Key characteristic ⊕ Critical characteristic According to Danfoss standard 502Z0024
	±1, ±0.5°			Surface Area (m2)	--	Estimated Mass (Kg)	
Roughness (µm)	A	ECR-2019-11240	19-09-2019	Projection	Scale	Size	Material : --
	Revision	ECR Number	Date	⊕	1/4	A3	Designation
	Designer	SAS					OP-LCHC015SCA01G
	Approval	AKS					
ISO 8015 ISO 1101	Confidential: Property of Danfoss Commercial Compressors. Not to be handed over to copied or used by third party. Two or three dimensional reproduction of contents to be authorized by Danfoss CC.						Sheet 2 of 2
	A.2	Dwg N°	114X1549				A