

3D-VIEW

NOTE:
1. ALL DIMENSIONS ARE IN mm.

| SL. NO | UNIT | DESCRIPTION | FAN | MASS (kg) |
|--------|----------|------------------|-------|-----------|
| 1 | 114X1556 | OP-LCHC018SCA00G | 1X254 | 23 |

| | | | | | | | |
|---|------------------|----------------|------------|-------------------|-------|---------------------|---|
| General Tolerances Table | Drawing Status : | | | Production print | | | ▽ Key characteristic ⊕ Critical characteristic According to Danfoss standard 502Z0024 |
| | ±1, ±0.5° | | | Surface Area (m2) | -- | Estimated Mass (Kg) | |
| Roughness (µm) | A | ECR-2019-11240 | 19-09-2019 | Projection | Scale | Size | Material : -- |
| | | Revision | ECR Number | Date | 1/4 | A3 | |
| • ISO 8015 • ISO 1101 | | Designer | SAS | | | | Designation |
| | | Approval | AKS | | | | |
| Confidential: Property of Danfoss Commercial Compressors. Not to be handed over to copied or used by third party. Two or three dimensional reproduction of contents to be authorized by Danfoss CC. | | | | | | | Sheet 1 of 2 |
| | | | | | | | A.2 Dwg N° 114X1556 |

A

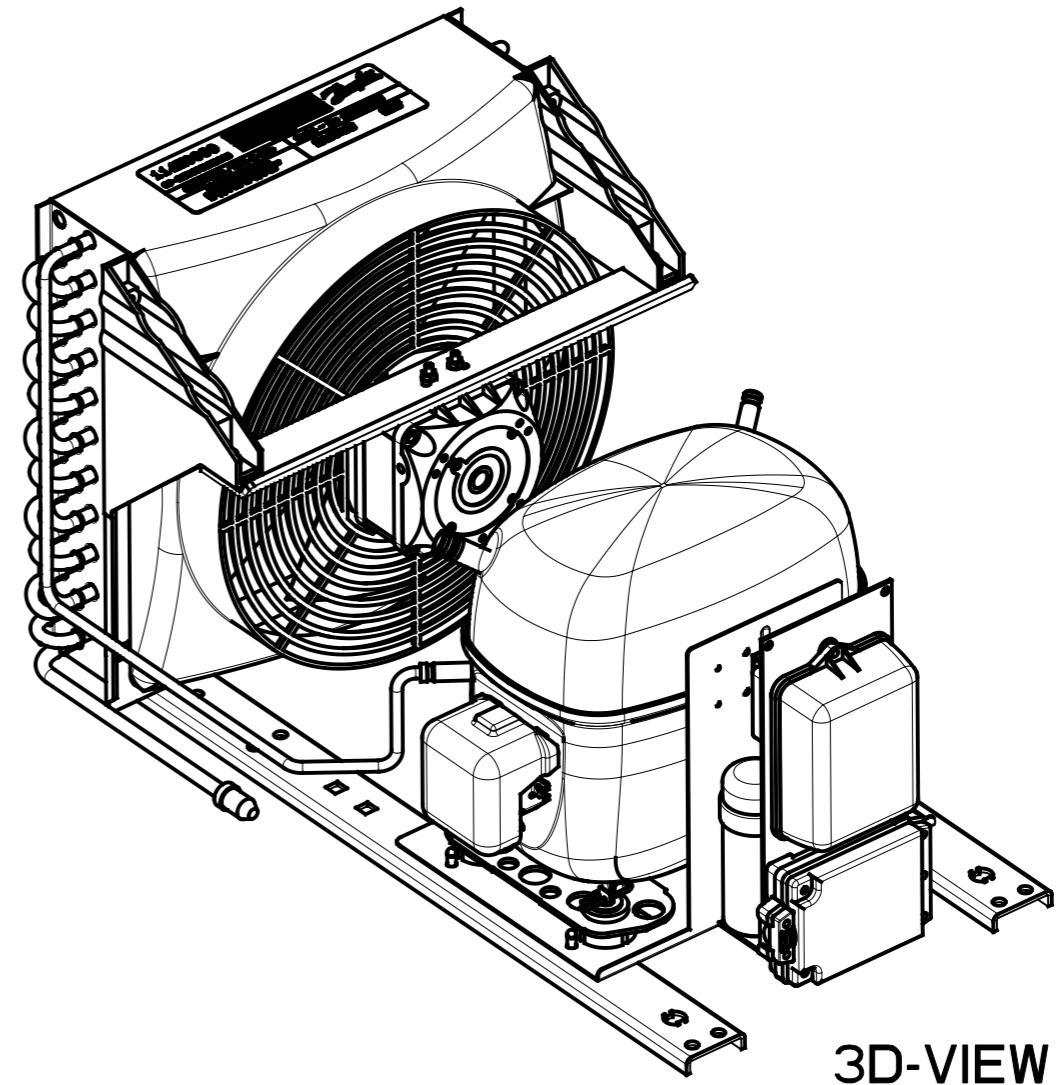
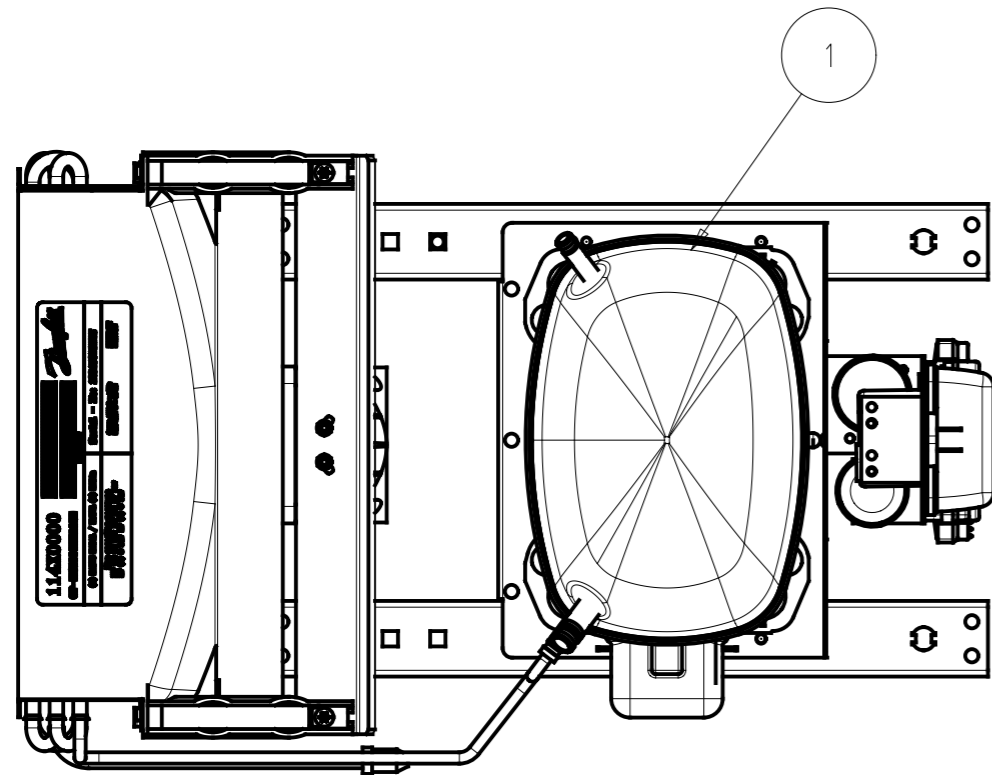
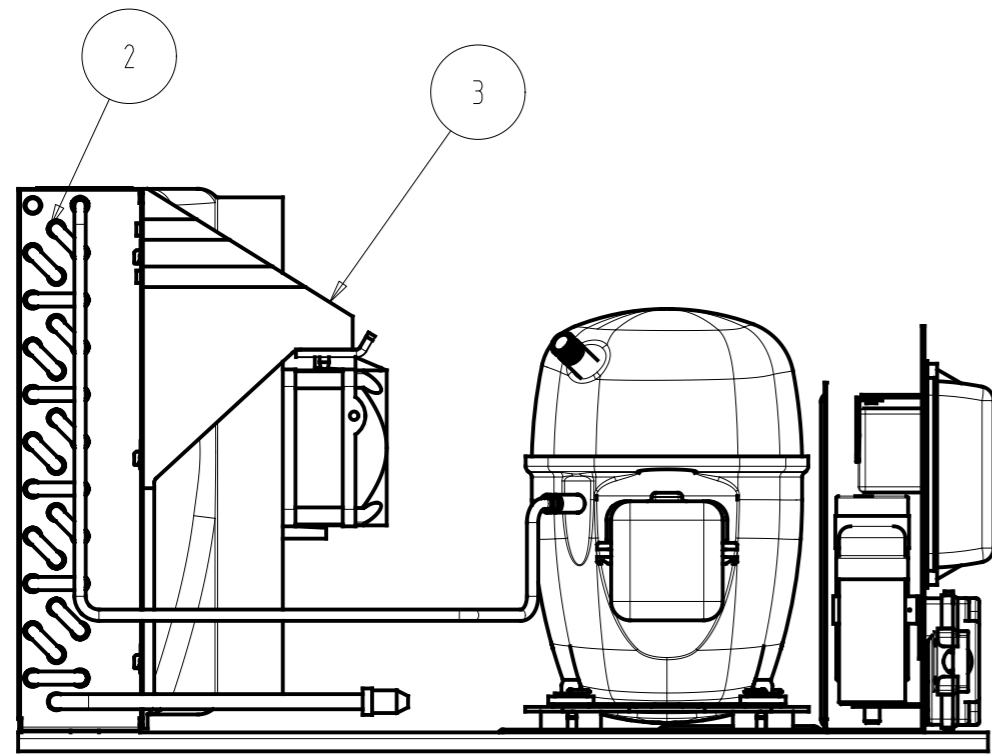

3D-VIEW

| SL. NO | NAME | DESCRIPTION | QTY |
|--------|------------|---------------------------------------|-----|
| 1 | 104L2123 | ASSEMBLY, COMPRESSOR DANFOSS SC18CL | 1 |
| 2 | 1130270A50 | ASSEMBLY, CONDENSER FIN AND TUBE COIL | 1 |
| 3 | 118U4024 | ASSEMBLY, CONDENSER COOLING FAN | 1 |

| | | | | | | | |
|--------------------------|---|----------------|------------|-------------------|-------|---------------------|---|
| General Tolerances Table | Drawing Status : | | | Production print | | | ▽ Key characteristic ⊕ Critical characteristic According to Danfoss standard 502Z0024 |
| | ±1, ±0.5° | | | Surface Area (m2) | -- | Estimated Mass (Kg) | |
| Roughness (µm) | A | ECR-2019-11240 | 19-09-2019 | Projection | Scale | Size | Material : -- |
| | Revision | ECR Number | Date | | 1/4 | A3 | Designation |
| | Designer | SAS | | | | | OP-LCHC018SCA00G |
| | Approval | AKS | | | | | |
| ISO 8015 ISO 1101 | Confidential: Property of Danfoss Commercial Compressors. Not to be handed over to copied or used by third party. Two or three dimensional reproduction of contents to be authorized by Danfoss CC. | | | | | | Sheet 2 of 2 |
| | A.2 | Dwg N° | 114X1556 | | | | A |