

3D-VIEW

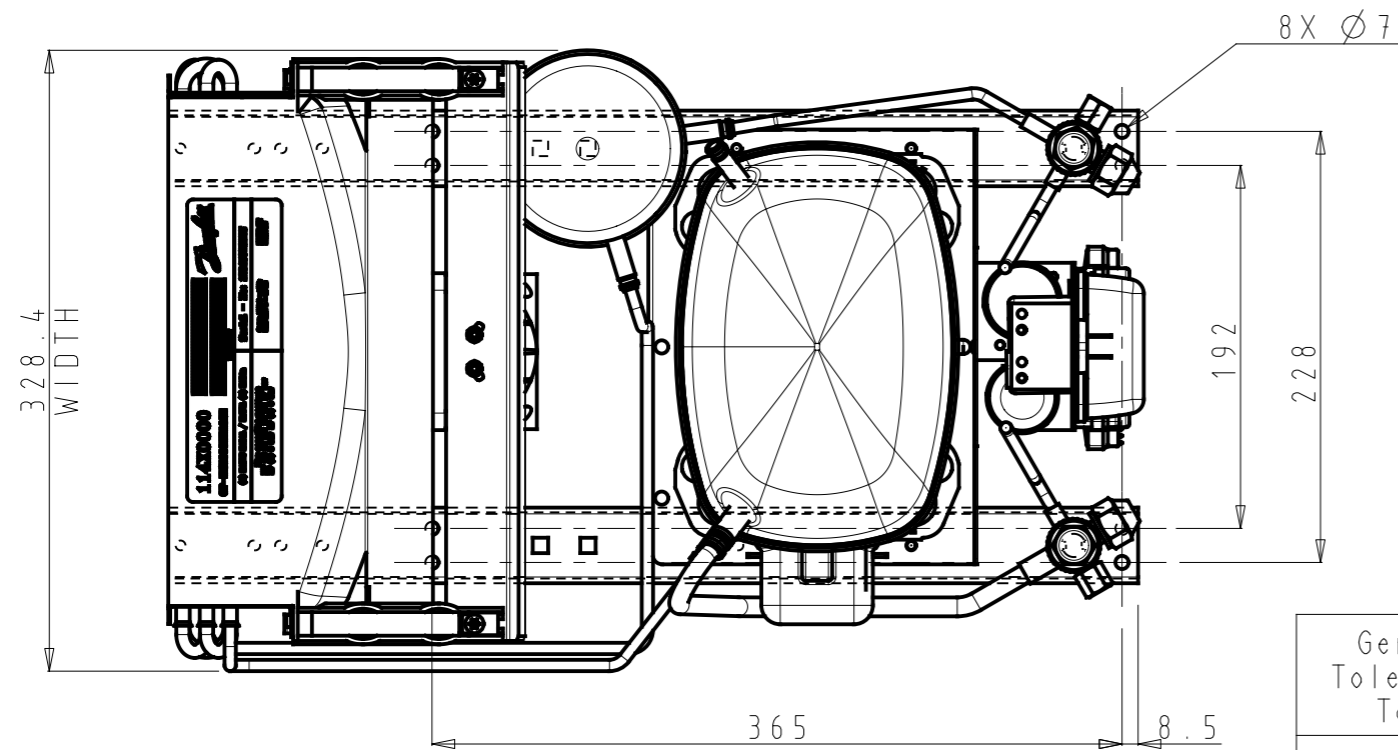

NOTE:
1. ALL DIMENSIONS ARE IN mm.

SL. NO	UNIT	DESCRIPTION	FAN	MASS (kg)
1	114X1565	OP-LCHC021SCA01G	1X254	36.9

General Tolerances Table	Drawing Status :			Production print			▽ Key characteristic ⊕ Critical characteristic According to Danfoss standard 502Z0024
	±1, ±0.5°			Surface Area (m2)	--	Estimated Mass (Kg)	
Roughness (µm)	A	ECR-2019-11240	10-10-2019	Projection	Scale	Size	Material : -- Designation
		Revision	ECR Number	Date	1/4	A3	
ISO 8015 ISO 1101	Approval						OP-LCHC021SCA01G Sheet 1 of 2 A.3 Dwg N° 114X1565
Confidential: Property of Danfoss Commercial Compressors. Not to be handed over to copied or used by third party. Two or three dimensional reproduction of contents to be authorized by Danfoss CC.			A				

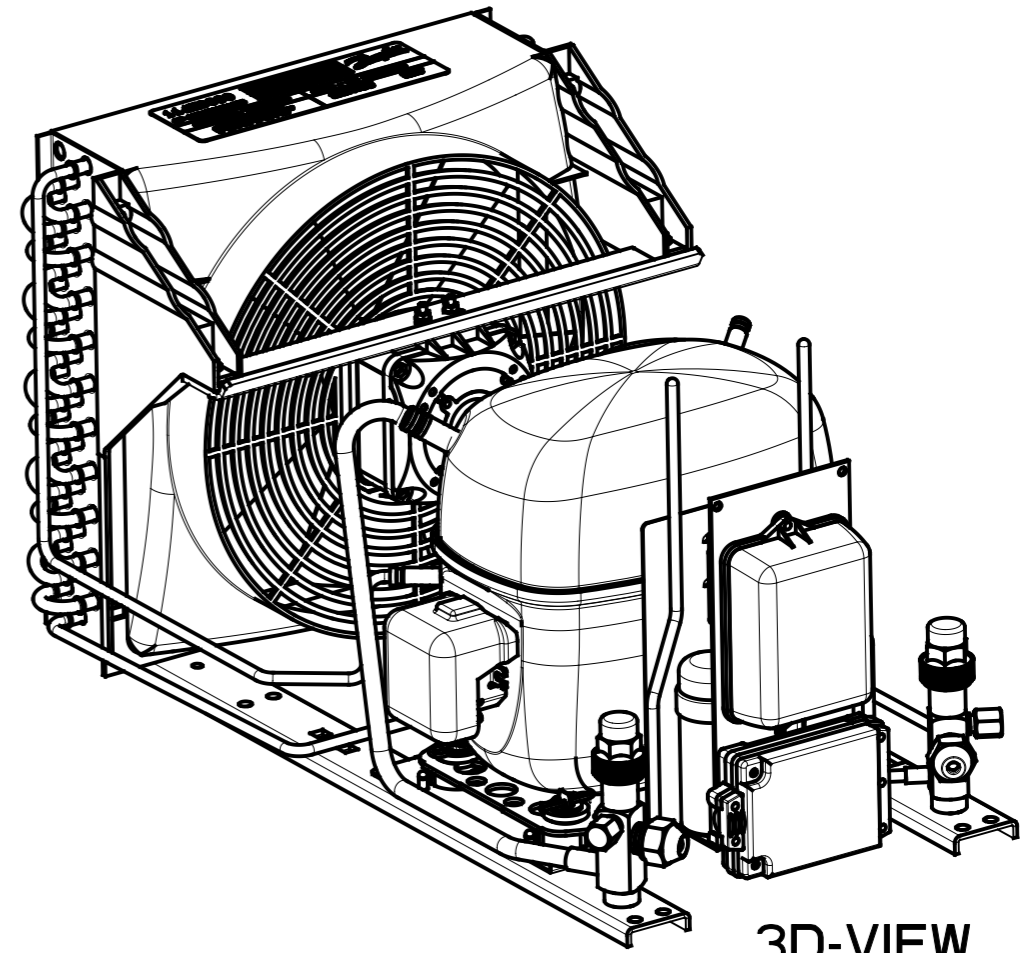
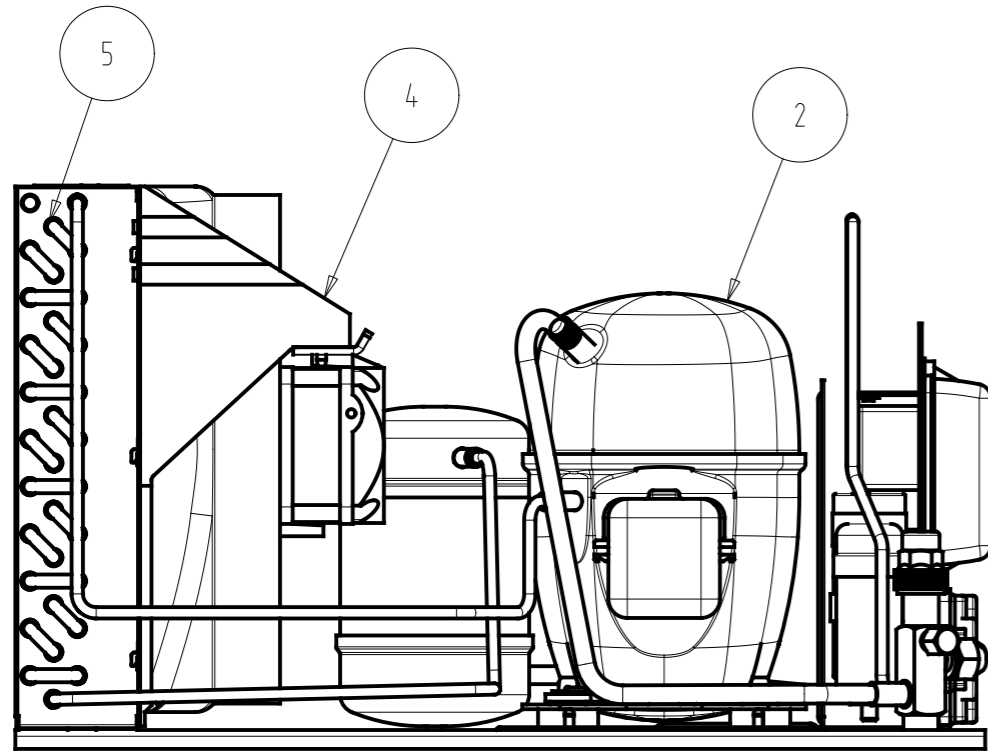

3D-VIEW

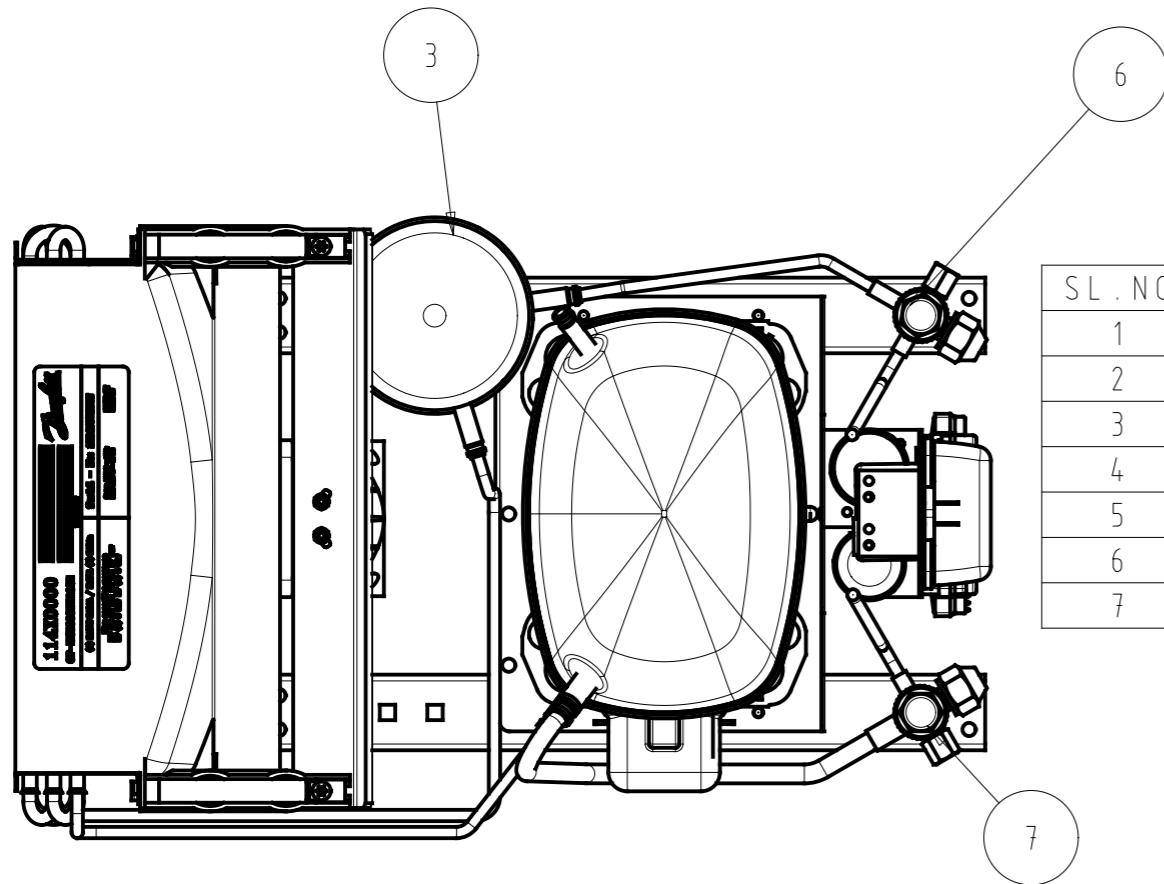

SL. NO	NAME	DESCRIPTION	QTY
1	92514736	ASSEMBLY, COMPRESSOR BASE PLATE	1
2	104L2322	ASSEMBLY, COMPRESSOR DANFOSS SC21CL	1
3	118U0515	COMPONENT, RECEIVER DANFOSS 100_169VS00	1
4	118U4024	ASSEMBLY, CONDENSER COOLING FAN	1
5	1130270A50	ASSEMBLY, CONDENSER FIN AND TUBE COIL	1
6	118U0480	ASSEMBLY, KP CONNECTION LIQUID VALVE 5/8 INCH	1
7	118U0487	COMPONENT, SUCTION VALVE 10mm	1

General Tolerances Table	Drawing Status :			Production print			▽ Key characteristic ⊕ Critical characteristic According to Danfoss standard 502Z0024
	±1, ±0.5°			Surface Area (m2)	--	Estimated Mass (Kg)	
Roughness (µm)	A	ECR-2019-11240	10-10-2019	Projection	Scale	Size	Material : --
		Revision	ECR Number	Date	1/4	A3	Designation
ISO 8015 ISO 1101		Designer	SAS				OP-LCHC021SCA01G
		Approval	AKS				Sheet 2 of 2
Confidential: Property of Danfoss Commercial Compressors. Not to be handed over to copied or used by third party. Two or three dimensional reproduction of contents to be authorized by Danfoss CC.				A.3	Dwg N°	114X1565	A