

3D-VIEW

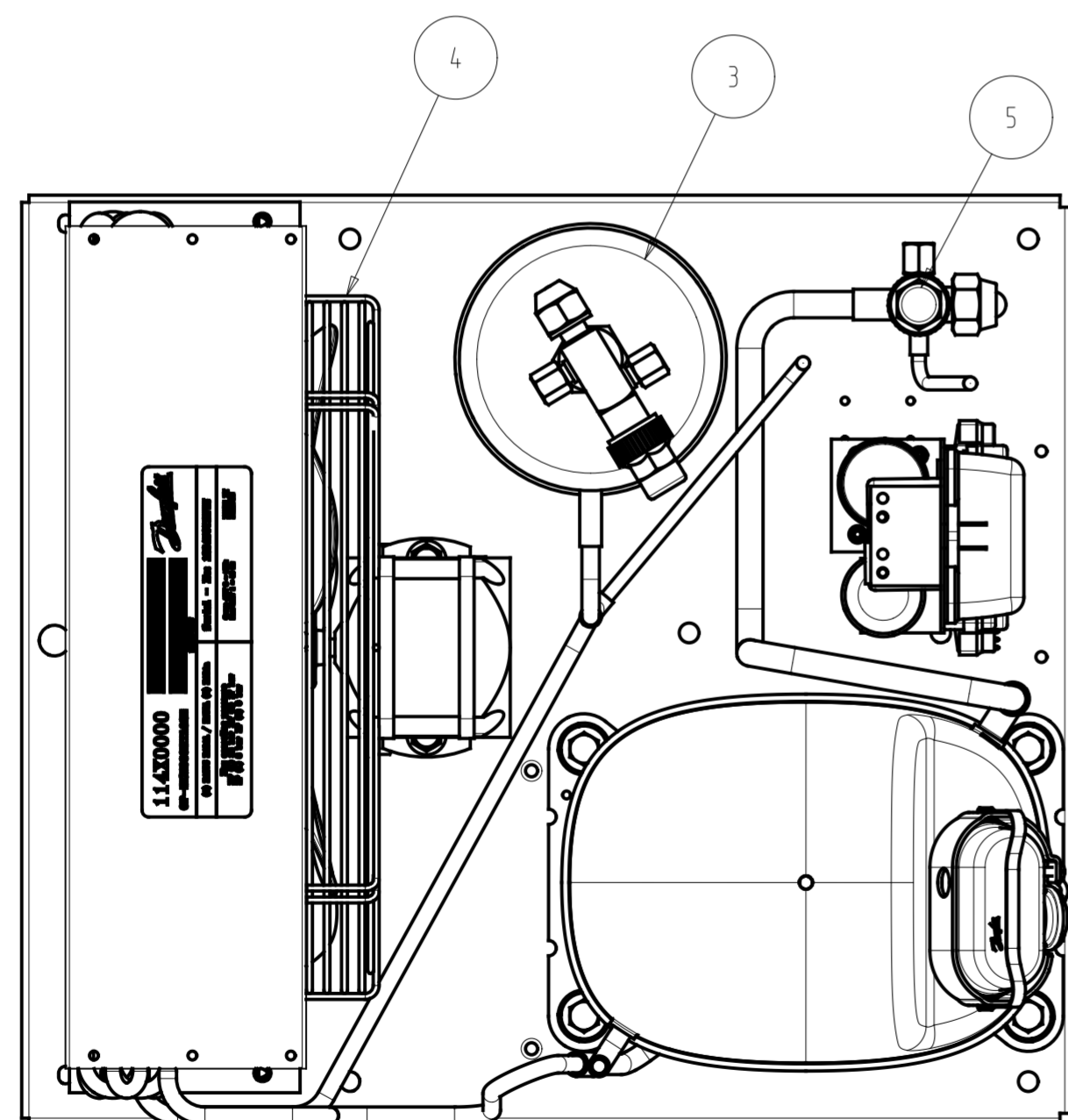

SL. NO	NAME	DESCRIPTION	QTY
1	GS26CLX_LIGHT	GS26CLX_Light	1
2	118U0156	ASSEMBLY, CONDENSER COIL 1240360C50	1
3	118U0539	COMPONENT, RECEIVER DANFOSS 120_252VK00	1
4	118B0010	ASSEMBLY, FAN GRILL 118U0156	1
5	118U0572	COMPONENT, LIQUID VALVE 15mm	1
6	118U0574	COMPONENT, ROTALOCK VALVE 5/8 INCH	1

General Tolerances Table	Drawing Status :			Production print			▽ Key characteristic ⊕ Critical characteristic According to Danfoss standard 50220024
	±1, ±0.5°			Surface Area (m2)	--	Estimated Mass (Kg)	
Roughness (µm)	A	ECR-2019-11240	09-10-2019	Projection	1/4	Size	A2
	Revision	ECR Number	Date			Material : --	
	Designer	SAS				Designation	
	Approval	AKS				OP-LCHC026GSA01G	
ISO 8015 ISO 1101	Confidential: Property of Danfoss Commercial Compressors. Not to be handed over to copied or used by third party. Two or three dimensional reproduction of contents to be authorized by Danfoss CC.			Sheet 2 of 2		A.2 Dwg N° 114X1673	

A