

Content

1. OverView.....	4
1.1 Nomenclature.....	4
1.2 Product feature.....	4
1.3 Nameplate	4
2. Specification.....	5
2.1 Specification parameters.....	5
3. Capacity control system.....	6
3.1 Compression process.....	6
3.2 Step capacity control system.....	6
4. Electrical parameters and design.....	11
4.1 Start-up.....	11
4.2 Start-up limit.....	12
4.3 MCC&LRA.....	13
4.4 Wiring diagram of terminal cover plate.....	14
4.5 Grounding.....	14
5. Accessories.....	16
5.1 Standard Accessories and Optional Accessories.....	16
5.2 Accessories Introduction	17
6. Lubricating oil.....	30
6.1 Lubricant configuration	30
6.2 Pre-cautions for changing oil.....	31
6.3 The Replacement of Lubricating oil.....	31
7. System Application	32
7.1 Principle& Application of economizer	32
7.2 Application of pressure maintaining valve	33
7.3 Application of parallel connection system.....	34
7.4 Discharge temperature control - oil cooler application	34
7.5 Motor temperature control - Application of liquid injection	36
7.6 Key points for compressor application	37
8. Operation and Maintenance.....	38
8.1 Compressor Installation.....	38
8.2 Compressor maintenance.....	41
9. Operation Range	44
10. Appearance Drawing.....	46
10.1 RC2-100~930D-S Drawing	46
10.2 RC2-100~930D-P Drawing	51
11. Connector Size	56
11.1 Connector size of single model	56
11.2 Connector size of model in parallel connection.....	57

1. Overview

RC2-D is a special single-stage screw compressor which is specially developed for the use characteristics of the refrigeration market. This series are suitable for various refrigeration applications including high, medium and low temperature. Compared with the previous generation products, RC2-D series have higher reliability and operation efficiency.

This technical manual covers the operation, dimensions, installation, accessories, application and basic troubleshooting of the compressor. It is recommended to read this technical manual carefully before designing, installing, operating and maintaining the compressor to avoid unnecessary damage to the compressor.

1.1 Nomenclature

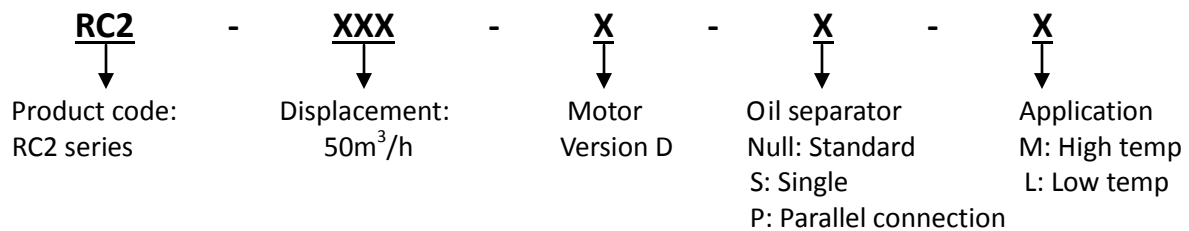

1.2 Product feature

● High performance

With stop valve of the economizer, the design of the economizer connector is optimized to improve the performance of the economizer. Motor temperature sensor and the throttle mechanism are adopted to reduce the influence of the motor liquid injection on the system performance.

● Stable and reliable

Optimized motor cooling channel design comprehensively reduce the motor temperature, improve the safety margin; upgrade the capacity control mechanism, use more superior sealing materials, further improve the capacity adjustment stability.

● Product segmentation

The whole series is subdivided into M series and L series, of which M series can meet the application needs of high temperature refrigeration, and L series can meet the application needs of medium and low temperature refrigeration.

1.3 Nameplate

螺杆制冷压缩机 SCREW COMPRESSORS			
机型 MODEL	<input type="text"/>	生产日期 MFG. DATE	<input type="text"/>
编号 SERIAL N.	<input type="text"/>	转速 RATED SPEED	<input type="text"/> RPM
排气量 DISPLACEMENT	<input type="text"/> m ³ /h	电机 MOTOR 3φ, 2P VI	<input type="text"/>
启动方式 STARTING-UP	<input type="text"/>		
额定 MAIN	<input type="text"/> V	辅助 AUX.	<input type="text"/> V
	<input type="text"/> Hz		<input type="text"/> Hz
最高工作压力 MAXIMUM WORKING PRESSURE	<input type="text"/>		<input type="text"/> MPa
启动电流 LOCKED ROTOR CURRENT	<input type="text"/>		<input type="text"/> A
最大运行电流 MAXIMUM CONTINUOUS CURRENT	<input type="text"/>		<input type="text"/> A
冷冻油 LUBRICANT	<input type="text"/>		<input type="text"/> L
压缩机质量 WEIGHT	<input type="text"/> kg	制冷剂 REFRIGERANT	<input type="text"/>
气体实验 PNEUMATIC PRESSURE TEST	3.5MPa		
许可证 CERTIFICATION OF MANUFACTURE	<input type="text"/>		

2. Specification

2.1 Specification parameters

Model	Compressor			Motor					Lubricant	Oil heater	Pressure test	Weight
	Displacement 50Hzm ³ /h	Rotation 50Hz r/min	Capacity Control (100%) Step	type	Start-up	Voltage (V)50Hz	Insulation	Protection				
									L	W	Bar	kg
RC2-100D-S(P)	98	2950	33, 66, 100 25, 50, 75, 100	3-phase 2-pole squirrel cage induction motor	Y-Δ	380	Level F	PTC	7	300	35	275/270
RC2-140D-S(P)	137								7			280/275
RC2-180D-S(P)	180								7			300/330
RC2-200D-S(P)	193								8			420/410
RC2-230D-S(P)	230								14			540/520
RC2-260D-S(P)	257								14			545/525
RC2-300D-S(P)	293								16			590/570
RC2-310D-S(P)	308								14			575/555
RC2-340D-S(P)	339								16			600/580
RC2-370D-S(P)	366								16			610/590
RC2-410D-S(P)	407								15			730/700
RC2-470D-S(P)	471								18			800/770
RC2-510D-S(P)	508								20			760/730
RC2-550D-S(P)	549								23			820/790
RC2-580D-S(P)	583								20			805/775
RC2-620D-S(P)	619								23			850/810
RC2-710D-S(P)	713								28			1099/1059
RC2-790D-S(P)	791								28			1140/1100
RC2-830D-S(P)	825								28			1150/1420
RC2-930D-S(P)	929	28	1180/1140									



Note: DP series are for application of parallel connection. There are not lubricants in the compressor.

3. Capacity control system

3.1 Compression process

At the beginning of the compression cycle, as the male rotor and female rotor unmesh, gas from suction port fills the interlobe space (refer to the dark area in Figure 3-1). Refrigerant at suction pressure continues to fill it, until the trailing lobe crosses the suction area and the gas is trapped inside the interlobe space. As the male rotor and female rotor meshes, the interlobe space moves towards to discharge end and its volume decreases so that gas pressure increases consequently. Gas is discharged from the interlobe space when the leading lobe crosses the discharge port whose volume ratio is designed differently for various applications.

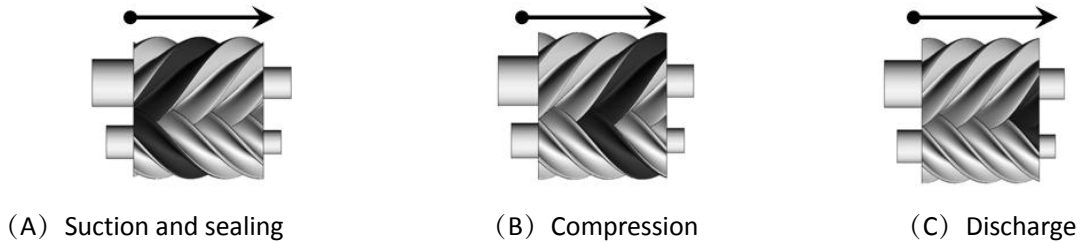

Figure 3-1 Compression process

3.2 Step capacity control system

RC2-D series screw compressors are equipped with either 3&4-step capacity control system. This capacity control systems consist of slide valve, piston rod, piston cylinder and piston ring. The slide valve and the piston are connected by a piston rod; the oil pressure in the system pushes the piston in the cylinder to move, thus the slide valve moves.

Step capacity control, as shown in Figure 3-2. The lubricating oil flows out of the oil tank and passes through the oil filter and capillary tube. As the oil pressure is higher than the sum of the right end spring force and the refrigerant pressure, the lubricating oil enters the piston cylinder. Under the action of pressure difference, the piston moves to the right, the effective compression volume in the

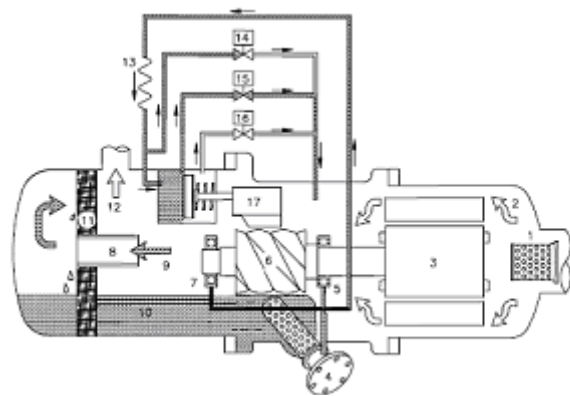

Figure 3-2 (3&4 step) Capacity control

compression chamber increase. At this time, the discharge volume of refrigerant gas increases, resulting in the increase of refrigeration capacity. However, when any one of the step (3-stage / 4-stage) capacity control solenoid valves is energized, the high-pressure oil in the piston

cylinder bypasses to the suction side, causing the piston and slide valve to move to the left and part of the refrigerant gas bypasses the suction port from the compression chamber. At this time, due to the reduction of refrigerant discharge, resulting in the reduction of refrigeration capacity. The piston spring is used to push the piston back to its starting position. If the compressor is started under full load, it will generate over-current start-up. Therefore, in order to reduce the start-up current of the next start-up, the slide valve should be unloaded to the minimum load position during shutdown.

3.2.13 or 4 Step Capacity control system

The compressor is equipped with two solenoid valves (RC2-100, RC2-140 and RC2-180) or three solenoid valves (other models). They can control the capacity of the compressor from the minimum capacity to the full load state (100%). These two / three normally closed (NC) solenoid valves are used to control the required capacity. When the compressor with a 3 / 4 step capacity control system, the compressor is loaded through 33% - 66% to 100% or 25% - 50% - 75% to 100% process, and the compressor is unloaded through 100% - 66% - 33% or 100% - 75% - 50% to 25% process. If needs to operate under 25% loading for long time, oil return, motor cooling and high discharge temperature should be considered. For example, the motor is cooled by liquid injection and the lubricating oil is cooled by external oil circuit.

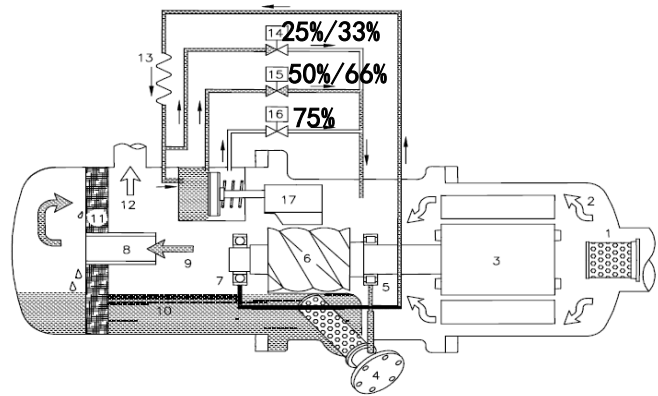

Figure 3-3 (3&4 step) Capacity control

No.	Part Name	No.	Part Name
1	Suction filter	10	Lubricating oil
2	Suction gas	11	Oil separator filter
3	Motor	12	Discharge gas
4	Oil filter	13	Capillary
5	Suction bearing	14	Solenoid valve (25%/33%)
6	Male rotor	15	Solenoid valve (50%/66%)
7	Discharge bearing	16	Solenoid valve (75%)
8	Muffler tube	17	Sliding valve
9	Discharge gas	*	RC2 -100~180 only with 33%/66%

3.2.1.1 25% (33%) loading

When the compressor starts, the solenoid valve is activated, and the piston is in the 25% (33%) load position. In this state, the high-pressure oil from the oil tank is continuously injected into the piston cylinder through the capillary, and the high-pressure oil in the piston cylinder is directly bypassed to the suction port, so the piston remains in its initial position.

RC2 -100、 140、 180	33% (NC)	66% (NC)	
100% loading	N	N	
66% loading	N	Y	
33% loading (Start/ Stop)	Y	N	
RC2 -200~1530	25% (NC)	50% (NC)	75% (NC)
100% loading	N	N	N
75% loading	N	N	Y
50% loading	N	Y	N
25% loading (Start/ Stop)	Y	N	N

⚠ Note: Activate the SV1 (25%) for 1 ~ 3 minutes before starting the compressor, so that the sliding valve is at the minimum load before start-up, so as to avoid the trip protection caused by large current when the motor is started. After the start-up process, do not run the compressor for a long time under 25% load, but directly load the compressor (especially in the case of large differential pressure / pressure ratio) to prevent the compressor discharge temperature from being too high.

3.2.1.2 50% (66%) loading

When the 50% / 66% solenoid valve is activated, the high-pressure oil from the oil tank flows into the piston cylinder and pushes the piston to move to the right. When it moves to 50% / 66%, the high-pressure oil flows back from the oil unloading hole to the suction port through 50% / 66%, so the piston stops running at this position and the compressor remains at 50% / 66% load state.

3.2.1.3 75% loading (RC2 -100~RC2 -180 without this loading state)

When 75% solenoid is activated, and the 50% solenoid valve is off, the high oil pressure pushes the piston to move to the right. When the valve moves to 75%, the high pressure oil flows back to the suction port through 75% of the oil hole, so the piston stops running in this position and the compressor is kept at 75% load state.

3.2.1.4 100% loading

When all the solenoid valves are off, the high oil pressure continuously flows into the piston cylinder and gradually pushes the piston to move to the suction side. When the sliding valve contacts the dead center of the compression chamber, the piston also reaches its dead center position. At this time, there is no compressed gas bypass, the compressor reaches full load.

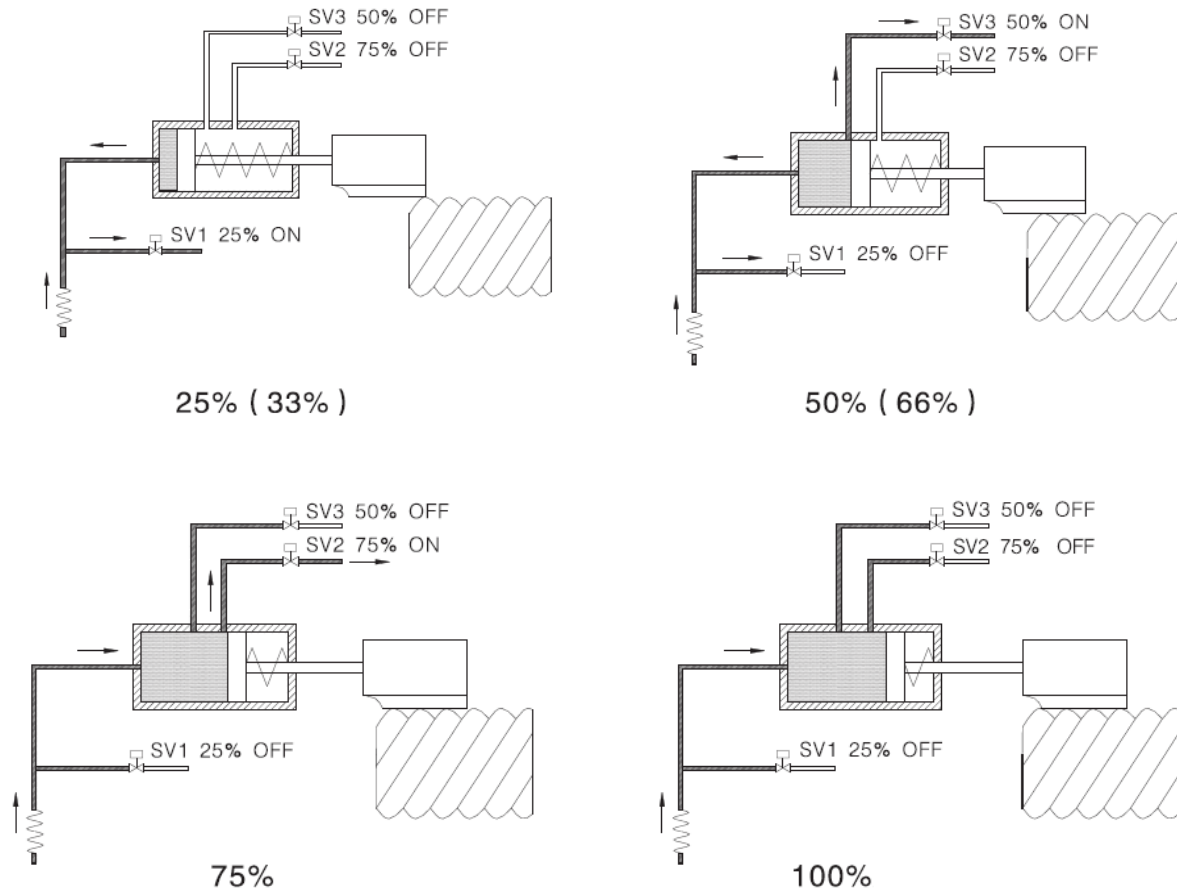

Figure 3-4 25% 、 50%、 75%、 100% Loading schematic diagram

©Note: ON: the solenoid valve is activated; OFF: the solenoid valve is not activated

3.2.2 Continuous loading of compressor

Since it will take a long time for compressor to reach the required working conditions, the compressor shall be started at 25% or 33% loading and kept for about 30 seconds (the startup time length recommended by Hanbell). Then the compressor is gradually loaded to 50% (66%) in time "t" and then loaded to 75% in another "t" time. The time "t" is determined according to different working conditions and application conditions.

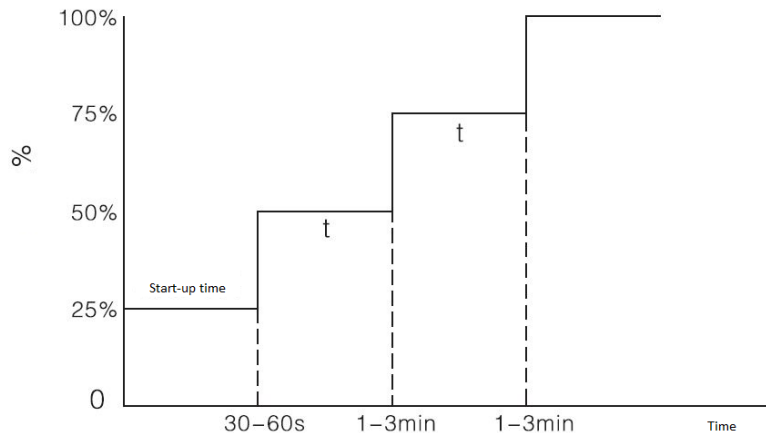

Figure 3-5 Continuous loading time chart of compressor

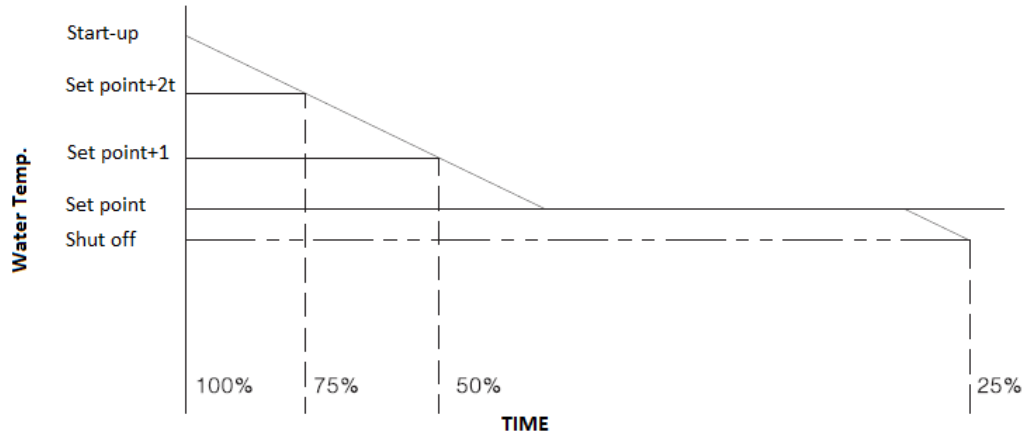

Figure 3-6 Diagram of outlet water temperature and capacity control

Please refer to the chapter of capacity control system for specific information. If you need special capacity control system, please contact Hanbell directly.

4. Electrical parameters and design

4.1 Start-up

The standard startup mode of Hanbell RC2-D series screw compressor is Y-Δ startup.

1) Y-Δ start-up

Y-Δ connection mode is Y shape connection when start-up. At this time, the voltage on the winding is reduced to 1/3 of the input voltage. After the start-up, re-connect to the delta shape. By this starting model, we can reduce the starting current by the reducing the starting voltage, which is also called step-down start.

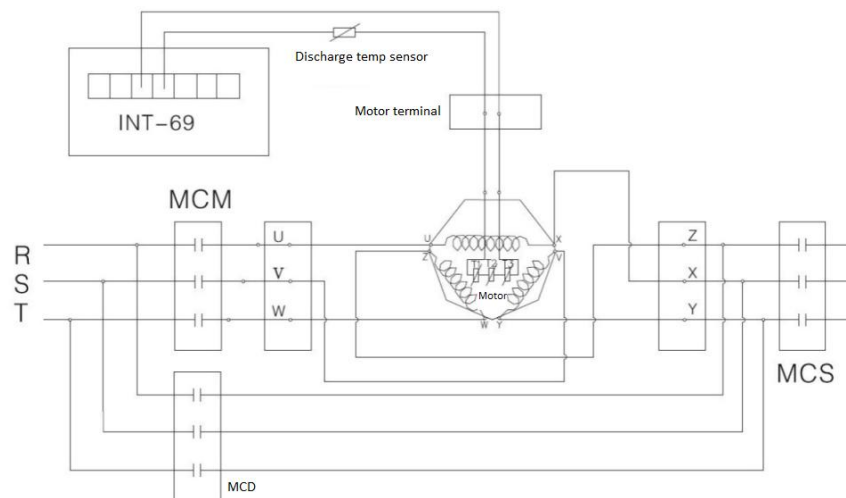

Figure 4-1 Y-Δ Connection diagram

⚠ Note: After the Y - shape startup, the MCM & MCS conversion takes 0.25 seconds, and the MCM & MCD gets the power to conduct the delta operation. In 0.25 seconds, it may cause pseudo short circuit due to improper contactor action, resulting in compressor jumping. When this happens, it is recommended to use an adjustable Y- Δ time relay or delay device to extend the conversion of MCM and MCD, and the power gain time is about 0.25 to 0.5 seconds. Please refer to the Y- Δ Conversion Time Diagram for specific information.

In Y-connection, MCM and MCS are electrified to make Z, X and Y become the center of Y connection. After a few seconds (3-5 seconds recommended), the MCM and MCS are disconnected. After about 0.25 seconds, the MCM and MCD are powered on, and at this time, they are converted to Δ shape connection. Y- Δ conversion time diagram is shown in Figure 4-2.

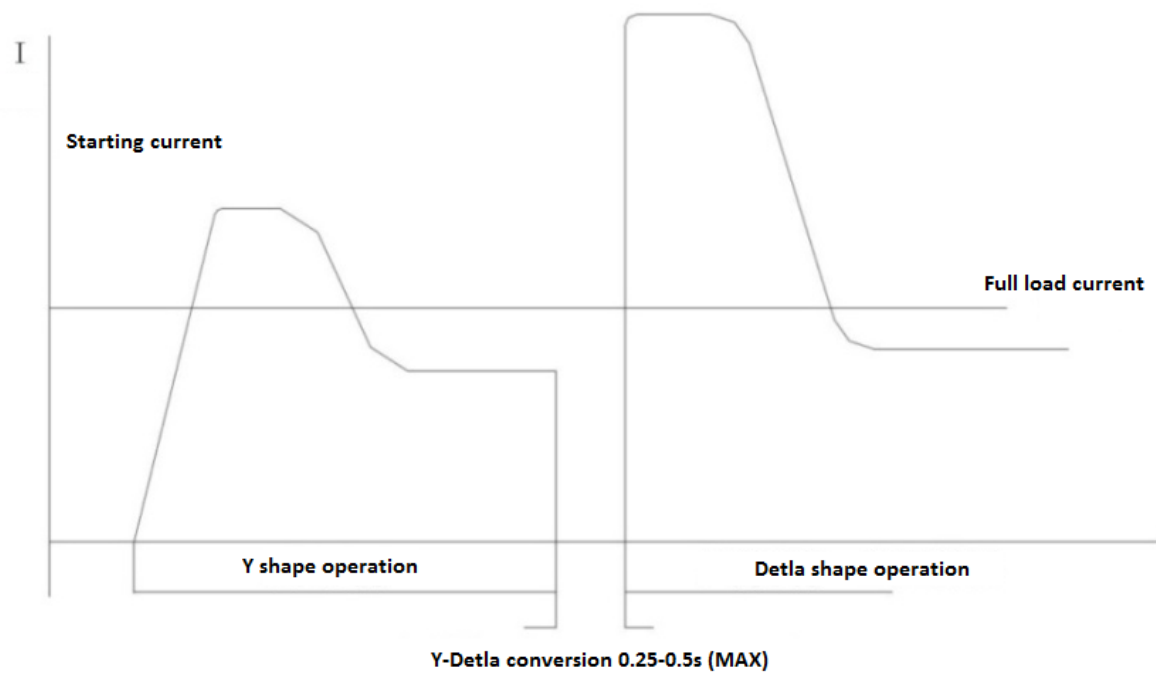

Figure 4-2 Y-Δ conversion time diagram

2) Y-Δ startup features

- The starting current of Y shape connection is 1/3 of the locked rotor ampere. The starting torque of Y shape connection is 1/3 of the locked rotor torque.
- The rotating acceleration of the electrode is reduced when the overload starts, so the compressor needs to start with light load.

Note: In addition to Y-Δ startup, if there is a need of soft start or reactance step-down start, please contact Hanbell for further information.

4.2 Start-up limit

Hanbell compressor is started by Y-Delta, and the compressor must be at the lowest load when starting.

1) Compressor start-up

- RC2-100D~580D compressor should not start more than 6 times per hour, and RC2-620D~930D compressor should not start more than 4 times per hour.
- When starting, the compressor should be at the lowest load (25% or 33%).
- In case of low ambient temperature, the oil heater must be powered on and heated 6 hours before the compressor start to maintain the oil temperature.
- When starting, Y connection time is generally 4 ± 1 s, and the max allowable time of Y switching to Δ connection is 40ms. The actual Y-Δ conversion time can be adjusted according to the actual working conditions on site, the longest Y-Δ conversion time is no more than 7 seconds.
- When starting, the power supply voltage shall not exceed $\pm 10\%$ of the rated voltage.

2) Power limit

- Long-term operation: Rated voltage $\pm 5\%$.

- Instantaneous operation: Rated voltage $\pm 10\%$.
- Frequency: Rated frequency $\pm 2\%$.
- Unbalanced voltage of each phase: $\pm 1\%$.

Note: An additional high&low voltage protector shall be set up in the unstable voltage area. Setting the rated voltage within the range of $\pm 5\%$ can ensure the safe and long-term operation of the compressor.

3) Unbalanced voltage

Voltage unbalance is usually caused by load change. When the load of each phase is different, voltage unbalance will appear which may cause serious damage to the motor. NEMA is defined as voltage unbalance as follows:

$$\text{Voltage unbalance} = \frac{\text{Difference between average voltage and maximum voltage in three phase voltage}}{\text{Average voltage}} * 100\%$$

✧ According to NEMA, the best operation condition of multiphase motor is that the voltage unbalance of motor is not more than 1%. In addition, it is recommended not to start the motor when the voltage imbalance exceeds 5%, which may cause serious damage to the motor.

4) Contactor selection

Please select the appropriate contactor according to AC3 specification, compressor selection program and system design status.

5) Grounding requirements

There is a grounding connector in the wire box, please connect it to the grounding terminal of the system control panel accurately.

⚠ Note:

- A.** The setting value of normal leakage protector should be higher than 50mA; In humid environment, 25mA is better.
- B.** The grounding voltage shall not exceed 50V; not exceed 25V in humid environment
- C.** The grounding resistance should not exceed 500Ω.
- D.** Air circuit breaker is usually equipped with electronic leakage protection; please refer to the relevant settings to ensure its normal operation.
- E.** If the electronic leakage protector alarm, please check whether the insulation device is normal and whether its circuit and setting are correct. Please make sure there is no error before turning on the power. If there is any problem, please contact the equipment supplier.

4.3 MCC&LRA

Starting current definition (LRA): add rated frequency, and rated voltage to the motor coil, block or restrain the motor rotors so that the motor cannot rotate, the current of the motor at this time is called the starting current (also known as locked rotor ampere).

Maximum operating current definition (MCC): maximum load current of compressor motor running.

Motor: Mainly used for R22, R404A, and R507 refrigerant

Frequency: 50Hz; Voltage: 380V			Frequency: 50Hz; Voltage: 380V		
Model	MCC(A)	LRA(A)	Model	MCC(A)	LRA(A)
RC2-100D-S(P)	55	245	RC2-410D-S(P)	208	740
RC2-140D-S(P)	72	330	RC2-470D-S(P)	245	840
RC2-180D-S(P)	91	490	RC2-510D-S(P)	250	840
RC2-200D-S(P)	99	490	RC2-550D-S(P)	280	925
RC2-230D-S(P)	119	510	RC2-580D-S(P)	300	925
RC2-260D-S(P)	129	510	RC2-620D-S(P)	317	1295
RC2-300D-S(P)	148	645	RC2-710D-S(P)	360	1410
RC2-310D-S(P)	157	645	RC2-790D-S(P)	382	1510
RC2-340D-S(P)	174	730	RC2-830D-S(P)	429	1640
RC2-370D-S(P)	188	780	RC2-930D-S(P)	491	2090

Table 4-1 RC2-D series compressor MCC&LRA

Note: MCC in table 4-1 above will vary depending on voltage and frequency.

4.4 Wiring diagram of terminal cover plate

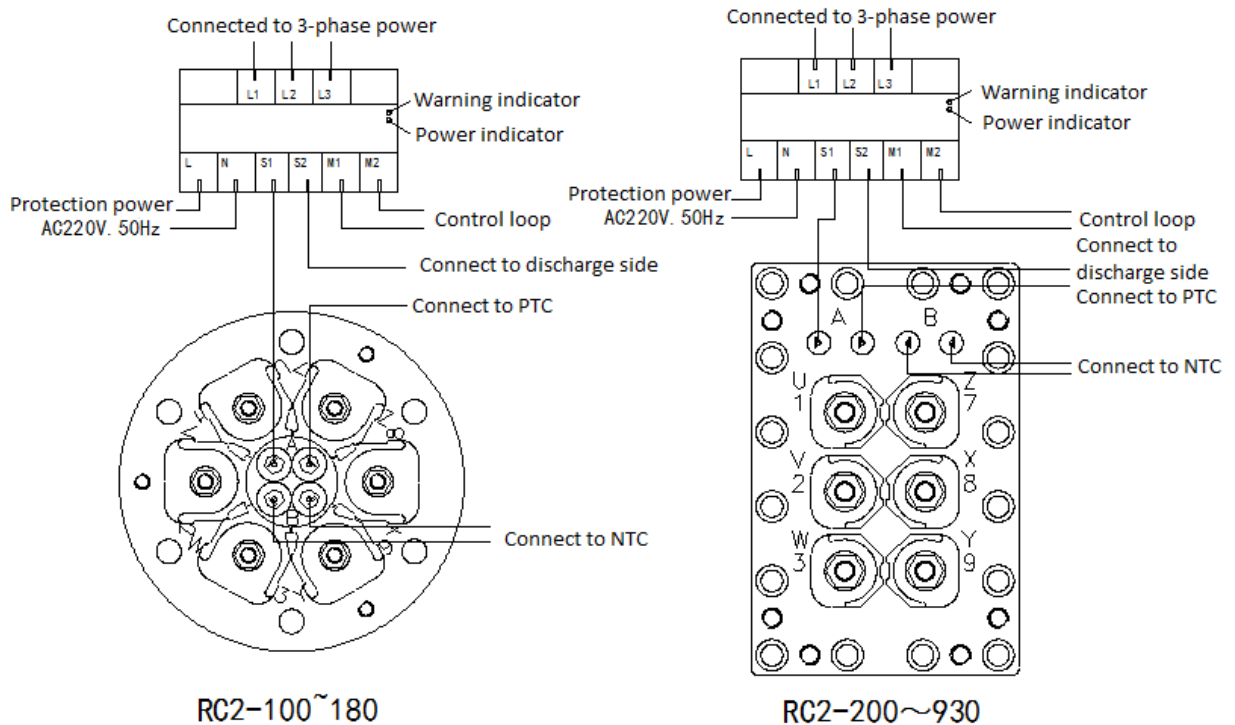

4.5 Grounding

There is a ground wire connector in the terminal box. Please make sure it is connected with the ground wire.

Note:

- a. The setting of leakage protector should be more than 50mA; In humid area, the setting should be changed to 25mA

- b. The grounding voltage of terminal box shall not be greater than 50V; in humid area, it should be 25V.
- c. The grounding resistance shall not be greater than 50Ω.
- d. Air cut board (ACB) is usually connected with leakage protector. Please refer to relevant operation settings.
- e. Once the leakage protection is started, please check if the insulation is normal and if the circuit and setting are correct. Please turn on the power after confirmation. If you have any questions, please contact the equipment supplier.

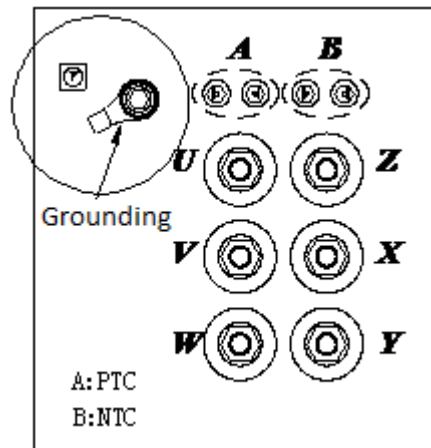
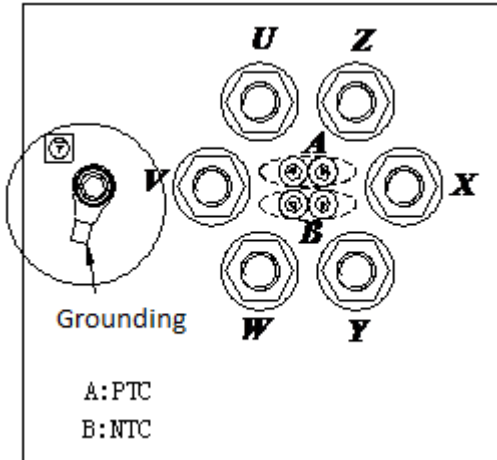

Specification for terminal plate nut		
Model	Specification	Torque(N.m)
RC2 -100~180D-S(P)	M8	20
RC2 -200~930D-S(P)	M12	35

Note: when the surface temperature of compressor is lower than the air dew point temperature, it is recommended to wrap the exposed part of the wiring with electrical insulation tape to improve reliability

5. Accessories

In order to provide customers with an overall solution, Hanbell design standard accessories and optional accessories according to different application requirements, to ensure that the compressor can be safe, stable operation, and achieve the highest efficiency.

5.1 Standard Accessories and Optional Accessories

Accessories list		●	Standard	
		△	Optional	
Item	Part name	Qty	Parallel application	Single application
1	Discharge stop valve	1	●	●
2	Discharge check valve	1	●	●
3	Suction stop valve	1	●	●
4	Suction check valve	1	△	△
5	ECO stop valve	1	●	●
6	Liquid injection controller	1	△	△
7	Suction& discharge bushing	1 set	●	●
8	Damping pad	4	●	●
9	Oil circuit solenoid valve	1	●	△
10	External oil filter	1	●	△
11	Oil flow switch	1	●	△
12	Oil sight glass	1	●	△
13	External oil filter differential pressure monitoring switch	1	●	●
14	Protection module	1	●	●
15	Discharge temp sensor	1	●	●
16	Motor coil temp sensor	1	●	●
17	Oil level switch	/	△	●
18	Pressure maintaining valve and bushing	1 set	△	△
19	Lubricating oil	/	△	●
20	300W Oil heater	1	△	●

5.2 Accessories Introduction

Hanbel compressor is equipped with a series of accessories; the following are described in details.

5.2.1 Suction & Discharge bushing

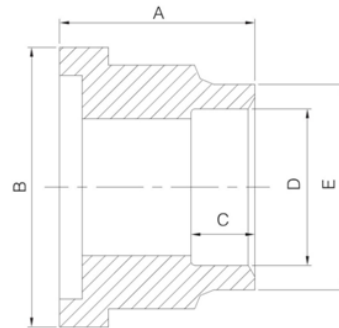

RC2-100~930D-S suction and discharge flange, bushing configuration								
Model& Flange	Size	Material& Size		Dimension				
				φA	φB	φC	φD	φE
RC2-100~RC2-200 Discharge flange	1-1/2"	Copper	1- 5/8"	52	75	35	42	52
		Steel	1- 1/2"				49.3	64
RC2-100, RC2-140 Suction flange RC2-230~RC2-310 Discharge flange	2"	Copper	2- 1/8"	50	90	30	55	65
		Steel	2"				61.3	74
RC2-180, RC2-200 Suction flange RC2-340~RC2-470 Discharge flange	2-1/2"	Copper	2- 5/8"	60	110	35	68	77
		Steel	2- 1/2"				77.2	90
RC2-230~RC2-310 Suction flange RC2-510~RC2-620 Discharge flange	3"	Copper	3- 1/8"	66	120	45	80.5	90
		Steel	3"				90.2	103
RC2-340~RC2-580 Suction flange RC2-710~RC2-930 Discharge flange	4"	Copper	3- 5/8"	76	145	50	93	103
		Steel	4"				110	128
RC2-620~RC2-930 Suction flange	5"	Copper	4- 1/8"	80	174	35	106	121
		Steel	5"	75			135	154

Note: The above specification is for standard RC2-D series compressor (D-S type), If need non-standard bushing, please confirm with hanbell.

RC2-100~930D-P suction and discharge flange, bushing configuration								
Model& Flange	Size	Material& Size		Dimension				
				A	B	C	D	E
RC2-100, RC2-140 Suction flange RC2-100 ~ RC2-200 Discharge flange	2"	Copper	2- 1/8"	50	90	30	55	65
		Steel	2"				61.3	74
RC2-180, RC2-200 Suction flange RC2-230 ~ RC2-370 Discharge flange	2-1/2"	Copper	2- 5/8"	60	110	35	68	77
		Steel	2- 1/2"				77.2	90
RC2-230~RC2-310 Suction flange RC2-410 ~ RC2-580 Discharge flange	3"	Copper	3- 1/8"	66	120	45	80.5	90
		Steel	3"				90.2	103
RC2-340~RC2-580 Suction flange RC2-620 ~ RC2-930 Discharge flange	4"	Copper	3- 5/8"	76	145	50	93	103
		Steel	4"				110	128
RC2-620~RC2-930 Suction flange	5"	Copper	4- 1/8"	80	174	35	106	121
		Steel	5"	75			135	154

Note: The above specification is for standard RC2-D series compressor (D-P type), If need non-standard bushing, please confirm with hanbell.

5.2.2 Suction & Discharge stop valve

In order to facilitate the maintenance and repair of the compressor, it is recommended to install the suction and discharge stop valve. Please refer to the following table for the Hanbell shutoff valves.

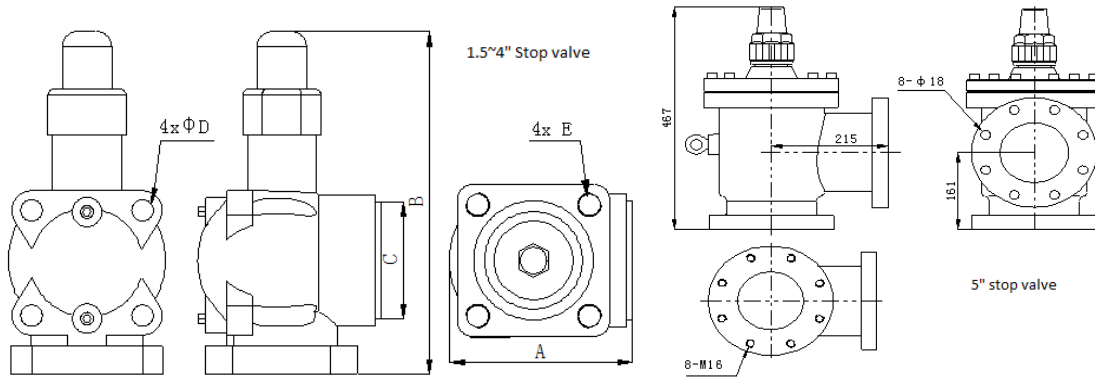

Spec.	Dimension					Max working pressure
	A	B	φC	φD	E	
1-1/2"	115	263	75	18	M16X2	28 Bar
2"	131	284	90	18	M16X2	
2-1/2"	147	289	110	18	M16X2	
3"	177	351	120	22	M20X2.5	
4"	209	407	145	22	M20X2.5	

D-S Type					
Model	Suction	Discharge	Model	Suction	Discharge
RC2-100	2"	1-1/2"	RC2-410	4"	2-1/2"
RC2-140	2"	1-1/2"	RC2-470	4"	2-1/2"
RC2-180	2-1/2"	1-1/2"	RC2-510	4"	3"
RC2-200	2-1/2"	1-1/2"	RC2-550	4"	3"
RC2-230	3"	2"	RC2-580	4"	3"
RC2-260	3"	2"	RC2-620	5"	3"
RC2-300	3"	2"	RC2-710	5"	4"
RC2-310	3"	2"	RC2-790	5"	4"
RC2-340	4"	2-1/2"	RC2-830	5"	4"
RC2-370	4"	2-1/2"	RC2-930	5"	4"

D-P type					
Model	Suction	Discharge	Model	Suction	Discharge
RC2-100	2"	2"	RC2-410	4"	3"
RC2-140	2"	2"	RC2-470	4"	3"
RC2-180	2-1/2"	2"	RC2-510	4"	3"
RC2-200	2-1/2"	2"	RC2-550	4"	3"
RC2-230	3"	2-1/2"	RC2-580	4"	3"
RC2-260	3"	2-1/2"	RC2-620	5"	4"
RC2-300	3"	2-1/2"	RC2-710	5"	4"
RC2-310	3"	2-1/2"	RC2-790	5"	4"
RC2-340	4"	2-1/2"	RC2-830	5"	4"
RC2-370	4"	2-1/2"	RC2-930	5"	4"

5.2.3 Suction check valve

Check valve is a kind of valve which can automatically prevent the backflow of fluid. The disc of the check valve opens under the action of fluid pressure, and the fluid flows from the inlet side to the outlet side.

When the pressure on the inlet side is lower than that on the outlet side, the valve disc will automatically close under the action of fluid pressure difference to prevent fluid backflow.

Specification	Dimension			Nut	Max working pressure
	A	B	C		
2"	φ90	85	φ102	M16*200	28bar
2-1/2"	φ110	97	φ122	M16*230	
3"	φ120	108	φ138	M20*280	
4"	φ145	123	φ163	M20*320	

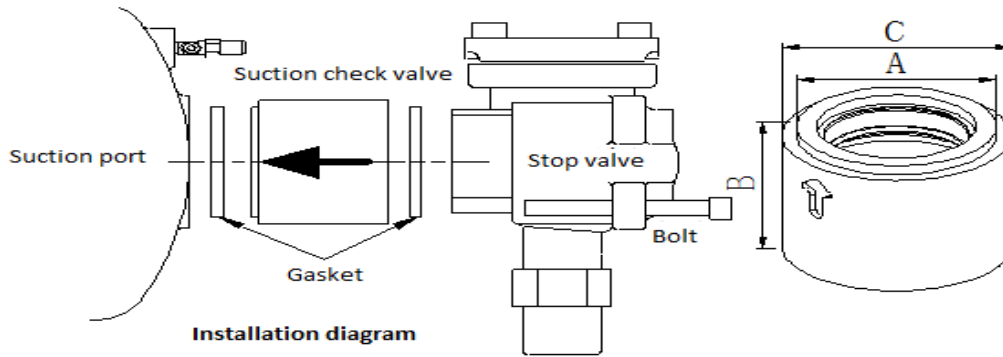

5.2.4 Horizontal discharge check valve

The horizontal discharge check valve is a standard accessory of RC2 - DP compressor. Considering the limited installation space, horizontal discharge check valve can replace gravity check valve for RC2 - DP compressor. The specification and installation diagram of horizontal check valve are as follows:

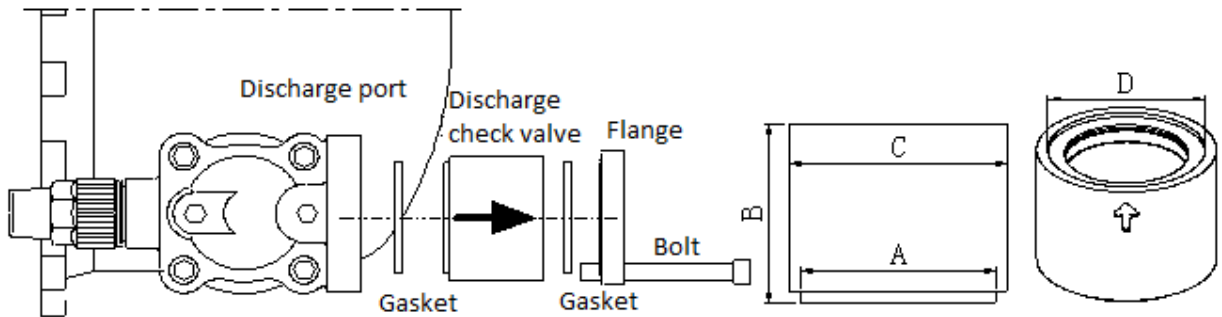

Specification	Dimension Unit:mm					Max working pressure
	ϕA	B	ϕC	ϕD	Nut	
2"	90	85	102	91	16*140	28 Bar
2-1/2"	110	97	122	111	16*150	
3"	120	109	138	121	20*170	
4"	145	125	163	146	20*190	
5"	175	150	203	176	M20*200	

5.2.5 Gravity check valve

Gravity check valve can automatically prevent the backflow of fluid. The valve disc opens under the action of fluid pressure, and the fluid flows from the inlet side to the outlet side. When the pressure at the inlet side is lower than that at the outlet side, the valve disc will automatically close under the action of fluid pressure difference, gravity and other factors to prevent fluid backflow.

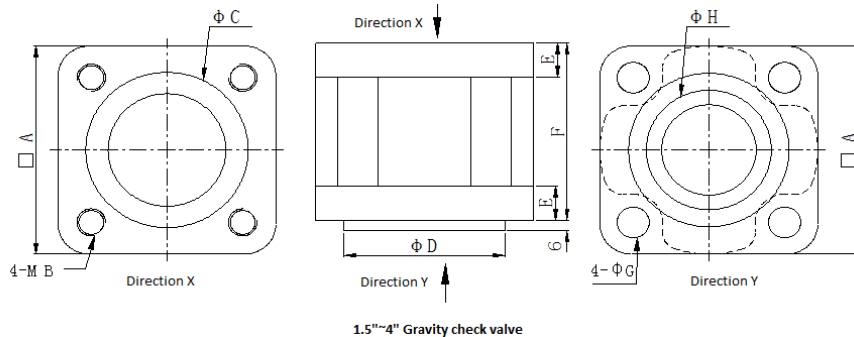

Size	A	B	C	D	E	F	G	H	Max working pressure
1.5"	109	16	76	75	20	99	18	60	28 Bar
2"	122	16	91	90	20	104	18	70	
2.5"	134	16	111	110	25	119	18	90	
3"	153	20	121	120	25	129	22	100	
4"	171	20	146	145	25	129	22	125	

5.2.6 Economizer stop valve

Economical stop valve for RC2-D is optional. The specific type and installation are as follows:

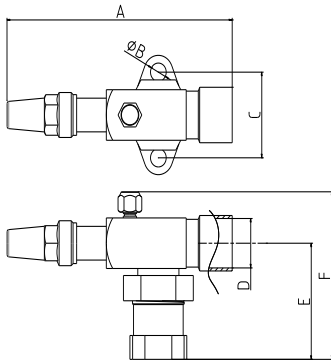

Size	A	B	C	D	E	F	Model
7/8	131.5	11	46	22.3	89.3	124	RC2-100~RC2-180D-S/P
7/8	131.5	11	46	22.3	76.3	111	RC2-200~RC2-260D-S/P
1 1/8	138.5	13	54	28.2	76.8	111	RC2-300~RC2-510D-S/P
1 3/8	186	13	61	35.2	82.7	119	RC2-550~RC2-710 D-S/P
1 3/8	186	13	61	35.2	96.3	133	RC2-790~RC2-930D-S/P

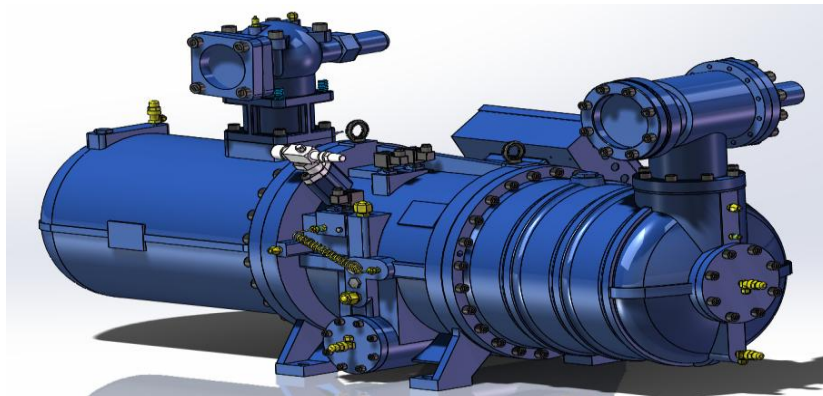

Installation diagram

5.2.7 Pressure maintaining valve

The pressure maintaining valve enables the compressor to quickly establish enough high and low pressure difference within a short period of time after starting up, so as to ensure the smooth loading of the compressor and ensure that the compressor will not be adversely affected by oil loss.

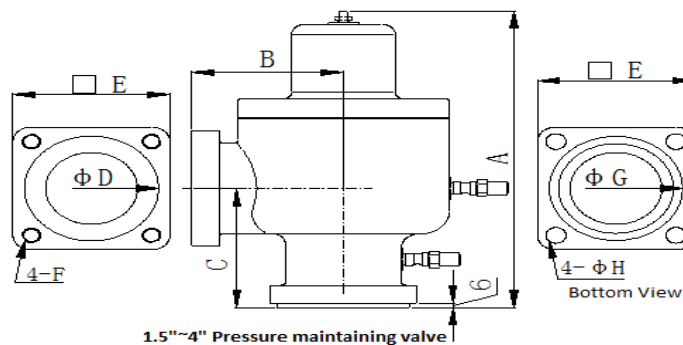

Size	A	B	C	D	E	F	G	H	Pressure loss	Max working pressure	Opening pressure difference
1.5"	235	93	119	76	109	M16	75	18	<0.1 Bar	30 Bar	3.6 ±0.3 Bar
2"	247	105	126	91	122	M16	90	18			
2.5"	300	110	136	111	134	M16	110	18			
3"	364	122	156	121	153	M20	120	22			
4"	413	165	166	146	171	M20	145	22			

5.2.8 Protection Module

5.2.8.1 INT69 HBY Diagnose protection module

Application:

The protection module INT69 HBY Diagnose is the advanced product of the protection module series, which is used for the compressor protection microcontrollers. The flexible response function is added in the phase sequence monitoring, which improves the practicability and prolongs the life of the refrigeration system. INT69 HBY Diagnose automatically stores work and error data in a memory. Only through a specific transmission line, the data can be read on a personal computer and be used for diagnostic analysis.

Function:

- The PTC thermistor in series enters the signal input end of the protection module.
- If any resistance value of the thermistors rises above the jump off value, the protection module will jump off. The blocking value of PTC will reduce to the reset value. After 5 minutes of reset time, the module will automatically reset. In the first disconnected 24 hours, if the PTC values rise to the reset value again, the reset time will be 60 minutes. If the PTC third time rise to the reset value in 24 hours, the module will be locked and cannot be reset automatically.
- One second after the motor starts, the motor phase monitoring function will be activated and remain to be activated for 5 seconds. Motor phase being abnormal or motor being under-phase will cause the protection module to be disconnected and locked.
- In order to avoid the tripping caused by reversal after the compressor shutdown, the phase monitoring function will only maintain for 20 seconds after the motor is stopped.
- LED (Red / Green / Orange) shows its working information.
- The motor protection module cannot be used in the variable frequency drive device.
- The PTC short circuit will cause deadlock, and the short cycle will lead to the reset delay.
- If the reset delays when the temperature reduces or the error is removed, please reset the module.

The compressor needs to be restarted after the reset.

- ⚠ This module must be assembled and maintained by a professional electrician. It should have European or national standards. When the module is connected to electrical equipment and cooling devices the connection line between the terminal box and the temperature sensor must be the insulation line.

Technical data:

Item	Technical data	Item	Technical data
Supply voltage	AC 50/60HZ 115/240V±10% 3VA	System PTC short circuit monitoring	Normally <30Ω
Motor voltage	3 AC 50/60Hz 200/690V ±10%	Over frequency operation	Not support
— Sensor type — R25, All — Maximum connection length	Connect 1-2 AMS sensors and 1-9 PTC in serial as optional; serial connection shall meet the DIN 44081 and DIN 44082 standards. <1.8KΩ 30M	— Motor static jump off 1 times/24h 2 times/24h 3times/24h — Switching frequency — Phase stagger — Phase loss Cancel deadlock or reset delay	5min±1min 60min±12min Deadlock 5min±1min Deadlock Deadlock Power off and reset
Ambient temperature	-30...70°C	Max switching frequency	Switch for 3 times within 30s
Phase monitor — Phase sequence — Phase loss — Inactivation	Activated 1 second after the motor starts and will remain monitoring for 5 seconds; Activated 1 second after the motor starts and will remain monitoring till the machine stops; About 20 seconds after the motor stops.	Delay reset relay — Power — Mechanical lifetime	AC 240V 2.5A C300 at least AC/DC 24V 20mA One million times on and off switching

Signal light flashing:

The signal light is for convenient, fast and easy maintenance; the signal is composed of red and orange.

The current state of light flashing depends on the number of pulse flashes.

Signal is as below:

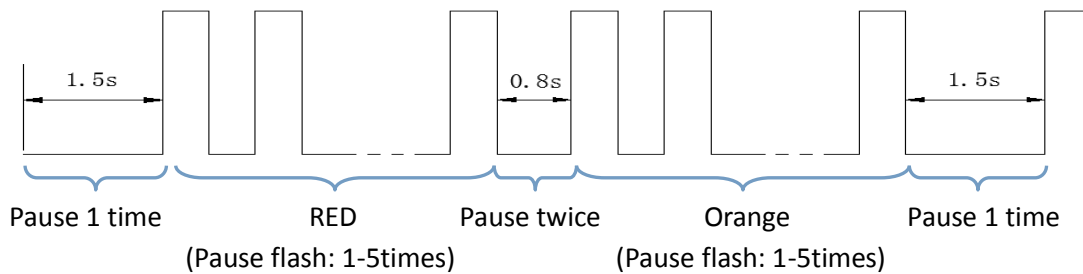

Description	Green	Compressor on standby
	Green flash	Compressor operation
	Red/ Organ flash	Faults occur; relay jump off; compressor stop; please refer to sticker to solve the faults.

Appearance and wiring:

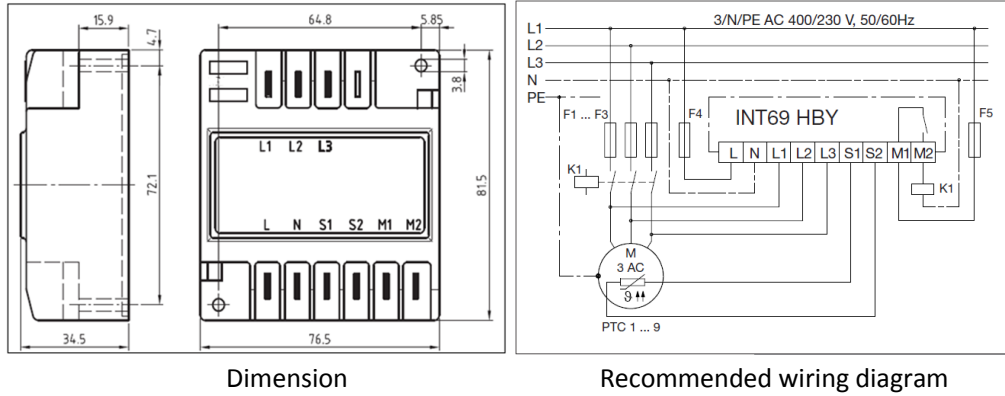

Note: The above figure only indicates the connection method of protection module; it is not the compressor startup mode.

Sticker:

INT69HBY Diagnose 接线图
INT69HBY Diagnose connection diagram

表示PTC传感器超过它的反应温度
indicates PTC sensor exceeds its response temperature

继电器输出
Relay Output

供给电源
Power Supply

电机电源
Motor Power

油温PTC(可选)
Oil Temp PTC (option)

排气温度PTC
Discharge Temp PTC

A: 电机PTC组终端
A Set: Motor PTC Terminal

INT69HBY Diagnose protector Simple troubleshooting	
Fault	Troubleshooting
Red flash 3; Orange flash 1	The voltage is too low Demand voltage: 115v-240v ± 10%
Red flash 2; Orange flash 1	Confirm if the power phase sequence is correct
Red flash 2; Orange flash 2	1. Measure if the 3-phase unbalance rate is less than 15%. 2. Check if the power is out of phase or poor contact.
Green light on, fail to start	Measure the resistance conduction between M1-M2, if M1-M2 is not connected, replace the protector
Red flash 1; Orange flash 1	Confirm if the temperature is too high; If not, start the compressor after automatic delay reset. If manual reset is required, wait 5 min after red flash 1 and orange flash 3, then restart the compressor. (It will fail to reset red&orange flash 1)
Red flash 1; Orange flash 3	Reset delay after temperature protection
Red flash1; Orange flash 4	Check if the PTC terminals are in bad contact.
Under normal operation green light flashes. Rated voltage range: U _L N: AC 115V~240V±10% 50/60Hz U _L L ₁ L ₂ L ₃ : AC 200V~690V±10% 50/60Hz	

5.2.8.2 Check Chapter 8 for module troubleshooting

The protection module must be connected by professional electricians and must comply with the relevant electrical installation standards. The power distribution is not allowed to exceed the maximum supply voltage of the module.

5.2.9 NTC Temperature Sensor

NTC is one kind of embedded temperature sensor which is installed inside the motor coil. It is connected with the micro control system to display the temperature of the motor and set the alarm point and disconnection point to protect the compressor

NTC temperature sensor and resistance valve:

Empirical value formula: $R = 10 * e^{3435 * (\frac{1}{273+T} - \frac{1}{273+25})}$; 10 is the resistance valve when temperature comes to 25°C; R is the resistance valve when temperature is T.

Temp	Resistance valve			Temp	Resistance valve			Temp	Resistance valve		
	Max	Typical	Min		Max	Typical	Min		Max	Typical	Min
°C	KΩ	KΩ	KΩ	°C	KΩ	KΩ	KΩ	°C	KΩ	KΩ	KΩ
-10	43,52	42,47	41,43	31	8,11	8,01	7,92	72	2,15	2,10	2,05
-9	41,55	40,57	39,60	32	7,83	7,73	7,63	73	2,09	2,04	1,99
-8	39,69	38,77	37,86	33	7,55	7,45	7,36	74	2,03	1,98	1,93
-7	37,92	37,06	36,21	34	7,29	7,19	7,10	75	1,98	1,92	1,87
-6	36,25	35,44	34,64	35	7,04	6,94	6,85	76	1,92	1,87	1,82
-5	34,66	33,90	33,15	36	6,79	6,70	6,61	77	1,87	1,82	1,77
-4	33,15	32,44	31,73	37	6,56	6,47	6,37	78	1,81	1,77	1,72
-3	31,72	31,05	30,39	38	6,34	6,25	6,15	79	1,76	1,72	1,67
-2	30,36	29,73	29,11	39	6,12	6,03	5,94	80	1,72	1,67	1,62
-1	29,06	28,48	27,89	40	5,92	5,83	5,74	81	1,67	1,62	1,58
0	27,83	27,28	26,74	41	5,72	5,63	5,54	82	1,62	1,58	1,53
1	26,65	26,13	25,62	42	5,53	5,44	5,35	83	1,58	1,53	1,49
2	25,52	25,03	24,55	43	5,34	5,26	5,17	84	1,54	1,49	1,45
3	24,44	23,99	23,54	44	5,17	5,08	4,99	85	1,49	1,45	1,41
4	23,42	23,00	22,57	45	5,00	4,91	4,83	86	1,45	1,41	1,37
5	22,45	22,05	21,66	46	4,83	4,75	4,67	87	1,42	1,37	1,33
6	21,53	21,15	20,78	47	4,68	4,59	4,51	88	1,38	1,34	1,30
7	20,64	20,30	19,95	48	4,52	4,44	4,36	89	1,34	1,30	1,26
8	19,81	19,48	19,15	49	4,38	4,30	4,22	90	1,31	1,27	1,23
9	19,01	18,70	18,39	50	4,24	4,16	4,08	91	1,27	1,23	1,19
10	18,25	17,96	17,67	51	4,10	4,03	3,95	92	1,24	1,20	1,16
11	17,51	17,24	16,97	52	3,97	3,90	3,82	93	1,21	1,17	1,13
12	16,81	16,56	16,30	53	3,85	3,77	3,70	94	1,17	1,14	1,10
13	16,14	15,90	15,67	54	3,73	3,65	3,58	95	1,14	1,11	1,07
14	15,50	15,28	15,06	55	3,61	3,54	3,46	96	1,12	1,08	1,04
15	14,89	14,69	14,48	56	3,50	3,43	3,35	97	1,09	1,05	1,02
16	14,31	14,12	13,92	57	3,39	3,32	3,25	98	1,06	1,02	0,99
17	13,75	13,58	13,39	58	3,28	3,22	3,15	99	1,03	1,00	0,97
18	13,22	13,06	12,89	59	3,18	3,12	3,05	100	1,01	0,97	0,94
19	12,72	12,56	12,40	60	3,09	3,02	2,95	101	0,98	0,95	0,92
20	12,24	12,09	11,94	61	2,99	2,93	2,86	102	0,96	0,92	0,89
21	11,77	11,63	11,50	62	2,90	2,84	2,77	103	0,93	0,90	0,87
22	11,32	11,20	11,07	63	2,82	2,75	2,69	104	0,91	0,88	0,85
23	10,90	10,78	10,66	64	2,73	2,67	2,61	105	0,89	0,86	0,83
24	10,49	10,38	10,27	65	2,65	2,59	2,53	106	0,87	0,84	0,81
25	10,10	10,00	9,90	66	2,57	2,51	2,45	107	0,84	0,82	0,79
26	9,73	9,63	9,53	67	2,50	2,44	2,38	108	0,82	0,80	0,77
27	9,38	9,28	9,18	68	2,42	2,36	2,31	109	0,80	0,78	0,75
28	9,04	8,94	8,84	69	2,35	2,30	2,24	110	0,79	0,76	0,73
29	8,72	8,62	8,52	70	2,28	2,23	2,17				
30	8,41	8,31	8,21	71	2,22	2,16	2,11				

NTC sensor temperature and resistance valve 10K@25°C

Note: please contact Hanbell for other temperature display requirements

5.2.9.2 Liquid injection controller

The liquid injection controller transforms the thermocouple (NTC3435, R25 = 10K) into a 4 ~ 20mA output signal which is linear with the measured temperature. The digital LED displays the real-time temperature, and the temperature value of relay action is set by pressing the key.

Temperature¤t; 0~110°C=4~20Ma, <0°C=4mA, >110°C=20mA

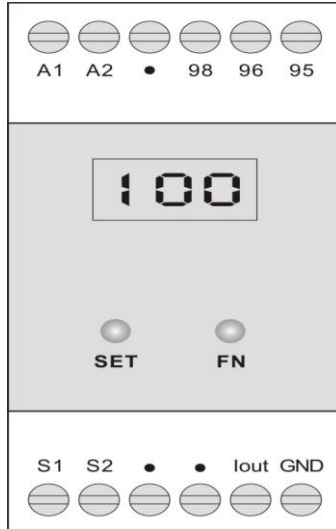

- ※ A1~A2 : Power AC90-265V 50/60Hz;
- ※ 95,96,98 : Common end, NC, NO;
- ※ S1~S2 : NTC-3435-10k;
- ※ Iout~GND : 4-20mA Output;

5.2.10 Oil heater – 300W

Each RC2-D compressor is equipped with 300W oil heater (parallel connection is optional). Please keep the oil heater on for more than 8 hours before the compressor starts up again after a long time shutdown, so

as to ensure that the internal temperature of the compressor is higher than the system temperature and ambient temperature, and avoid the poor lubrication effect caused by liquid compression or low viscosity of lubricating oil caused by the liquid refrigerant in the compressor oil tank.

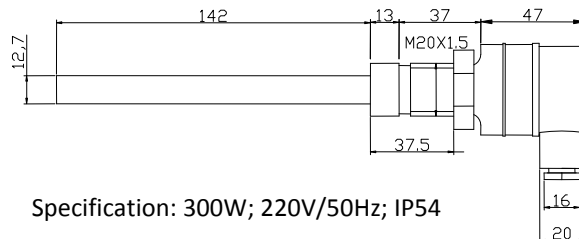

Specification: 300W; 220V/50Hz; IP54

5.2.11 Oil level switch

The oil level switch is equipped with two outgoing lines, which can be interlocked with the main control circuit or other micro controller circuits. In order to avoid the accidental tripping of the oil level switch due to the fluctuation of the oil in the oil tank, it is recommended to set the shutdown delay of 60-90 seconds

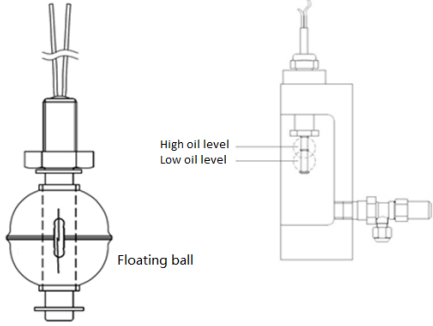

Technical data			
Contact capacity	50W/SPST	Switch action	N.O
Withstand voltage	240Vac/200Vdc	Operating pressure	50Bar
Max switching current	0.5A	Operating temp	-10°C~120°C
Max through current	1A	--	--

5.2.12 Oil Drain valve

The oil drain valve is used for oil discharge during the maintenance of the compressor.

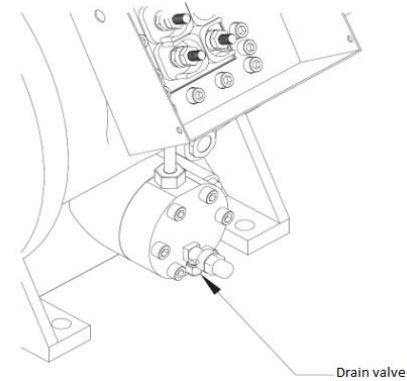

5.2.13 External oil filter pressure difference switch

The external oil filter pressure difference switch is used to detect the pressure difference before and after the oil filter, so as to prevent excessive foreign matters and impurities adsorbed on the surface of the oil filter screen from causing danger to the oil supply system.

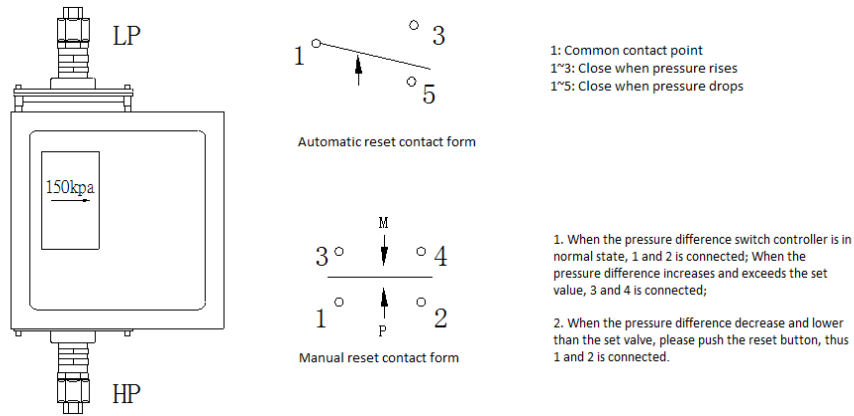
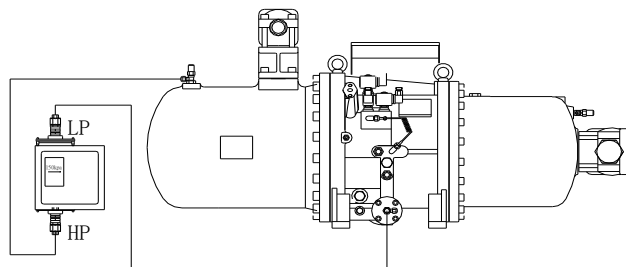

Figure- External oil filter pressure difference switch



Connection digram for External oil filter pressure difference switch

5.2.14 Muffler & Check valve for Ecocnimize

When using the economizer, it is recommended to install an economizer muffler before the medium

pressure gas return port of the compression chamber, and then install an economizer check valve to reduce the vibration caused by the medium pressure gas return. For the connection between muffler and check valve, please refer to the application system in Chapter 7.

5.2.15 External Oil filter

For parallel connection system, an external oil filter must be installed on the return line to ensure the cleanliness of the oil return. If the pipeline is too dirty, secondary filtration must be added to ensure the compressor is in safe operation. The oil filter is of washable type, with the precision of 300 meshes. See the following figure for the dimensions. The thread / welding ports of the inlet and outlet are connected with 3 / 8 ", 5 / 8" and 1 "copper pipes.

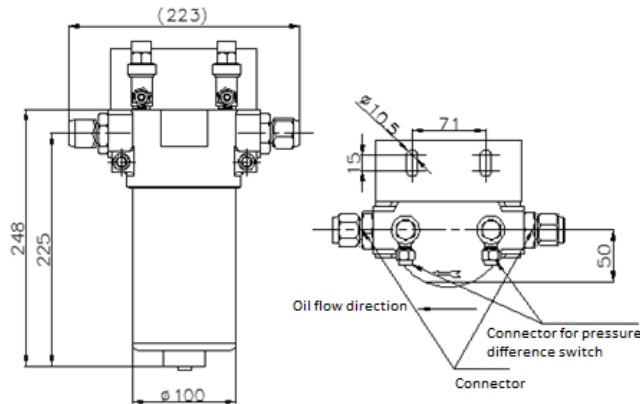

Size	Connection	Model
3/8"	Thread/Weld	RC2-100~180D-P
5/8"	Thread/Weld	RC2-200~620D-P
1"	Weld	RC2-710~930D-P

Figure-External Oil filter

5.2.16 Oil flow switch

The oil flow switch should be installed in the system with external oil separator to prevent oil loss of the compressor. The specifications and installation are as follows:

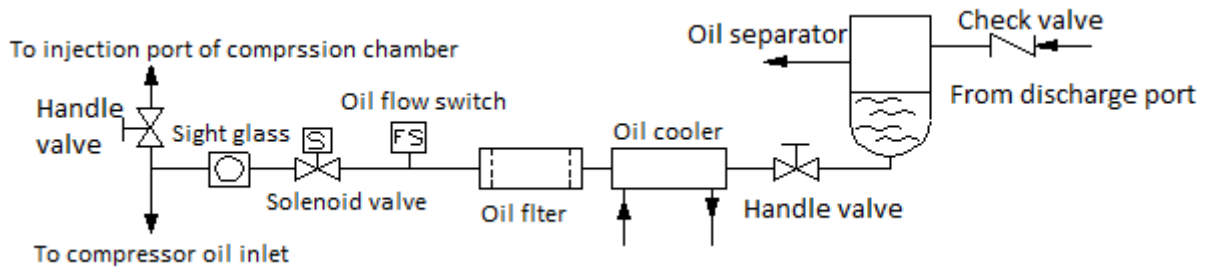

Installation diagram of oil flow switch

Type	Connection	Pipe size		Applicable model
		Thread	weld (d)	
138	Thread/weld	3/8"	Φ10	RC2-100~310D-P
138	Thread/weld	5/8"	Φ16	RC2-340~620D-P
138	Weld	1"	Φ25.5	RC2-710~930D-P

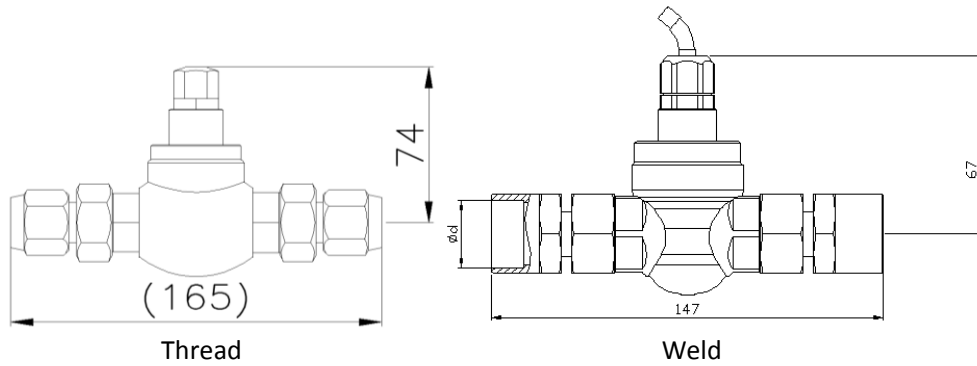
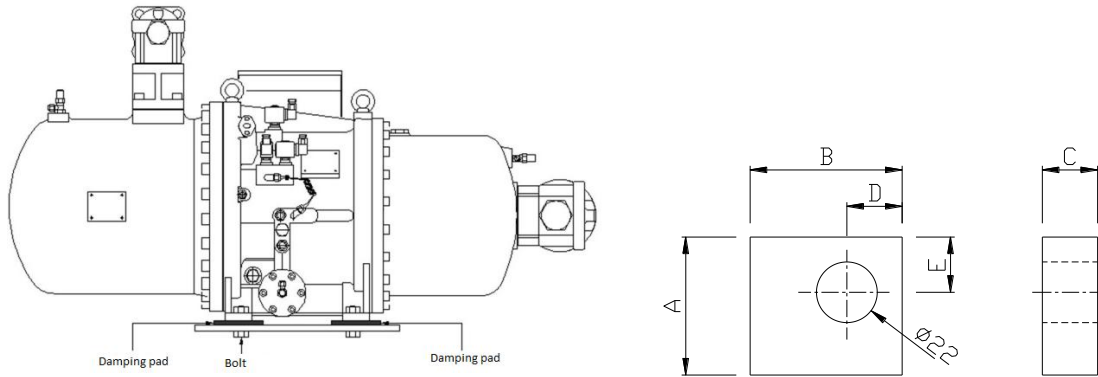

Figure- Oil flow switch

5.2.17 Damping pad

In order to avoid the vibration and noise caused by the direct contact between the compressor and its mounting foot and mounting base, it is recommended to install the damping pad at the position shown in the figure below. The installation torque requirement is 20 ~ 30n · M.



No.	A(mm)	B(mm)	C(mm)	D(mm)	E(mm)	Model
1	50	55	20	20	20	RC2-100~RC2-370
2	70	100	20	25	25	RC2-410~RC2-620
3	80	100	20	25	25	RC2-710~RC2-930

5.2.18 IP54 Terminal box

The terminal box reaches IP54 protection level. Please refer to the figure below to understand the external dimension and internal dimension.

1) RC2-100~180D-S(P) terminal box

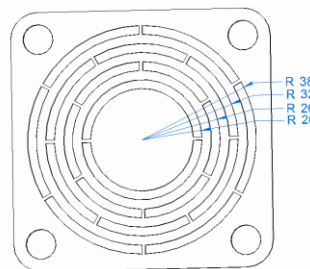
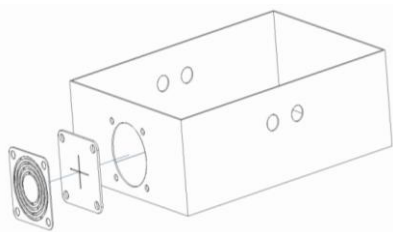

2) RC2-200~470 D-S(P) terminal box

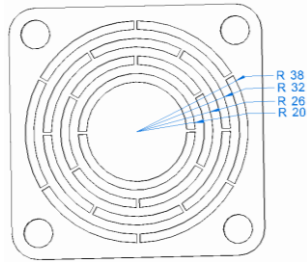
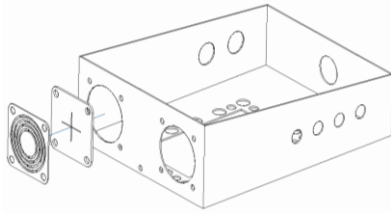

3) RC2-510~930 D-S(P) terminal box

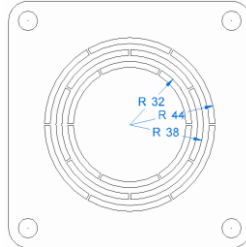
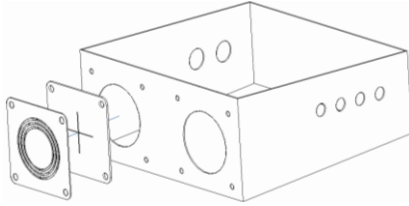

6. Lubricating oil

The main functions of lubricating oil are lubrication, cooling and capacity control. The oil pressure in the piston cylinder pushes the piston and slide valve forward and backward in the compression chamber. The differential pressure oil supply system in RC2-D series can replace the external oil pump. In some special applications, an external oil pump is still needed to ensure the safe operation.

The bearing of RC2-D series compressor only needs a small amount of oil for lubrication. The oil injected into the compression chamber can form an oil film in the compression chamber to increase the efficiency of the compressor and absorb part of the heat generated in the compression process.

During the operation, special attention should be paid to the temperature of lubricating oil, which is an important factor affecting the bearing life of compressor. High lubricating oil temperature will reduce the viscosity, resulting in the decrease of lubricating capacity and heat absorption capacity. It is recommended to keep the viscosity of the oil above 10mm²/s. When the ambient temperature is too high, the oil temperature should be kept above the condensation temperature of the system to avoid the migration of refrigerant into the system. When the ambient temperature is too low, the viscosity of the lubricating oil is high, and the pressure drop in the oil circuit is too large to load normally, which leads to the heavy load start. Therefore, an oil heater is needed to heat the lubricating oil to improve the oil temperature in a short time.

If the compressor is operating under limit condition, it is necessary to install an external oil cooler - please use hanbel program to determine the cooling capacity and oil flow.

It is suggested to use the lubricating oil with higher viscosity under bad working conditions; at this time, the discharge temperature is higher, which can reduce the viscosity of the lubricating oil. In addition, sometimes insufficient return oil of evaporator may happen in such as full liquid systems, which will result in oil loss of compressor. If there is insufficient return oil in the system, it is recommended to install a secondary oil separator between the compressor discharge port and the condenser to further reduce the amount of lubricating oil entering the system

- ⚠ It is recommended to install the optional oil level switch to avoid the oil level too low.
- ⚠ Compared with the piston compressor, the screw compressor can withstand a certain short-term liquid compression, but the long-term liquid compression affects the viscosity of the lubricating oil, and the bearing lubrication is insufficient, which easily causes the compressor to jam.

6.1 Lubricant configuration

Each compressor is specially equipped with different lubricating oil according to refrigerant. Please contact Hanbell for details.

- ⚠ **Note:** please contact Hanbell for special oil requirement.

6.2 Pre-cautions for changing oil

1. User should choose the oil with quality certification, and different brands of oil shall not be mixed. Different kinds of refrigerants should correspond to different lubricating oils, and special attention should be paid to the incompatibility between synthetic oil and mineral oil. Make sure the system is clean and free of welding slag and other impurities before oil filling.
2. Synthetic oil should be used in the water chiller to ensure that the oil is not exposed to the atmosphere for a long time, and the system should be thoroughly vacuumized at the initial start-up
3. In order to dehumidify the system, it is suggested that dry nitrogen should be introduced into the system for drying, and then vacuum treatment should be carried out. When vacuumizing the system, it should be considered that the low-pressure water vapor will evaporate. At this time, part of dry nitrogen should be refilled into the system. In addition, it is also very important for the system to replace the new oil, especially after the motor is burned down, the acid residue remains in the system. The acidity of the system lubricating oil can be checked by changing the oil, and the lubricating oil can be changed again after 72 hours of operation until the acidity of the lubricating oil reaches the standard value.
4. When filling the lubricating oil, it is necessary to ensure that the total amount of lubricating oil in the system reaches the filling quantity required by Hanbell.

6.3 The Replacement of Lubricating oil

1. Check the oil every 10,000 hours after continuous running. For the first operation of the compressor, it is recommended to change the oil and clean the external oil filter after running 2,000 hours. Check the system whether clean or not and then change oil every 20,000 hours or after 4 years continuous running if the system operates in good condition.
2. It is necessary to avoid solid residues and metal impurities passing through the oil filter as these impurities may cause bearing damage. In order to prevent bearing damage in this case, it is recommended to install a pressure difference switch (optional). When the differential pressure on both sides of the oil filter reaches the set value, the switch will act to shut down the system.

7. System Application

7.1 Principle & Application of economizer

RC2-D series compressor is equipped with economizer stop valve as standard. The stop valve can be rotated and locked with internal and external thread of flange, and can be connected in any direction, which is convenient for use.

The economizer's pressure is very close to the intermediate pressure of Hanbell compressor, this economizer port design can realize no compression backflow loss, so as to ensure that the compressor can maintain the best operation state in the whole load stage. With these characteristics, if the screw compressor can be designed to add a system of subcooling circuit or a flash drum for two-stage expansion to inject gas into the economizer port, it is possible to improve the efficiency. Especially under the condition of high compression ratio, the power consumption of the compressor increases very little, which can not only achieves a better energy efficiency ratio, but also improves the refrigeration capacity, efficiency and reliability of the system.

Please get efficiency of the economizer through hanbell selection program.

7.1.1 Sub-cooled Economizer System

The subcooled economizer system uses a heat exchanger (subcooler) to subcool the liquid refrigerant. A part of the refrigerant from the condenser is injected into the subcooler, and the throttled refrigerant will evaporate and absorb heat in the subcooler, so as to achieve the subcooling effect. The superheated steam enters the compressor through the economizer and mixes with the partially compressed gas from the evaporator. Because the supercooled liquid is under the condensation pressure, there is no special requirement for the connecting pipeline between the supercooled liquid and the evaporator, only the heat insulation is needed. This system is suitable for general application.

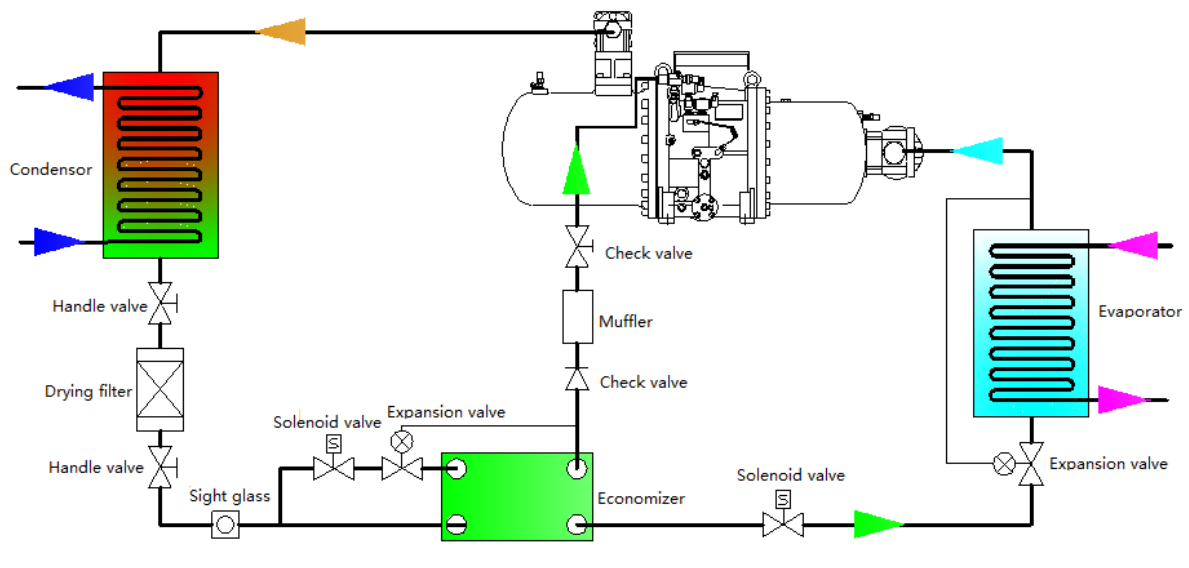

7.2 Application of pressure maintaining valve

When the difference between oil pressure and suction pressure is less than 4 bars, it may lead to capacity-control system failure, insufficient lubrication, and serious damage to the compressor, so the pressure maintaining valve is recommended to be installed. In addition to the installation of pressure maintaining valve, it is also recommended to install high and low pressure difference switches. If necessary, please contact hanbell for specific information.

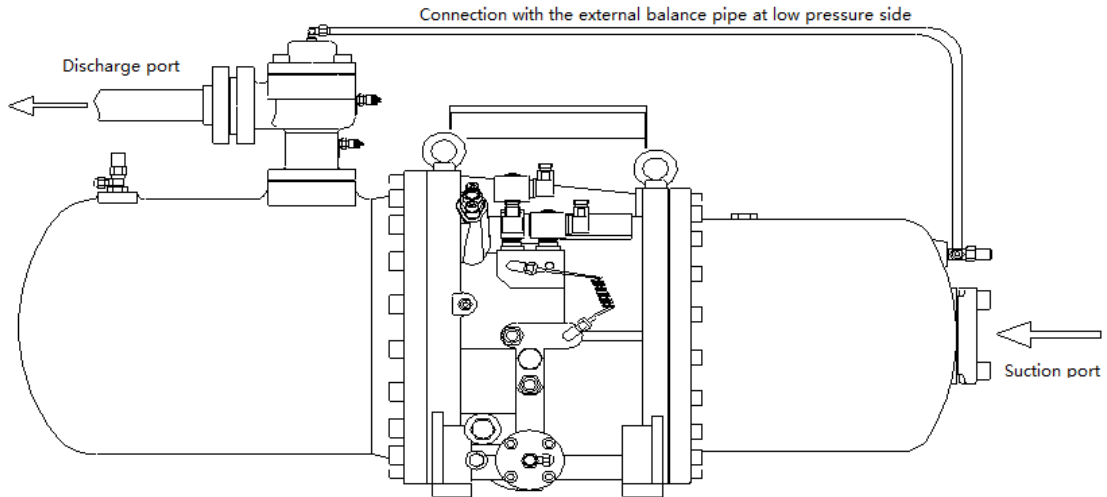

Application of pressure maintaining valve - Single compressor

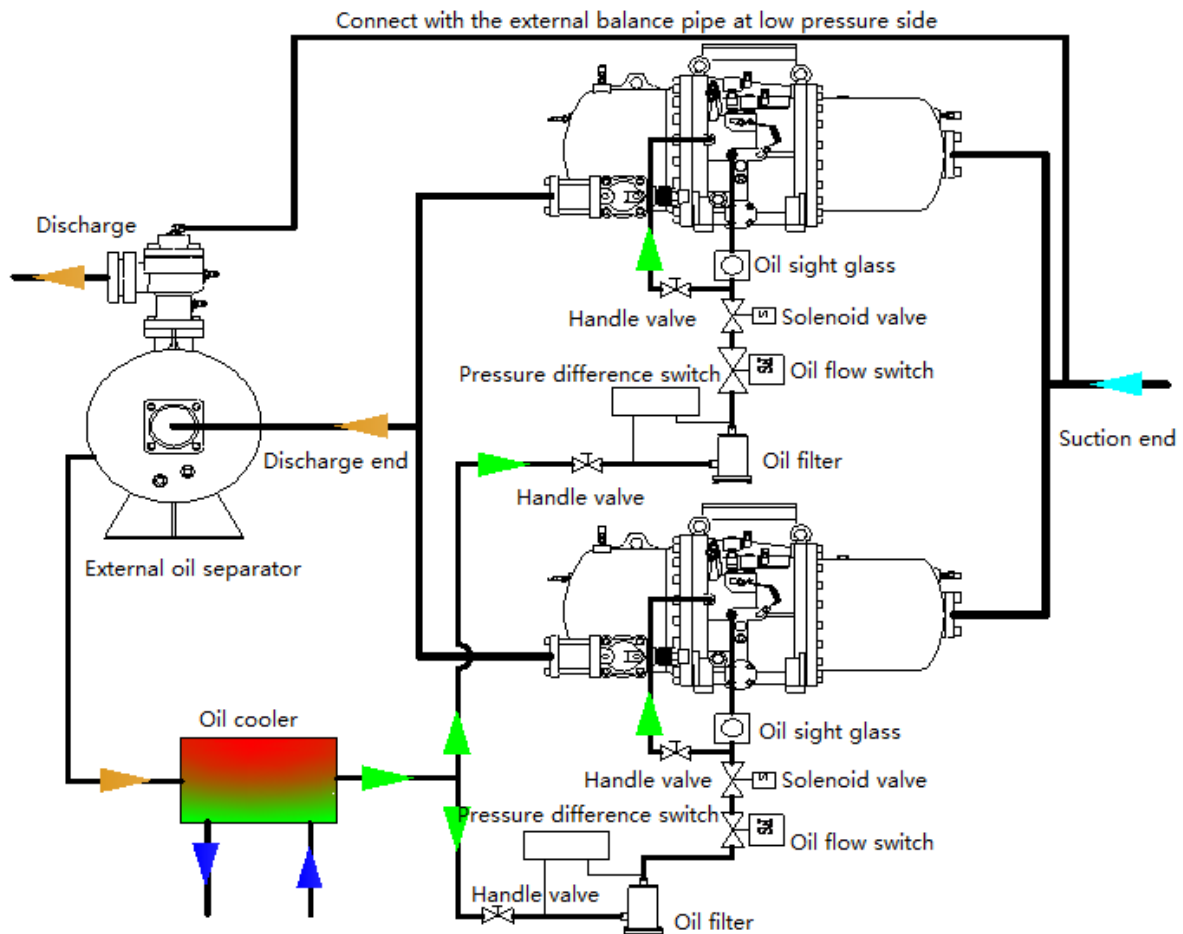

Application of pressure maintaining valve - Parallel connection

7.3 Application of parallel connection system

Hanbell RC2-DP screw compressor is especially suitable for parallel connection, and has the following advantages:

- 1 Expand the range of refrigerating capacity
- 2 Parallel connections of compressors with the same or different cooling capacity
- 3 No loss energy regulation
- 4 Optimized oil distributions (sharing one reservoir)
- 5 Small power loads at startup
- 6 High operation reliability
- 8 Simple installations

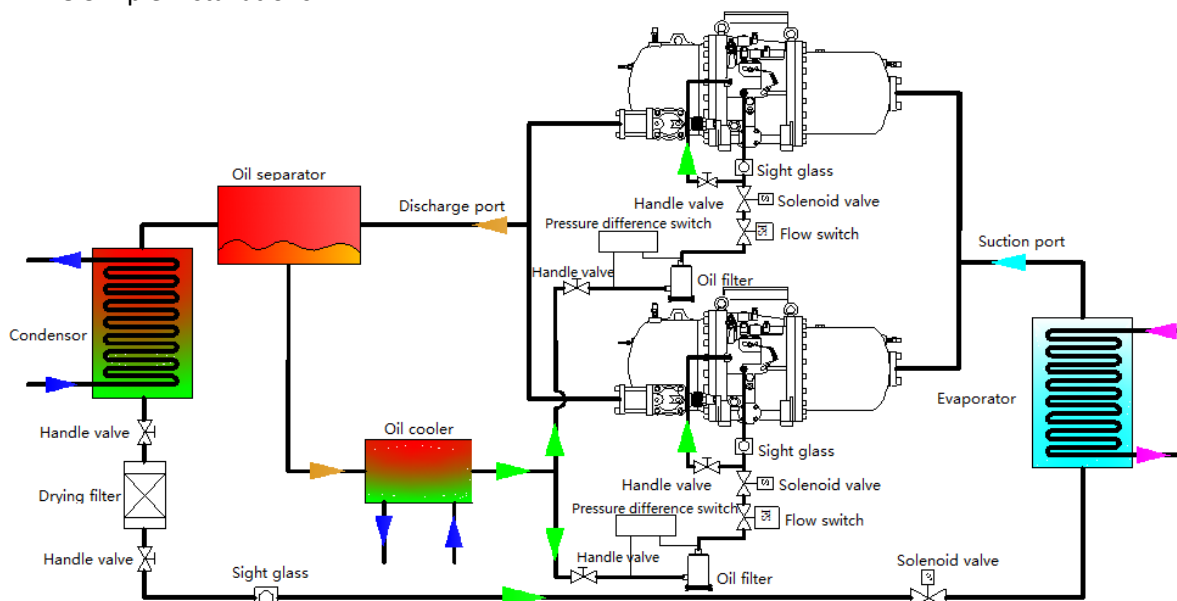

Diagram of parallel compressor sharing oil separator and oil cooler

7.4 Discharge temperature control - oil cooler application

Compared with the liquid injection, the application of oil cooler can reduce the discharge temperature and help the system achieve higher efficiency. Oil cooler can be divided into three categories: refrigerant cooling, air cooling and water cooling. The capacity of oil cooler can be calculated by manual or Hanbell program. When calculating manually, the worst operating conditions should be considered: the lowest evaporation temperature, the maximum suction superheat, the maximum condensation temperature and the operating mode.

⚠ Note: Hanbell requires that the pressure drop of the external oil system should not exceed 1 bar, so as not to affect the normal loading and unloading of the compressor.

7.4.1 Refrigerant cooling

The liquid refrigerant is used as cooling medium. The basic system is shown in the figure below:

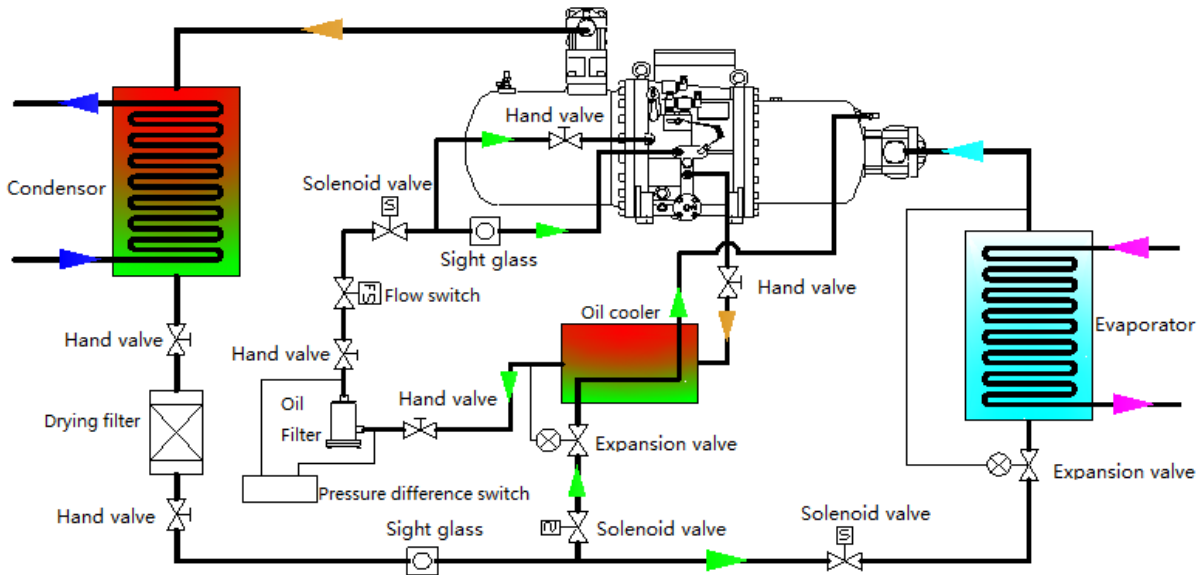

Diagram of refrigerant cooling system (single compressor)

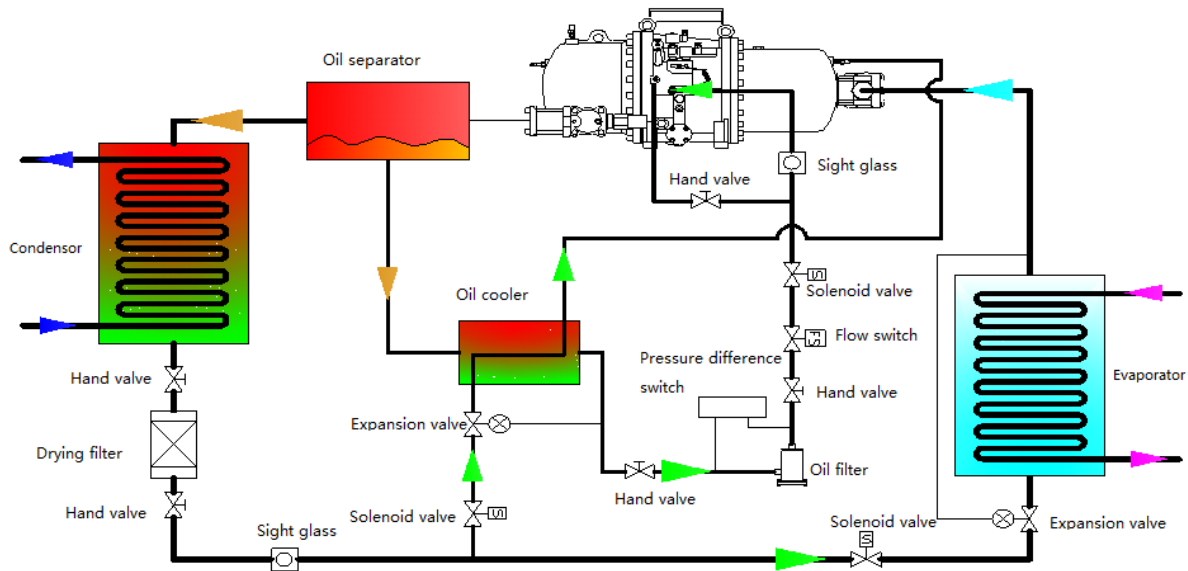

Diagram of refrigerant cooling system (Parallel connection)

7.4.2 Water cooling

The water cooling system is to use a shell-tube type heat exchanger and a cold source from an external cooling tower or evaporative cooler, or use a water pump to make the cooling medium water circulate and release heat to the environment in the cooling tower or evaporative cooler. The water cooling system diagram is shown in the figure below.

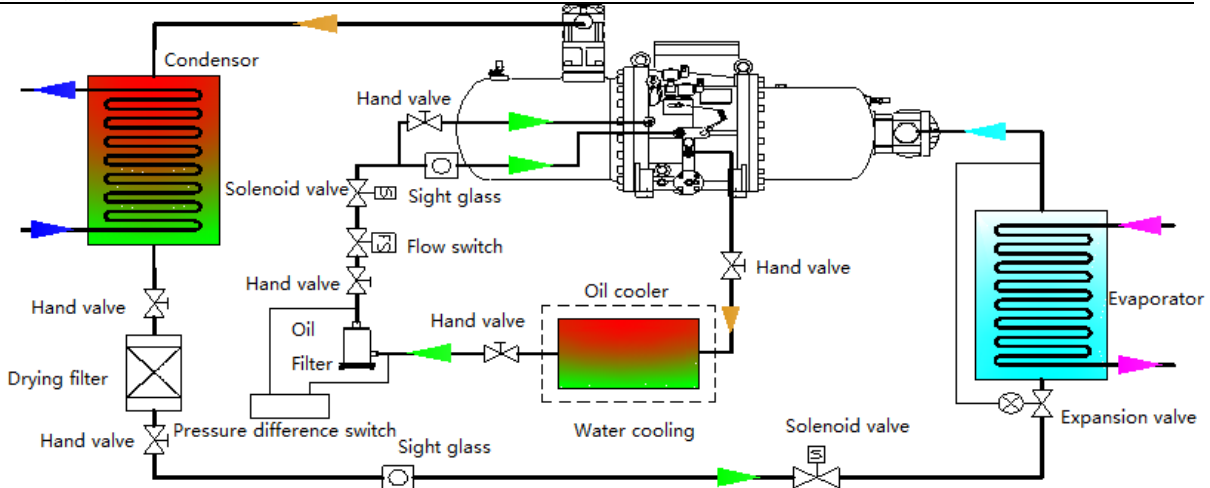

Diagram of water cooling system (single compressor)

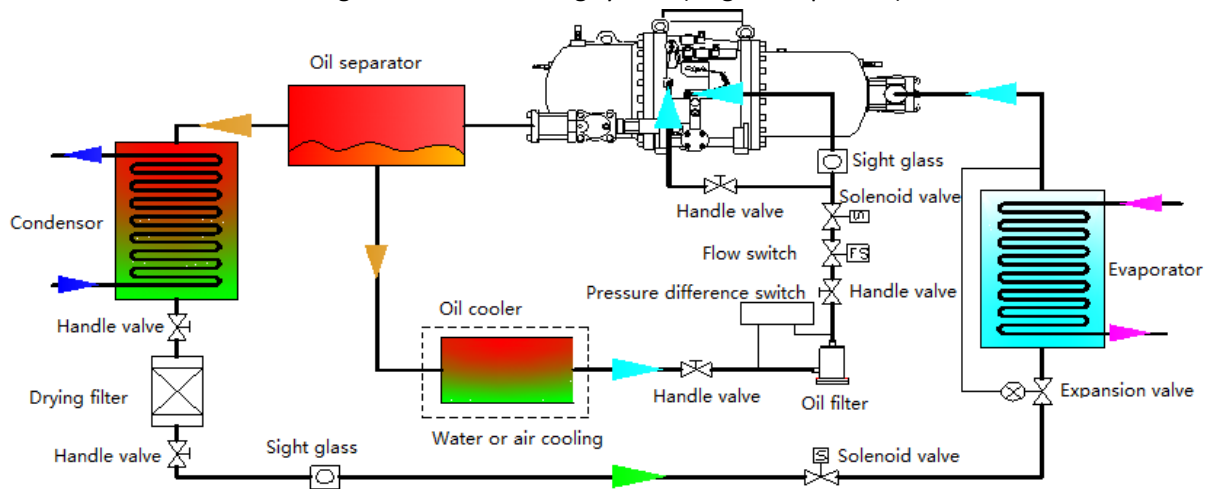

Diagram of water cooling system (Parallel connection)

7.5 Motor temperature control - Application of liquid injection

When the compressor starts up, the suction temperature is too high or the compressor operates under the following conditions, it is recommended to use the motor liquid injection to reduce the motor temperature, so as to ensure the safe and efficient operation. B D

- R22 refrigerant, condensation temperature > 40 °C
- R404A / R507 refrigerant, condensation temperature > 35 °C

7.5.1 Application

An auxiliary cooling system should be provided in the region with high condensation temperature or low evaporation temperature on the operation range diagram to prevent compressor overheating and ensure the normal operation. The simple auxiliary cooling way is to directly lead a pipe from the system liquid pipe into the preset liquid injection connector of the compressor to cool the motor. For the liquid injection system, the injection controller is optional. The liquid injection controller reads the temperature through embedded NTC, and then automatically controls the liquid injection. When the motor temperature is more than 80 °C, the injection is turned on; When the motor temperature is less than 60 °C, the injection is closed.

7.5.2 Liquid injection diagram

The NTC resistance signal of the built-in motor temperature of the compressor controls the motor liquid injection solenoid valve according to the motor temperature. It is recommended to open at 80 °C and close at 60 °C

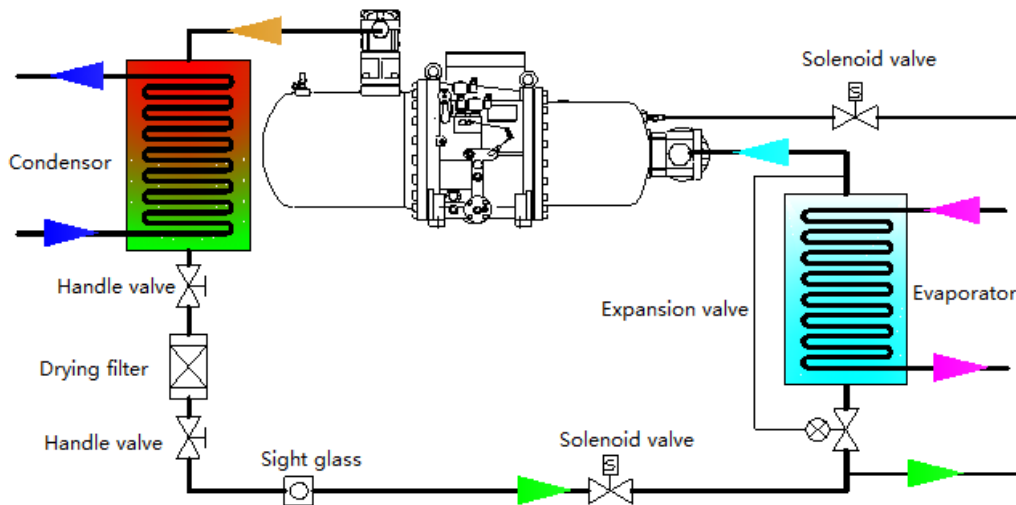

7.6 Key points for compressor application

7.6.1 Pump-down

Do not pump-down the refrigerant in the compressor except for temporary maintenance or long term shutdown. The pump-down will cause the refrigerant at the suction side to be insufficient, which leads to abnormal high temperature in the compression chamber and the motor overheating.

When pump-down, please pay attention to the following items:

- 1) It is recommended to pump-down when the compressor is at 100% load.
- 2) The pump-down should be completed at one time, because the repeated pump-down is harmful to the compressor and compression chamber.
- 3) When pump-down, the minimum suction pressure should be kept above 0.5bar
- 4) When pump-down, the discharge temperature should be kept less than 100C.
- 5) Pay attention to the high and low pressure of the compressor and the noise during operation. If there is any abnormal situation, stop the pump-down immediately.

7.6.2 Long term partial load operation

If the compressor must be operated continuously under the condition of less than 50% load, although the compressor is running in its limit curve or the motor temperature is lower than the overload trip setting value, the motor heat dissipation will be insufficient due to the low suction. If the compressor is running for a long time under high temperature, the motor will be deteriorated gradually due to insufficient heat dissipation, and the motor will be seriously damaged. When operating under this severe condition, it is recommended to open the liquid injection when the motor coil temperature exceeds 80 °C.

8. Operation and Maintenance

8.1 Compressor Installation

8.1.1 Compressor Lifting

Upon receiving the compressor, please check if the crate is intact, and compressor is in good condition. Please also check accessories and documents to be consistent with order. When lifting the compressor, it is recommended to use steel cable or cable as shown in the following figure. For RC2-100~930, a safety cable capable of bearing 2 tons of weight is required. Keep the compressor in horizontal position when lifting, and prevent it from crashing, falling on the ground or any other accident that may damage compressor or its accessories.

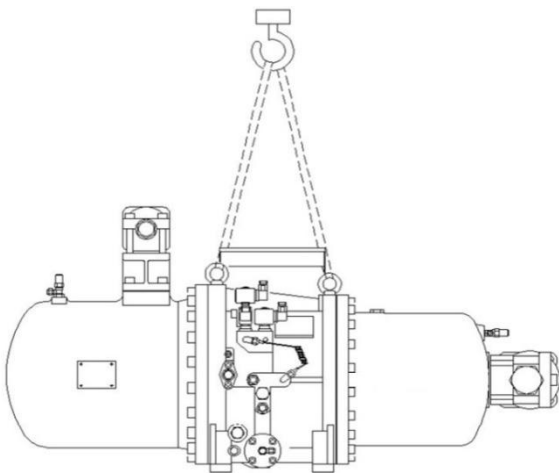

Lifting compressor with steel cable

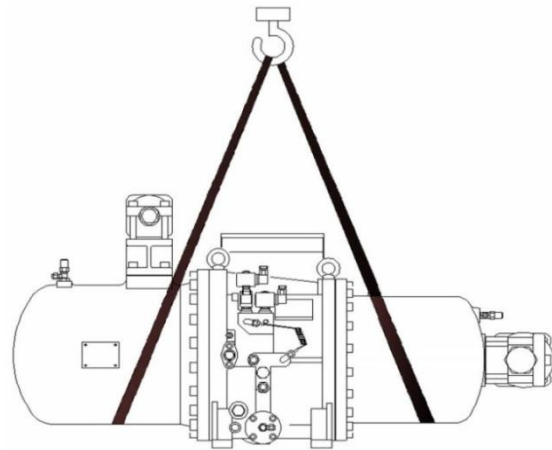

Lifting compressor with safety cable

8.1.2 Compressor Installation

When installing the compressor, it is necessary to ensure that the system is away from the heat source to avoid heat radiation. The compressor shall be installed as close to the power supply as possible for wiring, and the air and drying in good environment shall be maintained. Ensure the foundation strength is enough to avoid additional noise and vibration during compressor operation, and enough space shall be reserved for compressor maintenance in the future. In addition, the compressor shall be installed horizontally and rubber damping pad shall be installed to avoid vibration transmission between compressor and pipeline during operation.

8.1.3 Precautions for compressor piping

Improper piping will cause abnormal vibration and noise, and damage compressor. In order to prevent this kind of situation, please pay attention to the following points:

- 1) After welding pipes, the system should be kept clean to avoid welding slag and other impurities accumulated in the system, resulting in serious damage.
- 2) In order to reduce pipe vibration, it is suggested to use copper pipe at suction and discharge side.

When the compressor is running, the copper pipe can reduce the vibration. If steel pipe is necessary, proper welding is very important to avoid stress in the pipeline system. These internal stresses will cause resonance and noise, which will reduce the life-time of the compressor.

3) The oxidation impurities and debris in the pipeline due to welding should be removed. If these impurities enter into the compressor, the oil filter may be blocked, and the lubrication system and the capacity-control system may be invalid.

4) The material of suction and discharge flange is steel, which can be directly welded with pipeline. After welding, it should be cooled in the atmosphere and is forbidden to use water for cooling.

8.1.4 Angle limit of compressor installation

Below picture shows the maximum inclination angle when the compressor is installed. If the inclination angle is bigger than the limit value, the oil level will be too low which causes the compressor to stop. However, in some special applications, the inclination may exceed the limit. For example, when it is used on the ship, it is recommended to have an external oil separator and associated auxiliary components. Please contact Hanbell for further installation instructions.

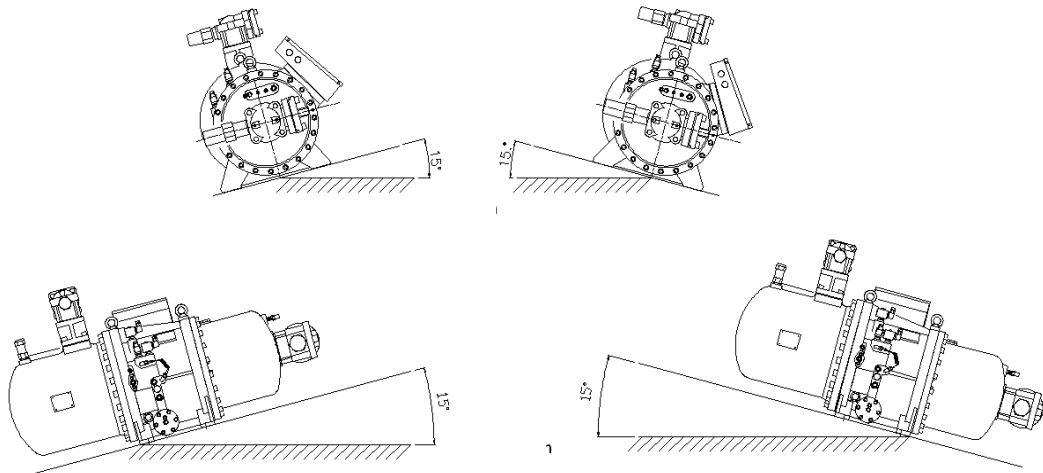

Inclination angle of compressor installation

8.1.5 Ambient temperature

The ambient temperature shall be between -15°C and $+50^{\circ}\text{C}$.

8.1.6 Suction superheat

R22: 5~10 K

R507A/R404A : 5~10 K (Recommended minimum 8 K)

Note: suction superheat is the difference between suction temperature and dew-point temperature under evaporation pressure.

8.1.7 Design pressure

Maximum working pressure: low/high pressure: 12.5 / 25 bar

In order to prevent the compressor from operating beyond the limit allowable range, it is necessary to install high pressure and low pressure switch.

The design and test of the compressor conform to Chinese national standard GB/T 19410.

8.1.8 Capacity state during startup

In order to start the compressor, the starting torque must be higher than its resistance torque. To this end, the compressor must start at the minimum capacity state (25% or 33%).

8.1.9 Startup times

RC2-100~580D can start up to 6 times per hour at most, and RC2-620~930D can start up to 4 times per hour at most; Operation at least 5 minutes each time.

8.1.10 Compressor start

The table below is the check list which needs to be done before the compressor start.

Item	Main points to check	Corresponding status
Appearance	1. System valve status 2. Capacity –control solenoid valve 3. Capillary	1. Open 2. Installed 3. No severe distortion and damage
Electrical system	1. Main power supply voltage 2. Control circuit voltage 3. Insulation resistance between the motor interphase & insulation resistance of ground 4. Connection of power supply 5. Grounding wire installation 6. Switch, sensor and controller settings	1. The range of voltage fluctuation is controlled within 5% of the rated voltage, and the instantaneous voltage drop is less than 10%. 2. Standard voltage is 220V±10%; for special requirements, please contact Hanbell. 3. The insulation should be higher than 5 MΩ. 4. The power supply is connected to the terminal box and it should have good insulation. The power line should be far away from the heat source and metal parts with edges and corners to avoid the damage of the insulation skin. The power supply should be well installed and shall have good insulation. Terminal box and bolt shall be provided. 5. Confirmation of installation. 6. Refer to Chapter of Protection Device.
Piping system	1. Output piping system 2. Leakage test 3. Compressor fixing bolts	1. Proper installation 2. No leakage 3. Well locked
Safety device	1. Motor coil sensor PTC (thermistor) 2. Discharge temp sensor PTC 3. Controller 4. Motor coil temp sensor NTC	1. Connect to the controller together with the discharge temperature sensor 2. Connect to the controller together with the motor temperature sensor 3. Closed circuit. 4. Connect to the control system and display on the screen.

In addition to the items which need to be checked in the above table, the following contents should be considered before start-up as well:

1. When the condensing sytem operates on site, special attention should be paid to its auxiliary equipment, as well as the maintenance period after the initial start-up.
2. In order to keep the viscosity of lubricating oil normal at low ambient temperature and the smooth of capacity-control, it is recommended to keep the oil heater on the external oil separator open as soon as the compressor is switched off in order to prepare for the next start-up.

3. Make sure each pressure switch is set correctly.
4. Make sure all check valves are in open state.
5. Start the compressor shortly (about 0.5-1 second) to ensure that the rotation is normal, through monitoring the suction and discharge pressure.

⚠ Note: Normal rotation judgment method: suction pressure drops immediately, while the pressure rise.

1) After start-up, the lubricating oil in the external oil filter should be checked. The oil level should be within the visual range of the sight glass or higher than the middle line of the sight glass.

2) When the compressor starts, the oil in the separator will produce foam, but when the compressor operates under the rated condition, the foam will decrease; otherwise it means too much liquid in the compressor or excessive discharge temperature.

3) The working condition should be adjusted according to the following ways: The discharge temp should be 30K higher than the condensation temp, and the difference between suction superheat and evaporation temperature should be within 15K.

4) The whole system, especially the pipeline and capillary, must pass the vibration test. If there is abnormal vibration or noise during operation, please contact Hanbell.

5) If the compressor operates for long time, the following items should be inspected daily:

- The operation data such as 3-phase voltage, compressor line current, etc.
- Check lubricity of the oil and its level
- Check all the sensor of compressor
- Check the connection of the wire and its fastening property
- Check the sight glass of the oil circuit

8.2 Compressor maintenance

The compressor can not be operated normally for without regular maintenance. The following items need to be maintained regularly:

8.2.1 Maintenance instructions of suction filter

Regularly check the pressure difference at both ends of the suction filter. If the pressure difference is greater than 0.5bar, clean or replace it. The pressure detection points are as shown in the figure.

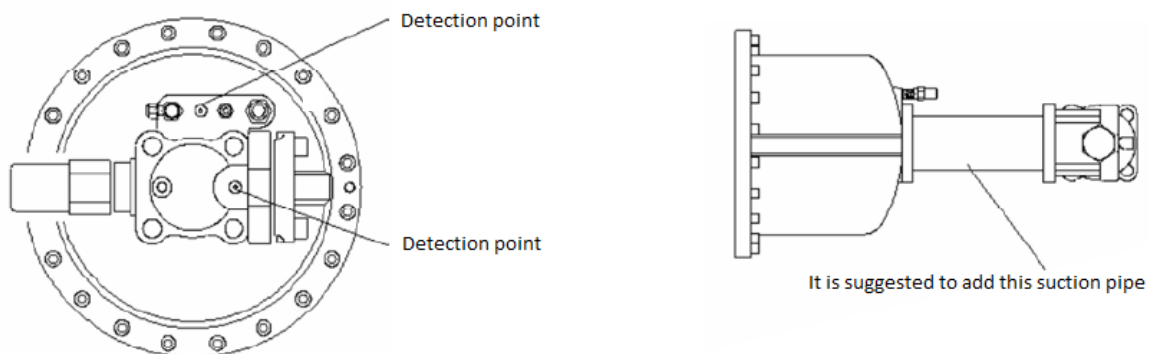

The steps are as follows:

1. Shut off the suction & discharge stop valve, oil line hand valve and liquid injection hand valve to release the pressure in the compressor.

2. Remove the bolts on the suction flange and stop valve, and remove the pipeline from the suction port of the compressor to the suction stop valve.
3. Take out the suction filter; after cleaning or replacement install the clean suction filter back, install the suction pipe, and lock the bolt (Please do not miss the gasket. If it is damaged, please replace it).
4. After the compressor is evacuated to -0.6Bar, open the valve closed before.

8.2.2 Common fault analysis

Below table lists some of the faults which occur in normal working condition and when it exceeds the limit working condition. This table is only a guide for engineers to understand the faults on site.

⚠️ Note: The replacement of the internal parts of compressor must be carried out by the person who has the service technical qualification certificate and understands Hanbell screw compressor, or the service engineer of Hanbell.

Fault	Possible cause
1. Tripping of motor coil temperature protection	<ol style="list-style-type: none"> 1. The refrigerant suction pressure too low; temperature too high (refrigerant is insufficient or the suction filter blocked). 2. Too large motor load; insufficient cooling; liquid refrigerant injection device is not installed or failure. 3. Coil protection switch failure. 4. Electrical system failure. 5. Poor motor coil or temperature too high. 6. Excessive suction superheat and poor heat dissipation.
2. Compress fail to load	<ol style="list-style-type: none"> 1. Ambient temperature too low; viscosity of lubricating oil too high. 2. Capillary blocked. 3. Discharge port of the capacity-control stuck and cannot be closed. 4. Capacity-control piston stuck 5. Capacity-control oil line stuck 6. Oil filter stuck
3. Compressor fail to unload	<ol style="list-style-type: none"> 1. The piston ring cannot be completely airtight, and a large number of refrigerant come into the capacity-control oil cylinder 2. Capacity-control solenoid valve coil failure 3. The discharge side cover gasket is broken and the gaseous refrigerant enters the oil cylinder. 4. The capacity-control solenoid valve coil voltage faulty 5. Capacity-control piston stuck 6. Poor control procedure
4. Poor insulation of motor	<ol style="list-style-type: none"> 1. Compressor motor wire connector wet or condensation 2. Poor compressor motor 3. Poor motor terminal or stuck by dust or foreign body. 4. Bad insulation of electromagnetic contactor 5. Internal acidification of the system which destroys insulation. 6. Long term coil running at high temperature, leading to insulation deterioration. 7. Frequent startup, coil degradation. 8. Too much water contained in the refrigerant

5. Motor fail to start or Y- Δ fail to switch	<ol style="list-style-type: none"> 1. Full load start, the capacity-control valve does not return to its initial state. 2. Voltage too low or voltage wrong 3. Starting voltage drop too large, electromagnetic contactor cannot pull in. 4. Motor failure 5. Operation when phase shortage or reverse 6. Motor protection switch activated 7. Wrong wiring of the motor coil 8. Poor Y-Δ start timer 9. Restart is less than 3 minutes from the previous start 10. The current setting is too small or the improper selection of circuit breaker. 11. The connecting of Y-Δ is not secured 12. Poor electromagnetic contactor
6. Abnormal vibration or noise	<ol style="list-style-type: none"> 1. Bearing damage 2. Liquid compression 3. Rotor overheating due to mutual friction or friction with the casing. 4. Lubrication failure caused by oil loss 5. Internal parts loose 6. System pressure disorder 7. Resonance caused by poor piping, no flexible stretch 8. Foreign objects come into the compressor chamber
7. Discharge temperature too high	<ol style="list-style-type: none"> 1. Excessive refrigerant superheat (refrigerant shortage, expansion valve abnormal) 2. High pressure too high (bad cooling, air enters the system, cooling water temperature too high, cooling water flow insufficient, condenser heat transfer effect poor). 3. Compression ratio too large and no auxiliary cooling 4. Bearing damage, rotor friction. 5. Oil loss or oil level too low

8.2.3 Troubleshooting

INT69HBY Diagnose troubleshooting:

Fault	Phenomenon	Troubleshooting	
1. Abnormal power supply of module	Red flash 3; Orange flash 1	The power supply of the module is too low. The normal operating voltage of NT69HBY Diagnos is 115v-240v (- 15% ~ + 10%)	
2. The module is not abnormal, but the unit fail to start	Green light on	Measure the resistance between M1& M2, if it is disconnected, replace protectors.	
3. PTC abnormal	Red flash 1; Orange flash 1	Confirm if the temperature is too high; If not, start the compressor after the automatic reset delay. If manual reset is required, confirm that the light is red flash 1 and orange flash 3, wait for 5 minutes, then start the compressor	After high temperature protection, the automatic reset delay time after the temperature drops to normal value First: 5min Second: 60min Third: Manual reset
	Red flash 1; Orange flash 3	Reset delay after temp protection	
	Red flash 1; Orange flash 4	Check if terminal is in poor connection	
4. Abnormal voltage	Red flash 2; Orange flash 1	Check if the phase sequence of power is correct	After the 3-phase voltage protection, the problem should be solved before manual reset
	Red flash 2; Orange flash 2	<ol style="list-style-type: none"> 1. Measure if the unbalance rate of 3-phase voltage is less than 15% 2. check if the power is broken phase 	

9. Operation Range

The operating range of compressor is related to the refrigerant used. It is very important to ensure the compressor to operate within the operating range. Operating at too low suction temperature may lead to the problems of lubricating oil viscosity and insufficient cooling of motor. Operating at too high condensation temperature may reduce the service life of compressor due to insufficient cooling of motor and compression chamber. Therefore, special attention should be paid to the operating load and operating range of the compressor.

9.1 RC2-D Operation range

- When compressor is under partial load or full load, the temperature of motor coil and discharge gas will rise at the same time. In order to ensure the safe operation of, the use of the following external cooling devices is necessary.
 - Oil cooler
 - Motor liquid injection cooling
 - Please select the appropriate external cooling device according to hanbell program. It is necessary to install pressure difference switch or pressure maintaining valve to ensure that the oil pressure is 4bar higher than the suction pressure to ensure that there is enough oil for sealing, lubrication and capacity control.
 - For operating conditions outside the range, please contact hanbell.
- It is suggested that the minimum value of discharge superheat should be kept above 30K of condensing temperature (R22 discharge superheat is generally about 30K) to prevent liquid injection backflow, which will cause compressor and lubrication failure.
- The maximum suction superheat should be kept within 15K to prevent high temperature caused by poor heat dissipation of motor and high discharge temperature.

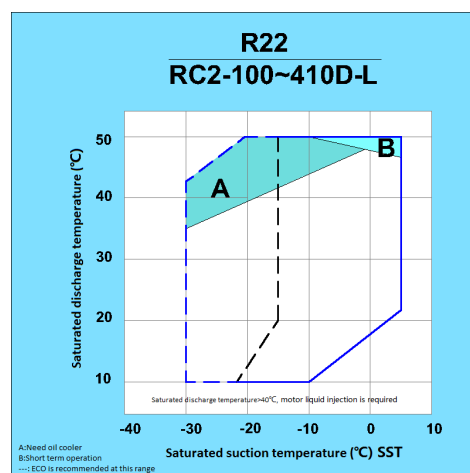
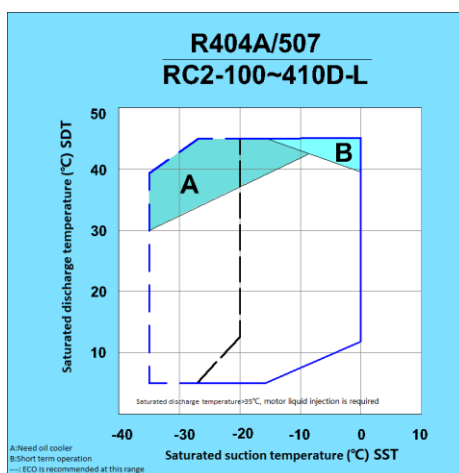

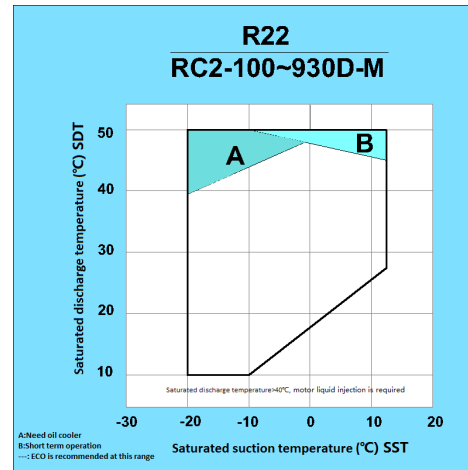
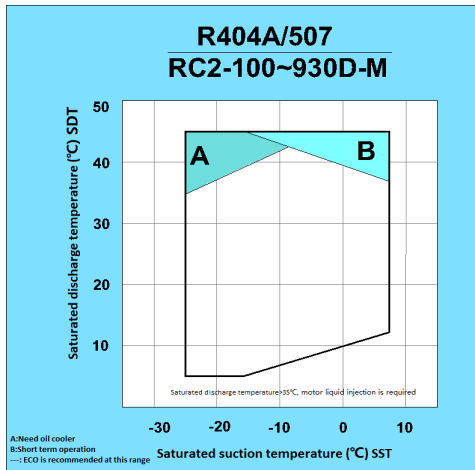
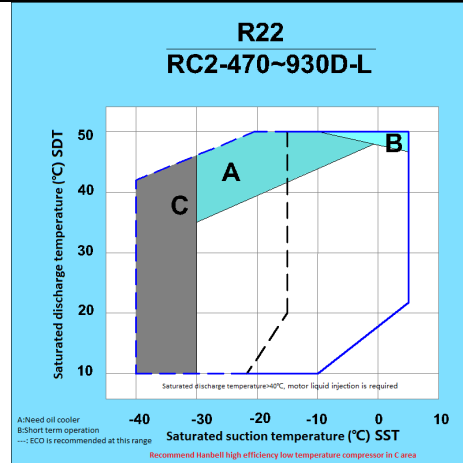
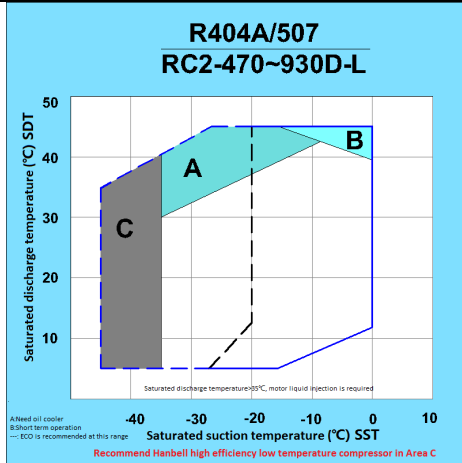

Note: The operation range of RC2-D-L is shown in the blue full line area, and the operation range of RC2-D-M is shown in the black full line area.

In order to avoid high temperature of compressor motor caused by high suction superheat or high pressure, it is recommended to install motor liquid injection system

10.Appearance Drawing

10.1 RC2-100~930D-S Drawing

RC2-100/140D-S Drawing

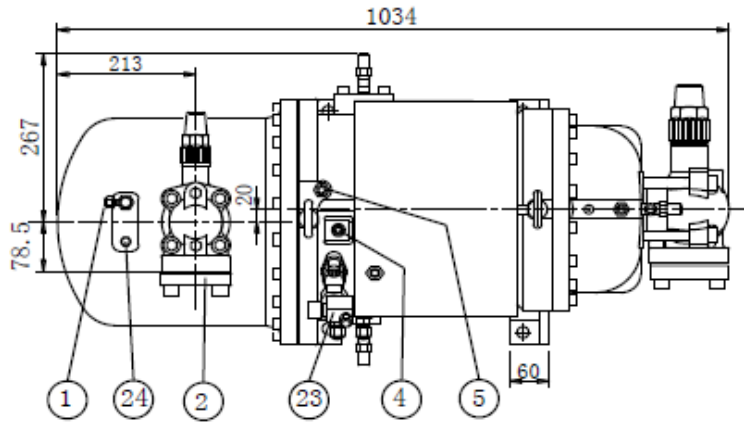

No.	Part Name	Remark	No.	Part Name	Remark
1	High pressure side angle valve	1/4" Flare	14	Low pressure side angle valve	1/4" Flare
2	Discharge flange	1-1/2"	15	Refrigerant filling valve	1/4" Flare
3	Solenoid valve	33% loading	16	Motor liquid injection port	1/2" Flare
4	Solenoid valve	66% loading	17	Suction flange	2"
5	Injection port	3/8" Flare	18	Terminal box	
6	Capillary		19	Cleaning cover flange	
7	Check valve	1-1/2"	20	Drain valve	
8	Oil sight glass		21	Oil level switch	
9	Oil heater	300w	22	Discharge temp sensor	110C
10	Oil filter		23	ECO stop valve	
11	Connector for pressure switch		24	Plug	
12	Oil outlet	3/8" Flare	25	Overflow hole	Optional
13	Oil inlet	3/8" Flare	26	Cover	
14			27	Oil block pin	Optional

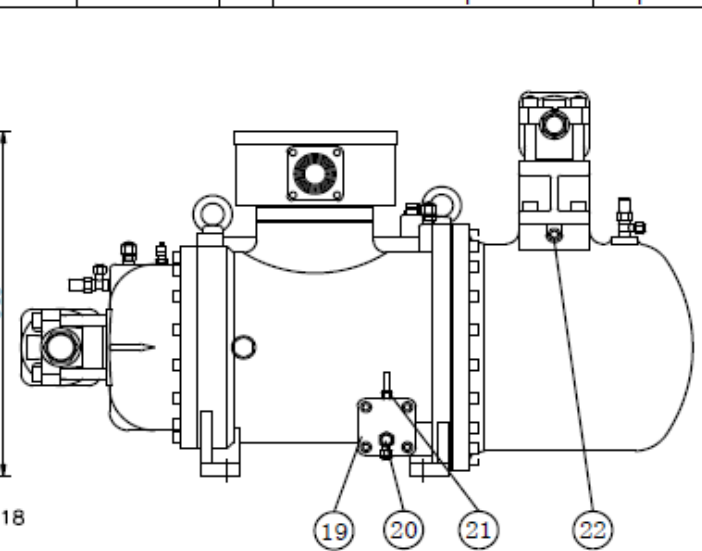
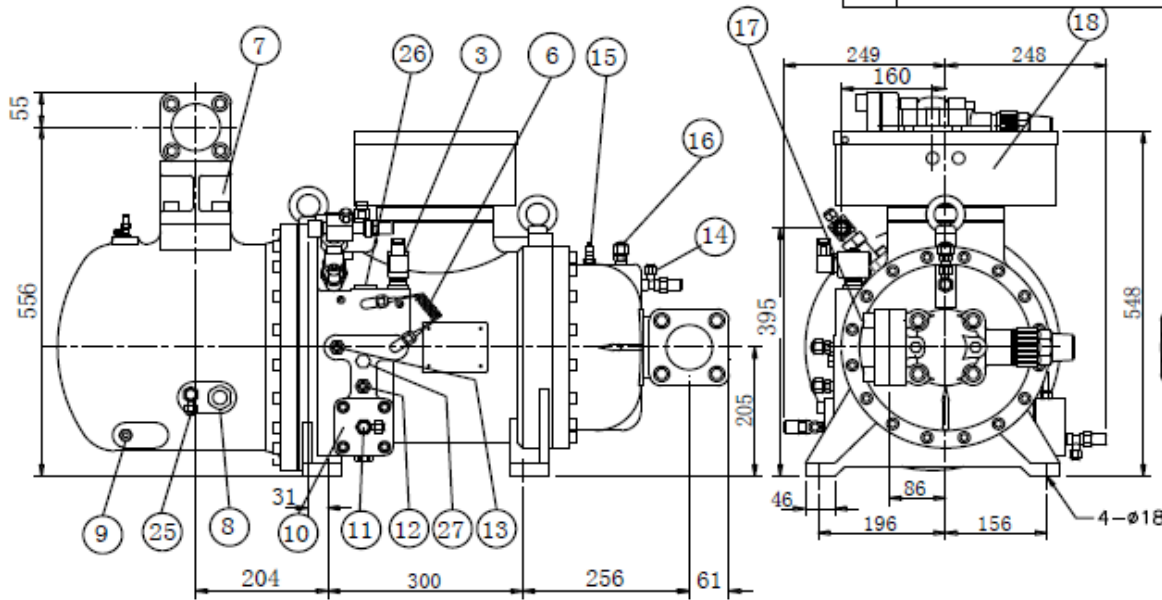

RC2-180D-S Drawing

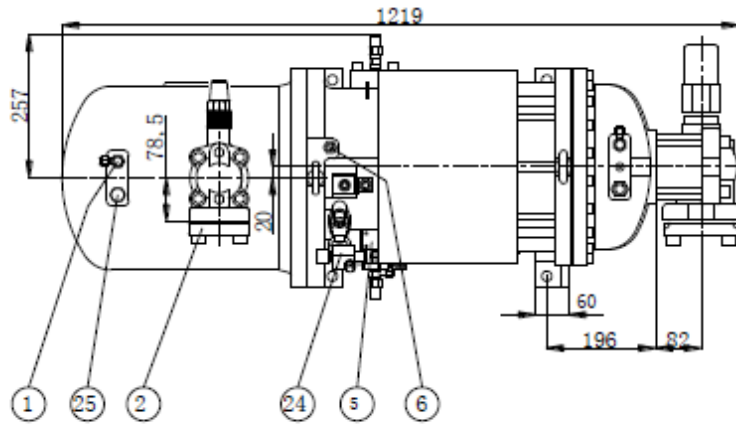

No.	Part Name	Remark	No.	Part Name	Remark
1	High pressure side angle valve	1/4" Flare	15	Low pressure side angle valve	1/4" Flare
2	Discharge flange	1-1/2"	16	Refrigerant filling valve	1/4" Flare
3	Solenoid valve	33% loading	17	Motor liquid injection port	1/2" Flare
4	Solenoid valve	66% loading	18	Suction flange	2-1/2"
5	Cover		19	Terminal box	
6	Injection port	3/8" Flare	20	Cleaning cover flange	
7	Capillary		21	Drain valve	
8	Check valve	1-1/2"	22	Oil level switch	
9	Oil sight glass		23	Discharge temp sensor	110C
10	Oil heater	300w	24	ECO stop valve	
11	Oil filter		25	Plug	
12	Connector for pressure switch		26	Oil block pin	Optional
13	Oil outlet	3/8" Flare	27	Overflow hole	Optional
14	Oil inlet	3/8" Flare			

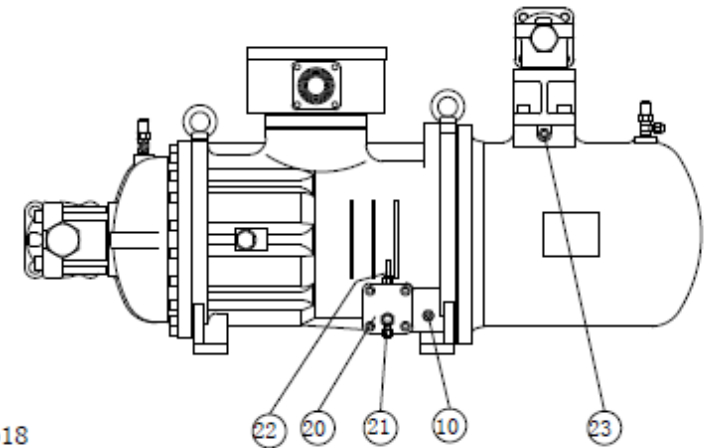
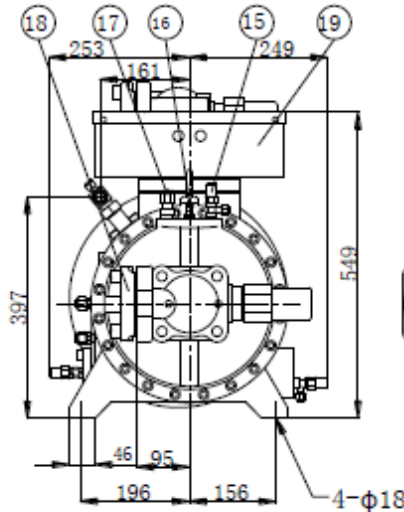
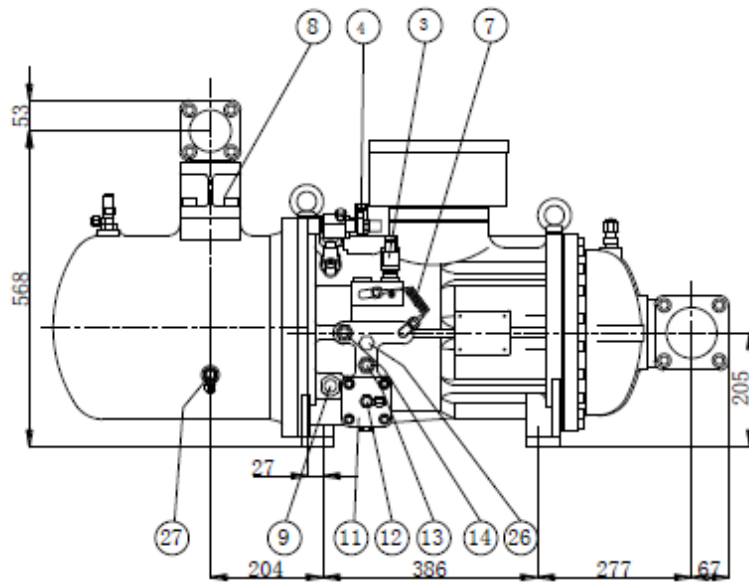

RC2-200~620D-S (Horizontal suction port) Drawing

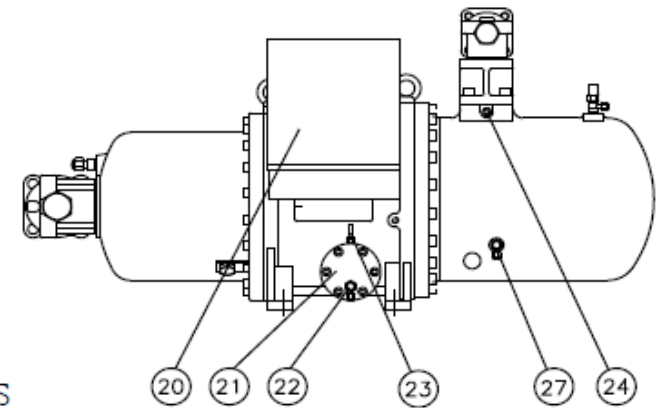
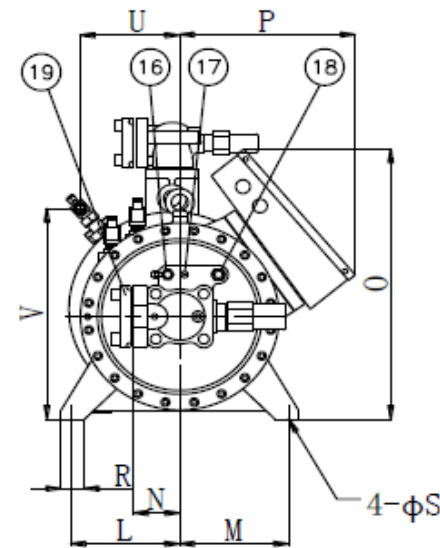
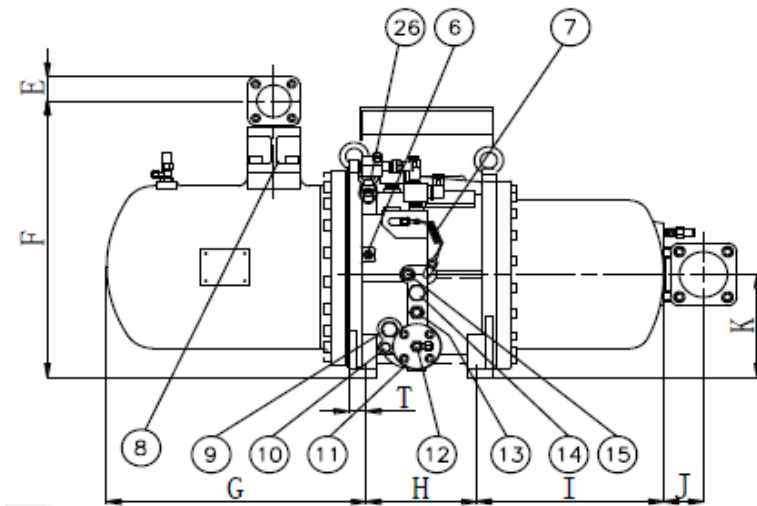
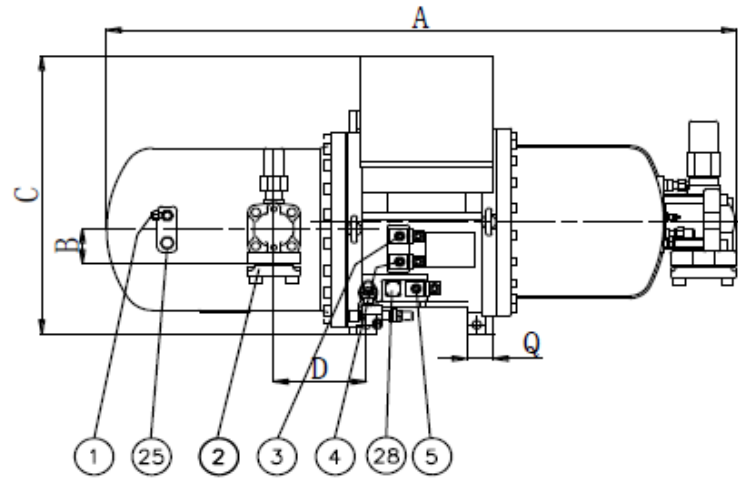

No.	Part Name	Remark	No.	Part Name	Remark
1	High pressure side angle valve	1/4" Flare	15	Oil inlet	
2	Discharge flange		16	Low pressure side angle valve	1/4" Flare
3	Solenoid valve	50% loading	17	Refrigerant filling valve	1/4" Flare
4	Solenoid valve	75% loading	18	Motor liquid injection port	1/2" Flare
5	Solenoid valve	25% loading	19	Suction flange	
6	Injection port		20	Terminal box	
7	Capillary		21	Cleaning cover flange	
8	Check valve		22	Drain valve	
9	Oil sight glass		23	Oil level switch	
10	Oil heater	300w	24	Discharge temp sensor	110C
11	Oil filter		25	Plug	
12	Connector for pressure switch		26	ECO stop valve	
13	Oil outlet		27	Overflow hole	Optional
14	Oil block pin	Optional	28	Cover	

Model	RC2 -200 ~620D-S (Horizontal suction port) Dimension																					
	A	B	C	D	E	F	G	H	I	J	K	L	M	N	O	P	Q	R	S	T	U	V
RC2-200D-S	1304	79	620	191	55	603	540	228	386	82	225	225	225	96	592	359	55	48	18	36	206	461
RC2 -230&260D-S	1399	86	682	202	61	674	567	251	399	97	257	240	240	107	622	386	55	48	18	19	223	523
RC2-300D-S	1476	86	682	202	61	674	610	285	399	97	257	240	240	107	622	386	55	48	18	37	224	523
RC2-310D-S	1484	86	682	202	61	674	610	251	444	97	257	240	240	107	622	386	55	48	18	37	224	523
RC2 -340&370D-S	1550	96	682	202	67	704	610	285	447	103	257	240	240	132	622	386	55	48	18	37	224	523
RC2-410D-S	1540	96	755	221	67	755	613	288	433	103	276	270	230	132	652	408	70	100	22	46	271	567
RC2-470D-S	1621	96	755	221	67	755	661	320	433	103	276	270	230	132	652	408	70	100	22	43	271	567
RC2-510D-S	1675	107	798	231	76	789	696	288	484	103	276	270	230	132	638	450	70	100	22	46	271	567
RC2-550D-S	1724	107	798	236	76	800	720	320	477	103	280	270	230	132	642	450	70	100	22	35	399	392
RC2-580D-S	1707	107	798	231	76	789	696	320	484	103	276	270	230	132	638	450	70	100	22	46	275	570
RC2-620D-S	1904	107	798	236	76	800	720	320	525	220	280	270	230	161	642	450	70	100	22	35	399	392

Model	RC2 -620 ~930D-S (Vertical suction port) Dimension																			
	A	B	C	D	E	F	G	H	I	J	K	L	M	N	O	P	Q	R	S	T
RC2-620D-S	1743	107	800	236	510	161	800	76	720	320	623	738	270	230	642	450	70	35	399	392
RC2-710D-S	1883	130	812	263	515	161	851	105	822	353	628	808	270	230	682	465	80	52	259	634
RC2-790&830D-S	1970	130	812	263	515	161	851	105	822	418	628	808	270	230	682	465	80	8	236	606
RC2-930D-S	2019	160	812	263	585	161	851	105	822	418	698	808	270	230	682	465	80	8	236	606

RC2-620~930D-S (Vertical suction port) Drawing

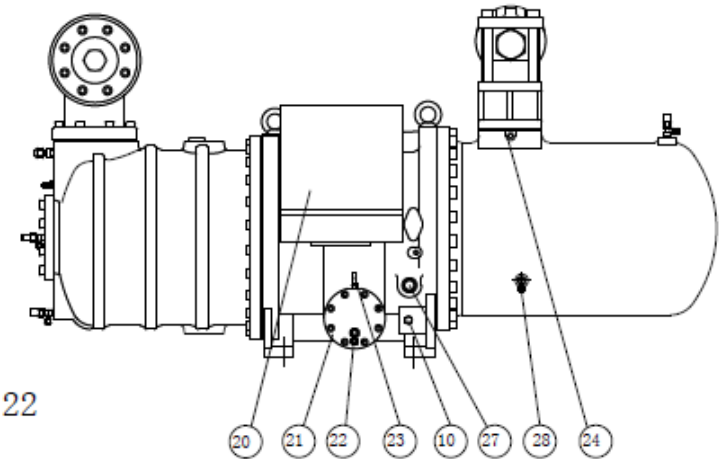
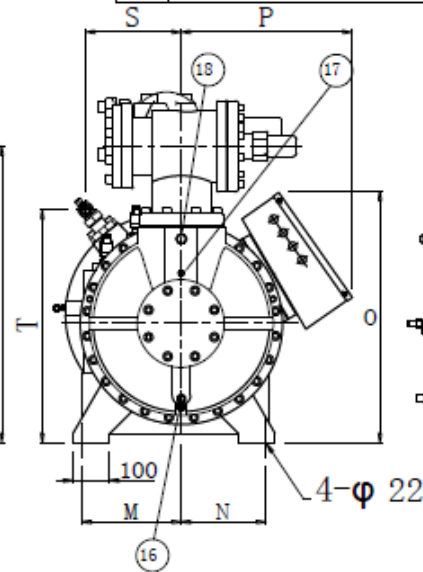
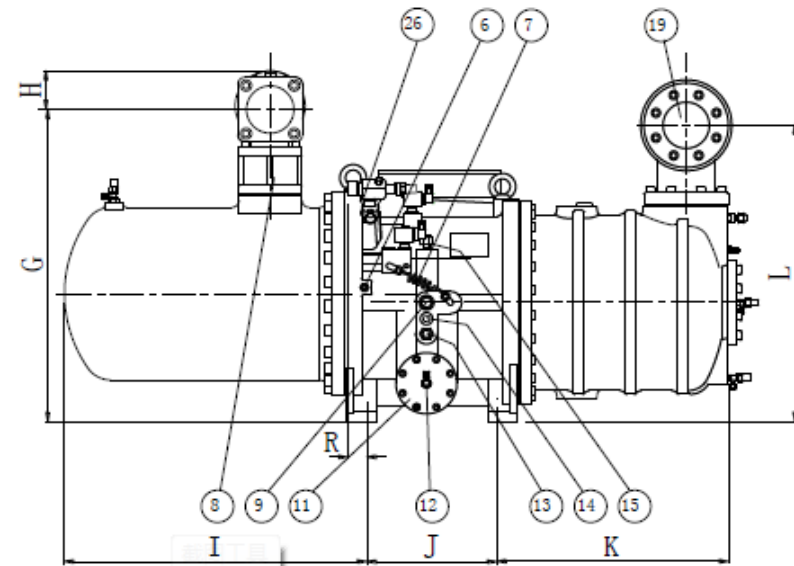
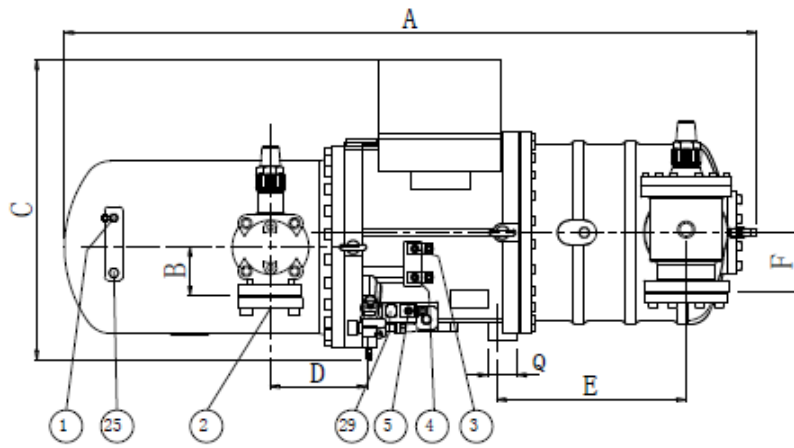

No.	Part Name	Remark	No.	Part Name	Remark
1	High pressure side angle valve	1/4" Flare	16	Low pressure side angle valve	1/4" Flare
2	Discharge flange		17	Refrigerant filling valve	1/4" Flare
3	Solenoid valve	50% loading	18	Motor liquid injection port	1/2" Flare
4	Solenoid valve	75% loading	19	Suction flange	
5	Solenoid valve	25% loading	20	Terminal box	
6	Injection port	3/8" Flare	21	Cleaning cover flange	
7	Capillary		22	Drain valve	
8	Check valve		23	Oil level switch	
9	Oil sight glass		24	Discharge temp sensor	110C
10	Oil heater	300w	25	Plug	
11	Oil filter		26	ECO stop valve	
12	Connector for pressure switch		27	Oil sight glass	
13	Oil outlet	3/4" Flare	28	Overflow hole	Optional
14	Oil block pin	Optional	29	Cover	
15	Oil inlet	3/4" Flare			

10.2 RC2-100~930D-P Drawing

RC2-100/140D-P Drawing

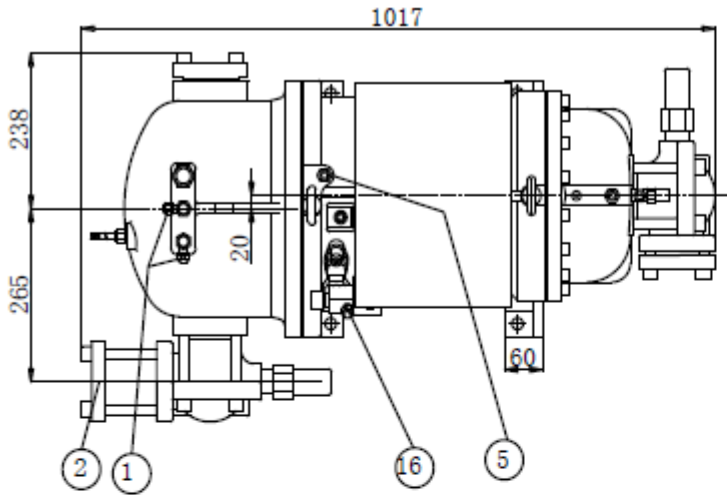

No.	Part Name	Remark	No.	Part Name	Remark
1	High pressure side angle valve	1/4" Flare	11	Motor liquid injection port	1/2" Flare
2	Discharge flange	2"	12	Suction flange	2"
3	Solenoid valve	33% loading	13	Terminal box	
4	Solenoid valve	66% loading	14	Cleaning cover flange	
5	Injection port	3/8" Flare	15	Discharge temp sensor	110C
6	Capillary		16	ECO stop valve	
7	Oil filter		17	Cover	
8	Oil inlet	3/8" Flare	18	Plug	
9	Low pressure side angle valve	1/4" Flare	19	Oil block pin	
10	Refrigerant filling valve	1/4" Flare	20	Oil outlet	3/8" Flare

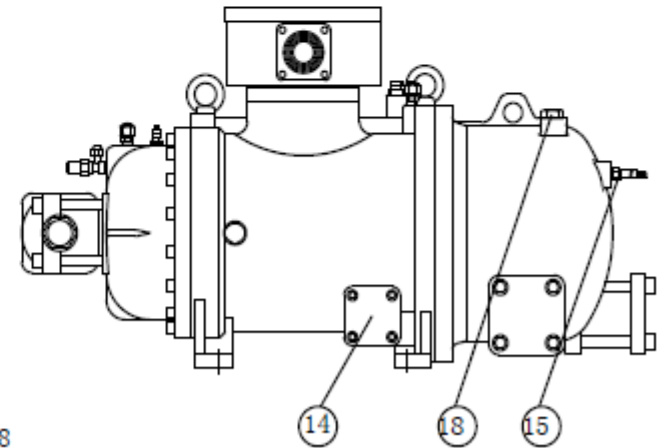
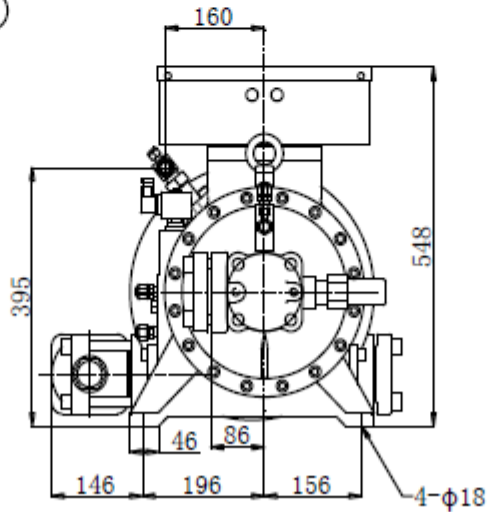
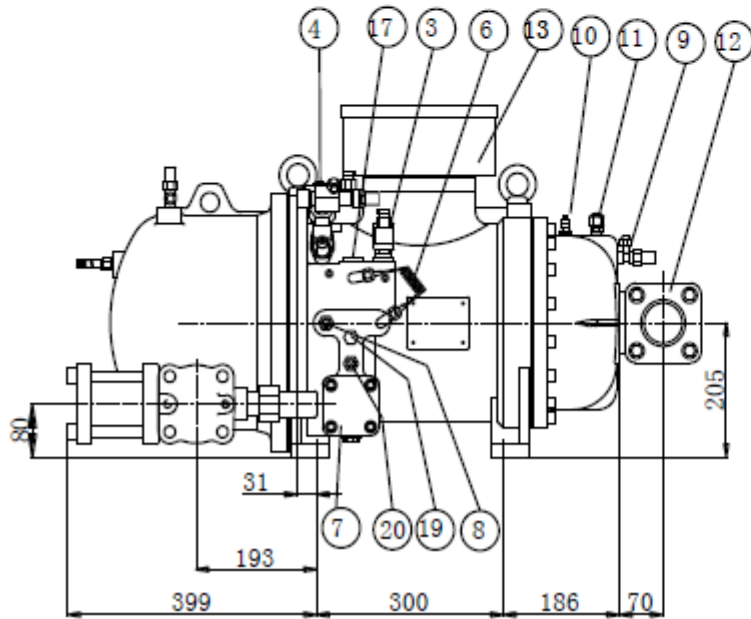

RC2-180D-P Drawing

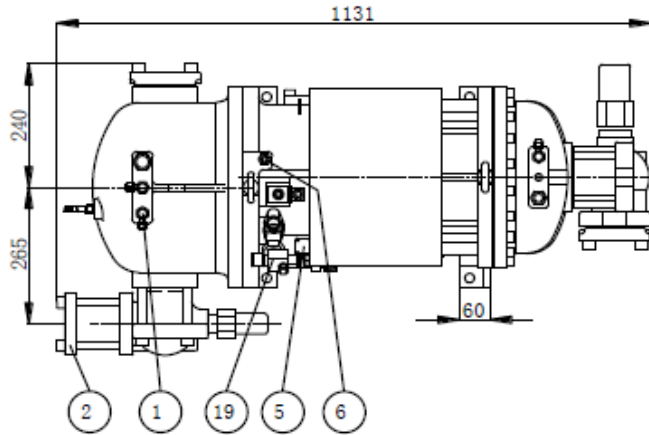

No.	Part Name	Remark	No.	Part Name	Remark
1	High pressure side angle valve	1/4" Flare	11	Oil outlet	3/8" Flare
2	Discharge flange	2"	12	Oil inlet	3/8" Flare
3	Solenoid valve	33% loading	13	Low pressure side angle valve	1/4" Flare
4	Solenoid valve	66% loading	14	Refrigerant filling valve	1/4" Flare
5	Cover		15	Motor liquid injection port	1/2" Flare
6	Injection port	3/8" Flare	16	Suction flange	2-1/2"
7	Capillary		17	Terminal box	
8	Discharge temp sensor	110C	18	Cleaning cover flange	
9	Plug		19	ECO stop valve	
10	Oil filter		20	Plug	
			21	Oil block pin	

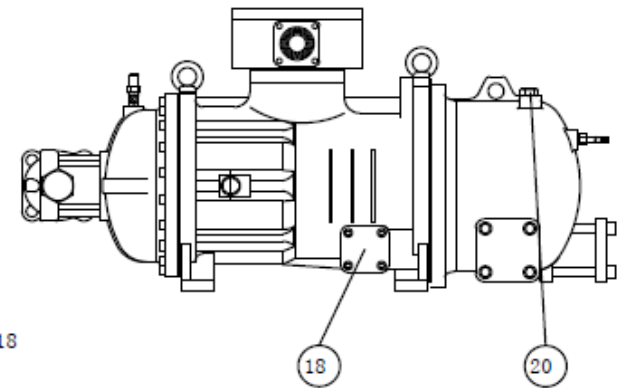
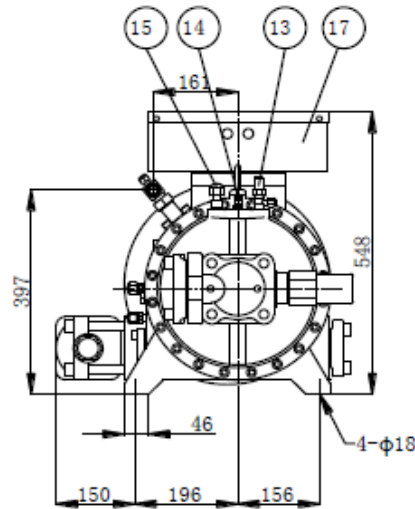
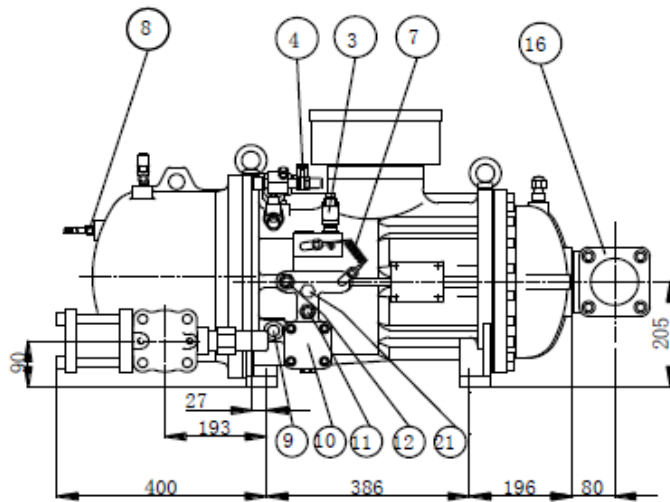

RC2-200~620D-P Drawing

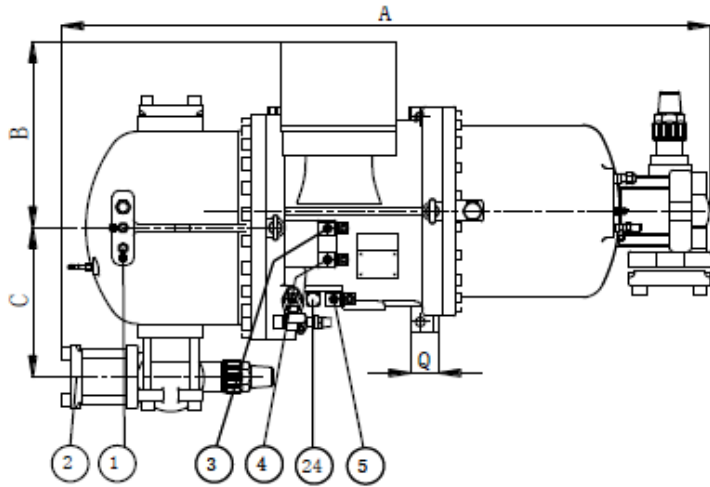

No.	Part Name	Remark	No.	Part Name	Remark
1	High pressure side angle valve	1/4" Flare	13	Oil block pin	
2	Discharge flange		14	Oil inlet	
3	Solenoid valve	50% loading	15	Low pressure side angle valve	1/4" Flare
4	Solenoid valve	75% loading	16	Refrigerant filling valve	1/4" Flare
5	Solenoid valve	25% loading	17	Motor liquid injection port	1/2" Flare
6	Injection port		18	Suction flange	
7	Capillary		19	Terminal box	
8	Discharge temp sensor	110C	20	Cleaning cover flange	
9	Plug		21	ECO stop valve	
10	Plug		22	Plug	
11	Oil filter		23	Cover	
12	Oil outlet				

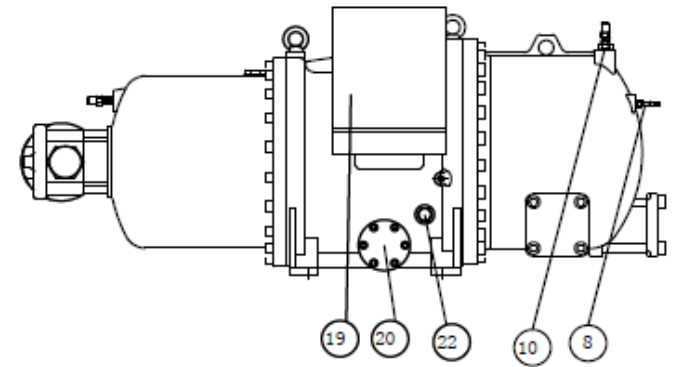
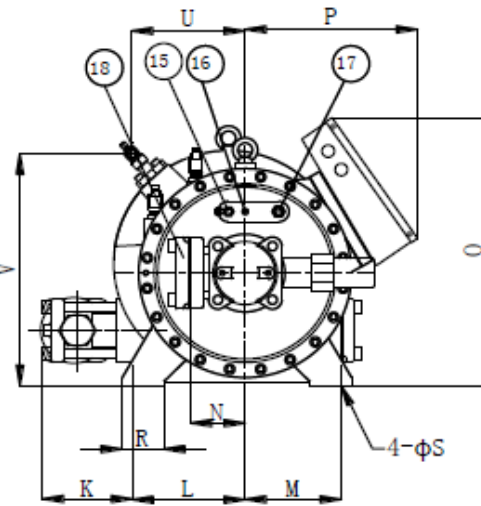
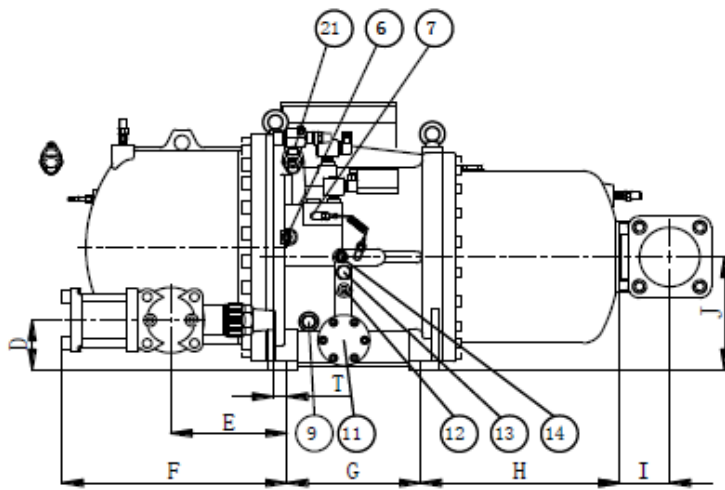

Model	RC2-200~620D-P (Horizontal suction port) Dimension																					
	A	B	C	D	E	F	G	H	I	J	K	L	M	N	O	P	Q	R	S	T	U	V
RC2-200D-P	1188	375	283	103	218	408	228	386	82	225	131	225	225	96	589	359	55	48	18	36	206	461
RC2-230/260D-P	1300	400	326	118	241	452	251	399	97	257	169	240	240	107	622	386	55	48	18	19	223	523
RC2-300D-P	1334	400	326	118	241	452	285	399	97	257	169	240	240	107	622	386	55	48	18	37	224	523
RC2-310D-P	1352	400	326	118	241	452	251	444	97	257	169	240	240	107	622	386	55	48	18	37	224	523
RC2-340/370D-P	1407	400	326	118	241	452	285	447	103	257	169	240	240	132	622	386	55	48	18	37	224	523
RC2-410D-P	1463	448	365	122	277	517	288	433	103	275	220	270	230	132	652	408	70	100	22	46	271	567
RC2-470D-P	1496	448	365	122	277	517	320	433	103	275	220	270	230	132	652	408	70	100	22	43	271	567
RC2-510D-P	1515	490	365	122	277	517	288	484	103	275	220	270	230	132	638	450	70	100	22	46	271	567
RC2-550D-P	1534	490	365	126	272	512	320	477	103	280	220	270	230	132	642	450	70	100	22	35	399	392
RC2-580D-P	1534	490	365	122	277	517	320	484	103	275	220	270	230	132	638	450	70	100	22	46	275	570
RC2-620D-P	1819	490	379	140	331	615	320	525	220	280	251	270	230	161	642	450	70	100	22	35	399	392

Model	RC2-620~930D-P (Vertical suction port) Dimension																				
	A	B	C	D	E	F	G	H	I	J	K	L	M	N	O	P	Q	R	S	T	U
RC2-620D-P	1657	490	379	510	161	140	331	615	320	623	738	124	251	270	230	642	450	70	35	399	392
RC2-710D-P	1710	505	379	515	161	185	346	630	353	628	808	124	250	270	230	682	465	80	52	259	634
RC2-790/830D-P	1805	505	379	515	161	185	346	630	418	628	808	124	250	270	230	682	465	80	8	236	606
RC2-930D-P	1852	509	379	585	161	185	346	630	418	698	808	124	250	270	230	682	465	80	8	236	606

RC2-620~930D-P Drawing

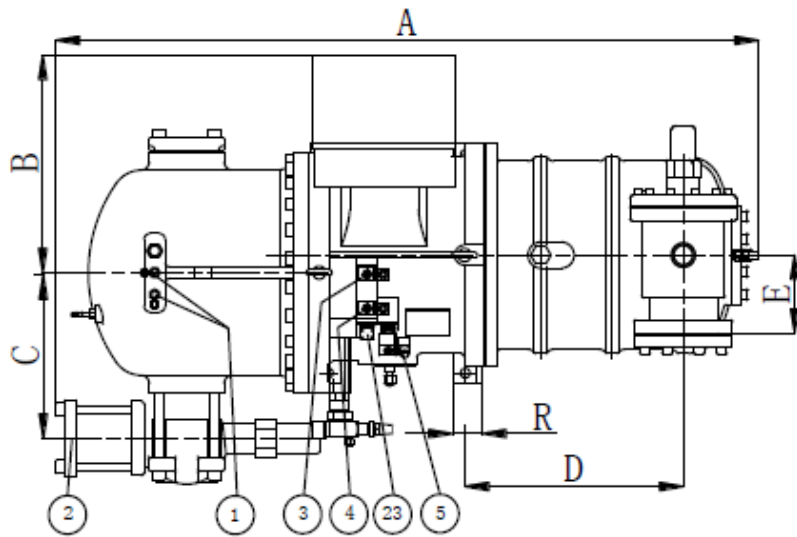

No.	Part Name	Remark	No.	Part Name	Remark
1	High pressure side angle valve	1/4" Flare	13	Oil block pin	
2	Discharge flange		14	Oil inlet	
3	Solenoid valve	50% loading	15	Low pressure side angle valve	1/4" Flare
4	Solenoid valve	75% loading	16	Refrigerant filling valve	1/4" Flare
5	Solenoid valve	25% loading	17	Motor liquid injection port	1/2" Flare
6	Injection port	3/8" Flare	18	Suction flange	
7	Capillary		19	Terminal box	
8	Discharge temp sensor	110C	20	Cleaning cover flange	
9	Oil sight glass		21	ECO stop valve	
10	Plug		22	Plug	
11	Oil filter		23	Cover	
12	Oil outlet				

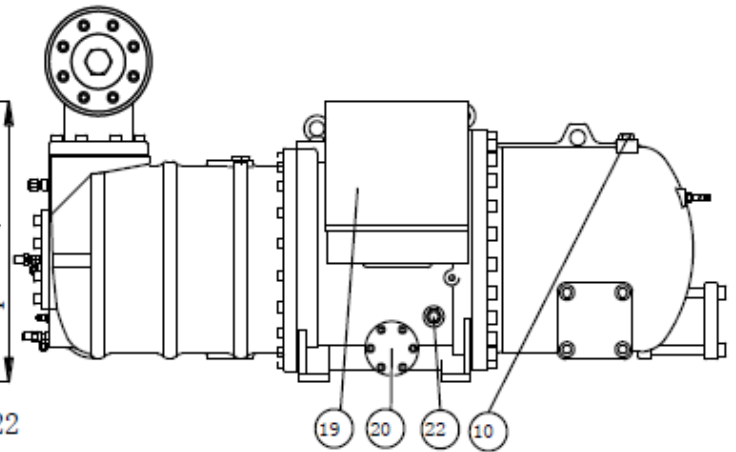
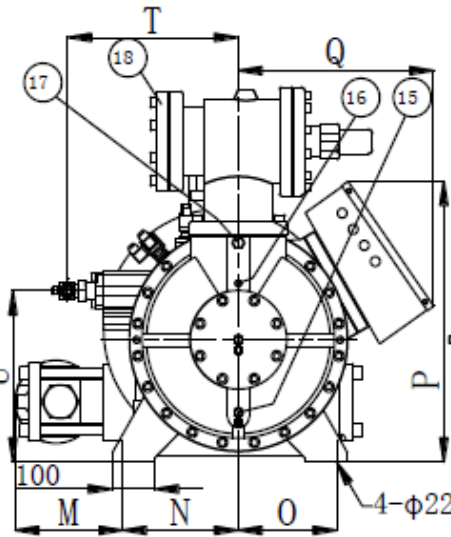
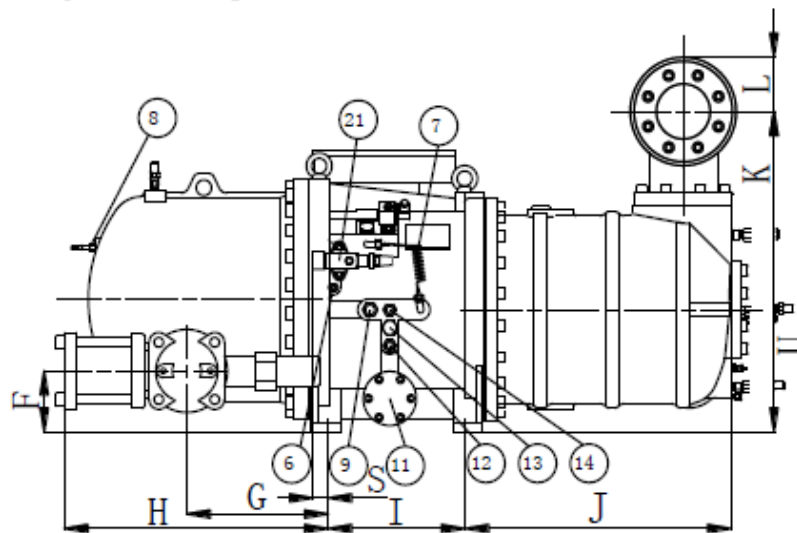

11.Connector Size

11.1 Connector size of single model

Model	Discharge	Copper	Steel	Suction	Copper	Steel	ECO stop valve	Oil return port	Oil injection port	Motor liquid injection port
RC2-100D-S	1-1/2"Flange	Φ42	Φ49.3	2"Flange	Φ55	Φ61.3	7/8"Flare (22.3)	3/8"Flare (9.7)	3/8"Flare (9.7)	1/2"Flare (12.8)
RC2-140D-S	1-1/2"Flange			2"Flange			7/8"Flare (22.3)	3/8"Flare (9.7)	3/8"Flare (9.7)	1/2"Flare (12.8)
RC2-180D-S	1-1/2"Flange			1/2"Flange	Φ68	Φ77.2	7/8"Flare (22.3)	3/8"Flare (9.7)	3/8"Flare (9.7)	1/2"Flare (12.8)
RC2-200D-S	1-1/2"Flange			1/2"Flange			7/8"Flare (22.3)	5/8"Flare (16)	3/8"Flare (9.7)	1/2"Flare (12.8)
RC2-230D-S	2"Flange	Φ55	Φ61.3	3"Flange	Φ80.5	Φ90.2	7/8"Flare (22.3)	5/8"Flare (16)	3/8"Flare (9.7)	1/2"Flare (12.8)
RC2-260D-S	2"Flange			3"Flange			7/8"Flare (22.3)	5/8"Flare (16)	3/8"Flare (9.7)	1/2"Flare (12.8)
RC2-300D-S	2"Flange			3"Flange			1 1/8"Flare (28.8)	5/8"Flare (16)	3/8"Flare (9.7)	1/2"Flare (12.8)
RC2-310D-S	2"Flange			3"Flange			1 1/8"Flare (28.8)	5/8"Flare (16)	3/8"Flare (9.7)	1/2"Flare (12.8)
RC2-340D-S	2-1/2"Flange	Φ68	Φ77.2	4"Flange	Φ93	Φ110	1 1/8"Flare (28.8)	5/8"Flare (16)	3/8"Flare (9.7)	1/2"Flare (12.8)
RC2-370D-S	2-1/2"Flange			4"Flange			1 1/8"Flare (28.8)	5/8"Flare (16)	3/8"Flare (9.7)	1/2"Flare (12.8)
RC2-410D-S	2-1/2"Flange			4"Flange			1 1/8"Flare (28.8)	5/8"Flare (16)	3/8"Flare (9.7)	1/2"Flare (12.8)
RC2-470D-S	2-1/2"Flange			4"Flange			1 1/8"Flare (28.8)	5/8"Flare (16)	3/8"Flare (9.7)	1/2"Flare (12.8)
RC2-510D-S	3"Flange	Φ80.5	Φ90.2	4"Flange	Φ106	Φ135	1 1/8"Flare (28.8)	5/8"Flare (16)	3/8"Flare (9.7)	1/2"Flare (12.8)
RC2-550D-S	3"Flange			4"Flange			1 3/8"Flare (35.2)	5/8"Flare (16)	3/8"Flare (9.7)	1/2"Flare (12.8)
RC2-580D-S	3"Flange			4"Flange			1 3/8"Flare (35.2)	5/8"Flare (16)	3/8"Flare (9.7)	1/2"Flare (12.8)
RC2-620D-S	3"Flange			5"Flange			1 3/8"Flare (35.2)	5/8"Flare (16)	3/8"Flare (9.7)	1/2"Flare (12.8)
RC2-710D-S	4"Flange	Φ93	Φ110	5"Flange	Φ106	Φ135	1 3/8"Flare (35.2)	3/4"Flare (19.2)	3/8"Flare (9.7)	1/2"Flare (12.8)
RC2-790D-S	4"Flange			5"Flange			1 3/8"Flare (35.2)	3/4"Flare (19.2)	3/8"Flare (9.7)	1/2"Flare (12.8)
RC2-830D-S	4"Flange			5"Flange			1 3/8"Flare (35.2)	3/4"Flare (19.2)	3/8"Flare (9.7)	1/2"Flare (12.8)
RC2-930D-S	4"Flange			5"Flange			1 3/8"Flare (35.2)	3/4"Flare (19.2)	3/8"Flare (9.7)	1/2"Flare (12.8)

11.2 Connector size of model in parallel connection

Model	Discharge	Copper	Steel	Suction	Copper	Steel	ECO stop valve	Oil return port	Oil injection port	Motor liquid injection port
RC2-100D-P	2"Flange	Φ55	Φ61.3	2"Flange	Φ55	Φ61.3	7/8"Flare (22.3)	3/8"Flare (9.7)	3/8"Flare (9.7)	1/2"Flare (12.8)
RC2-140D-P	2"Flange			2"Flange			7/8"Flare (22.3)	3/8"Flare (9.7)	3/8"Flare (9.7)	1/2"Flare (12.8)
RC2-180D-P	2"Flange			-1/2"Flang	Φ68	Φ77.2	7/8"Flare (22.3)	3/8"Flare (9.7)	3/8"Flare (9.7)	1/2"Flare (12.8)
RC2-200D-P	2"Flange			-1/2"Flang			7/8"Flare (22.3)	5/8"Flare (16)	3/8"Flare (9.7)	1/2"Flare (12.8)
RC2-230D-P	2-1/2"Flange	Φ68	Φ77.2	3"Flange	Φ80.5	Φ90.2	7/8"Flare (22.3)	5/8"Flare (16)	3/8"Flare (9.7)	1/2"Flare (12.8)
RC2-260D-P	2-1/2"Flange			3"Flange			7/8"Flare (22.3)	5/8"Flare (16)	3/8"Flare (9.7)	1/2"Flare (12.8)
RC2-300D-P	2-1/2"Flange			3"Flange			1 1/8"Flare (28.8)	5/8"Flare (16)	3/8"Flare (9.7)	1/2"Flare (12.8)
RC2-310D-P	2-1/2"Flange			3"Flange			1 1/8"Flare (28.8)	5/8"Flare (16)	3/8"Flare (9.7)	1/2"Flare (12.8)
RC2-340D-P	2-1/2"Flange			4"Flange	Φ93	Φ110	1 1/8"Flare (28.8)	5/8"Flare (16)	3/8"Flare (9.7)	1/2"Flare (12.8)
RC2-370D-P	2-1/2"Flange			4"Flange			1 1/8"Flare (28.8)	5/8"Flare (16)	3/8"Flare (9.7)	1/2"Flare (12.8)
RC2-410D-P	3"Flange			4"Flange			1 1/8"Flare (28.8)	5/8"Flare (16)	3/8"Flare (9.7)	1/2"Flare (12.8)
RC2-470D-P	3"Flange			4"Flange			1 1/8"Flare (28.8)	5/8"Flare (16)	3/8"Flare (9.7)	1/2"Flare (12.8)
RC2-510D-P	3"Flange	Φ80.5	Φ90.2	4"Flange			1 1/8"Flare (28.8)	5/8"Flare (16)	3/8"Flare (9.7)	1/2"Flare (12.8)
RC2-550D-P	3"Flange			4"Flange			1 3/8"Flare (35.2)	5/8"Flare (16)	3/8"Flare (9.7)	1/2"Flare (12.8)
RC2-580D-P	3"Flange			4"Flange	1 3/8"Flare (35.2)	5/8"Flare (16)	3/8"Flare (9.7)	1/2"Flare (12.8)		
RC2-620D-P	4"Flange			5"Flange	1 3/8"Flare (35.2)	5/8"Flare (16)	3/8"Flare (9.7)	1/2"Flare (12.8)		
RC2-710D-P	4"Flange	Φ93	Φ110	5"Flange	Φ106	Φ135	1 3/8"Flare (35.2)	3/4"Flare (19.2)	3/8"Flare (9.7)	1/2"Flare (12.8)
RC2-790D-P	4"Flange			5"Flange			1 3/8"Flare (35.2)	3/4"Flare (19.2)	3/8"Flare (9.7)	1/2"Flare (12.8)
RC2-830D-P	4"Flange			5"Flange			1 3/8"Flare (35.2)	3/4"Flare (19.2)	3/8"Flare (9.7)	1/2"Flare (12.8)
RC2-930D-P	4"Flange			5"Flange			1 3/8"Flare (35.2)	3/4"Flare (19.2)	3/8"Flare (9.7)	1/2"Flare (12.8)