

Diameter:

500 mm

R13_-5030H_-4T2-70101



Fan with guard grill

Airflow Direction	Type	Code	Weight (kg)
Sucking	R13R-5030HA-4T2-70101	0313-4-1038	12.5
Blowing	R13R-5030HP-4T2-70101	On request	

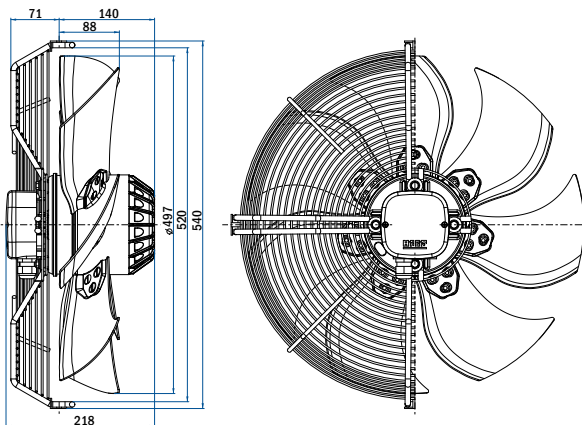

Fan with plate

Airflow Direction	Type	Code	Weight (kg)
Sucking	R13P-5030HA-4T2-70101	0313-4-1028	18.0
Blowing	R13P-5030HP-4T2-70101	On request	

Fan without guard grill

Airflow Direction	Type	Code	Weight (kg)
Sucking	R13E-5030HA-4T2-70101	0313-4-1068	10.1
Blowing	R13E-5030HP-4T2-70101	On request	

Nominal data according to standard EN 60335:	
Phase	3~
Nominal voltage	400 V
Frequency	50 Hz
Speed	high/low
Rated power input	770/590 W
Rated current	1.6/0.96 A
Rated speed	1380/1165 RPM
Min. ambient temperature	-30 °C
Max. ambient temperature	55/65 °C
Sound power level A weighted	76/72 dB (A)
Connection	terminal box
Insulation class	155
Protection class	IP54

ErP data according to EU regulation 327/2011:	
Overall efficiency	31.1 %
Measurement category	A
Efficiency category	static
Efficiency grade N	40.2
Variable speed drive	NO
Power input	745 W
Air flow	6519 m ³ /h
Pressure drop	141 Pa
Speed	1390 RPM
Specific ratio	1.00

Aerodynamic characteristic

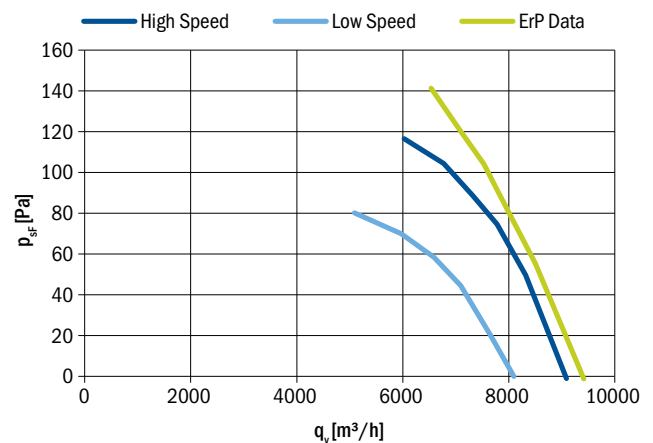

Fan characteristic measured in full bell mouth with guard grill.
ErP characteristic measured in full bell mouth without guard grill.

General notes	
Connection diagrams:	
Sucking	0301-1-0033 See section
Blowing	0301-1-0033 Connection diagrams
Guard grills & wall-plates	See section Accessories
Standards compliance	See introduction page