

**R13\_-5030H\_-4M-7075**

**Diameter:**

**500 mm**

**Nominal data according to standard EN 60335:**

Phase	1~
Nominal voltage	230 V
Frequency	50 Hz
Rated power input	780 W
Rated current	3.50 A
Rated speed	1370 RPM
Min. ambient temperature	-30 °C
Max. ambient temperature	60 °C
Sound power level A weighted	76 dB (A)
Condensator	16 µF/450 V
Connection	terminal box
Insulation class	155
Protection class	IP54

**ErP data according to EU regulation 327/2011:**

Overall efficiency	29.4 %
Measurement category	A
Efficiency category	static
Efficiency grade N	36.4
Variable speed drive	NO
Power input	771 W
Air flow	6829 m³/h
Pressure drop	125 Pa
Speed	1336 RPM
Specific ratio	1.00

**Aerodynamic characteristic**

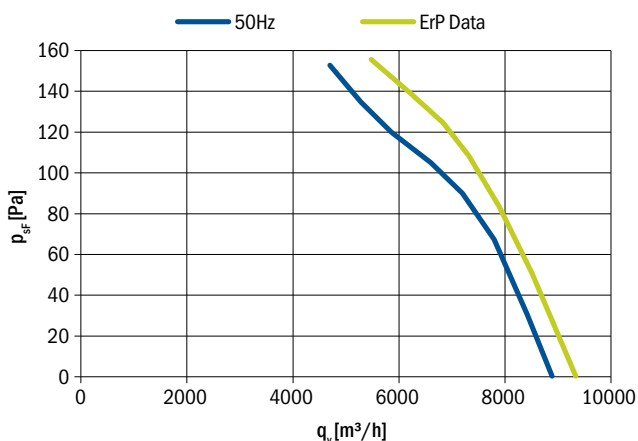

Fan characteristic measured in short bell mouth with guard grill.  
ErP characteristic measured in full bell mouth without guard grill.

**General notes**

Connection diagrams:			
Sucking	0301-1-0035	See section	
Blowing	0301-1-0029	Connection diagrams	
Guard grills & wall-plates	See section Accessories		
Standards compliance	See introduction page		



**Fan with guard grill**

Airflow Direction	Type	Code	Weight (kg)
Sucking	R13R-5030HA-4M-7075	0313-4-1081	13.1
Blowing	R13R-5030HP-4M-7075	On request	

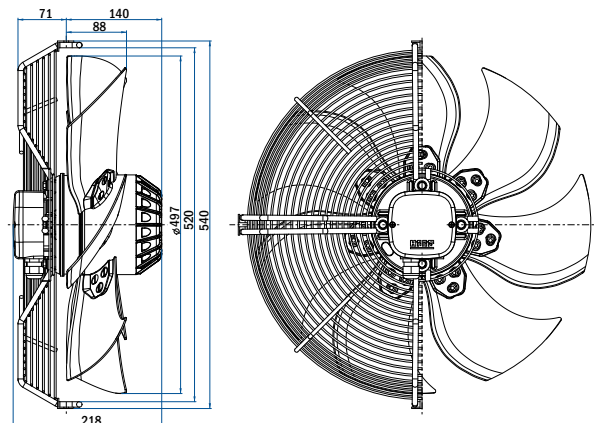

**Fan with plate**

Airflow Direction	Type	Code	Weight (kg)
Sucking	R13P-5030HA-4M-7075	0313-4-1120	18.6
Blowing	R13P-5030HP-4M-7075	On request	

**Fan without guard grill**

Airflow Direction	Type	Code	Weight (kg)
Sucking	R13E-5030HA-4M-7075	0313-4-1121	10.7
Blowing	R13E-5030HP-4M-7075	On request	