

Diameter: **630 mm**

R14_-63AP_-ES60B-01A04



Nominal data according to standard IEC 60034 (max. load):	
Phase	1~
Nominal voltage	230 V
Nominal voltage range	200-277 V
Frequency	50-60 Hz
Input power	620 W
Input current	2.7 A
Nominal speed	1000 RPM
Min. ambient temperature	-25 °C
Protection class	IP54
Insulation class	130

ErP data according to EU regulation 327/2011:	
Overall efficiency	50.5 %
Measurement category	A
Efficiency category	static
Efficiency grade N	57.9
Variable speed drive	INTEGRATED
Power input	0.67 kW
Air flow	8955 m ³ /h
Pressure drop	128 Pa
Rotational speed	1008 RPM
Specific ratio	1.00

General notes	
Connection diagram: 0302-0-1005	See section Connection diagrams
Guard grills & wall-plates	See section Accessories
Standards compliance	See introduction page

Dimensions and fan ordering information



Type: R14R-63APS-ES60B-01A04
Code: 0314-4-0047
Weight: 14.4 kg

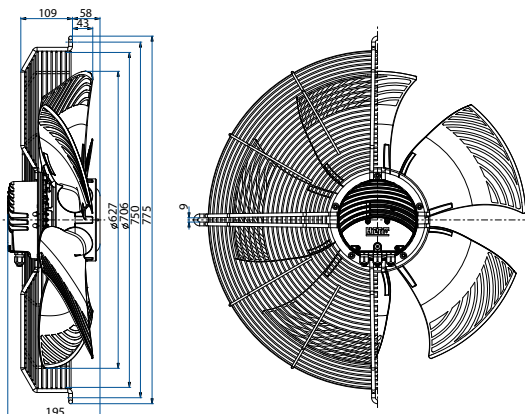

Type: R14P-63APS-ES60B-01A04
Code: 0314-4-0048
Weight: 23.1 kg

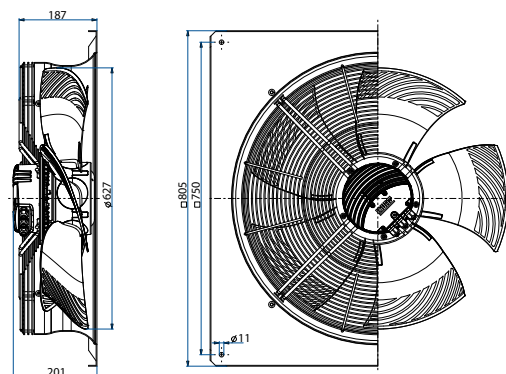

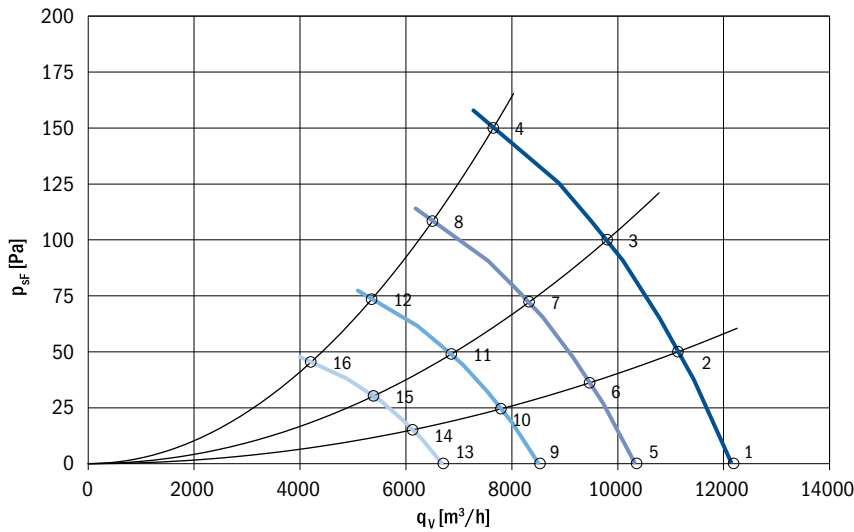

Aerodynamic characteristic:

- measured in full bell mouth without guard grill
- installation category A according to ISO 5801

Sound power level:

- measured on pressure side
- fan mounted in full bell mouth without guard grill
- measured according to ISO 3741; installation type A

The values given may vary according to actual installation in the unit.

Definition of symbols

- U [V]** Supply voltage
- f [Hz]** Frequency
- n [RPM]** Fan speed
- qv [m³/h]** Air flow
- psf [Pa]** Pressure drop
- Pe [W]** Power input
- I [A]** Current
- Lwa [dB (A)]** Sound power level A weighted
- Ta max [°C]** Max. ambient temperature

	U [V]	f [Hz]	n [RPM]	qv [m³/h]	psf [Pa]	Pe [W]	I [A]	Lwa out [dB (A)]	Ta max [°C]
1	230	50	1000	12190	0	480	2.07	71	60
2	230	50	1000	11140	50	571	2.47	68	60
3	230	50	1000	9800	100	640	2.76	69	60
4	230	50	1000	7650	150	713	3.07	70	60
5	230	50	850	10362	0	295	1.27	68	60
6	230	50	850	9469	36	351	1.52	65	60
7	230	50	850	8330	72	393	1.69	66	60
8	230	50	850	6503	108	438	1.89	67	60
9	230	50	700	8533	0	165	0.71	64	60
10	230	50	700	7798	25	196	0.85	61	60
11	230	50	700	6860	49	220	0.95	62	60
12	230	50	700	5355	74	245	1.05	63	60
13	230	50	550	6705	0	80	0.34	58	60
14	230	50	550	6127	15	95	0.41	55	60
15	230	50	550	5390	30	106	0.46	56	60
16	230	50	550	4208	45	119	0.51	57	60



Type: R14R-63APB-ES60B-01A04
Code: 0314-4-0049
Weight: 14.4 kg

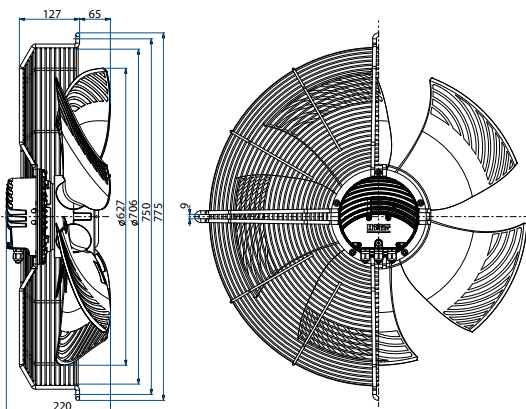

Type: R14P-63APB-ES60B-01A04
Code: 0314-4-0050
Weight: 23.1 kg

