



Küba SG commercial





Küba SG commercial: Specific advantages

High performance air cooler for commercial applications with a large scope and complete capacity spectrum.

Draw-through fans guide the air flow evenly through the heat exchanger, enabling the maximum use of the air cooler surface.

Q_0 0,7 — 32 kW



Goods are cooled down more quickly with optimum air distribution, thanks to the patented, standard air straightener.

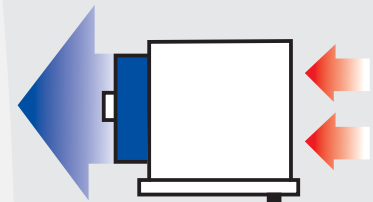

The Küba SG commercial can cope with the most difficult environmental demands due to its comprehensive standard equipment and numerous alternative versions as well as accessories.

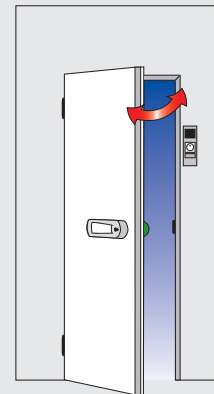

Precision in the cold storage room has a name: Küba SG commercial

The Küba SG commercial sets the worldwide standard for all high performance Air Coolers in cold and frozen Chill Rooms.

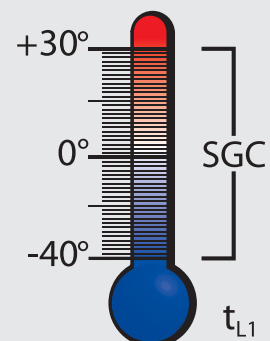



Küba SG commercial: Specific advantages

What are the effects of a long air throw range?

Grille

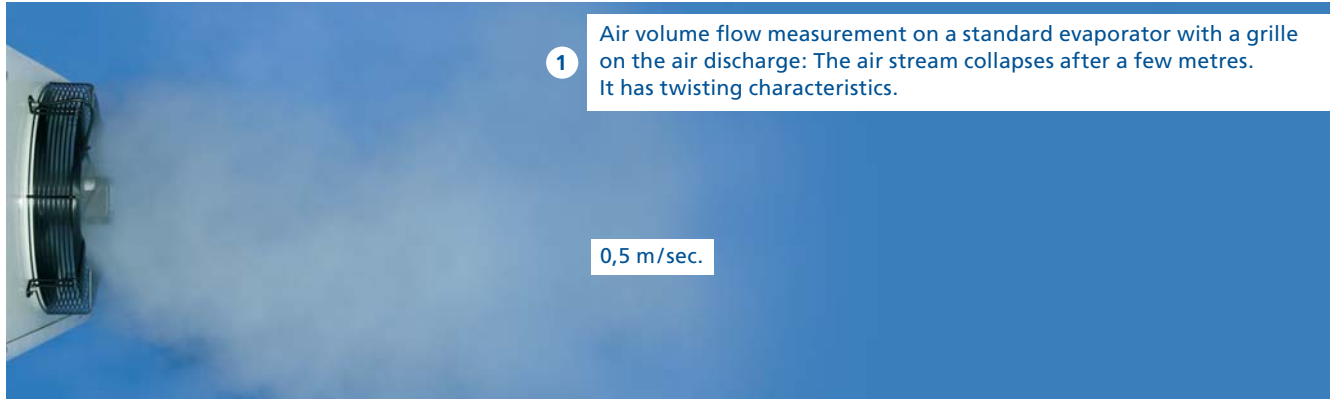

Grille and guide-wheel

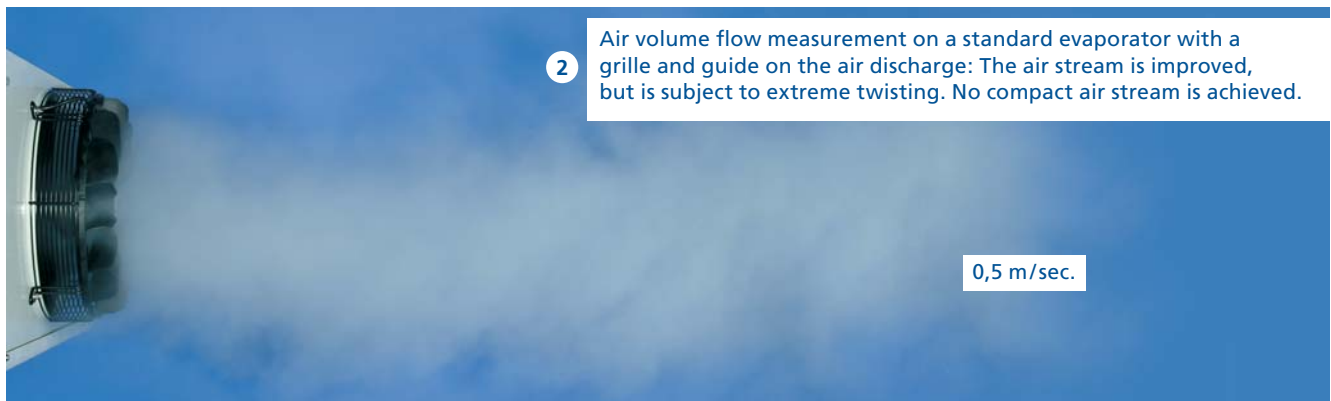

Küba air straightener

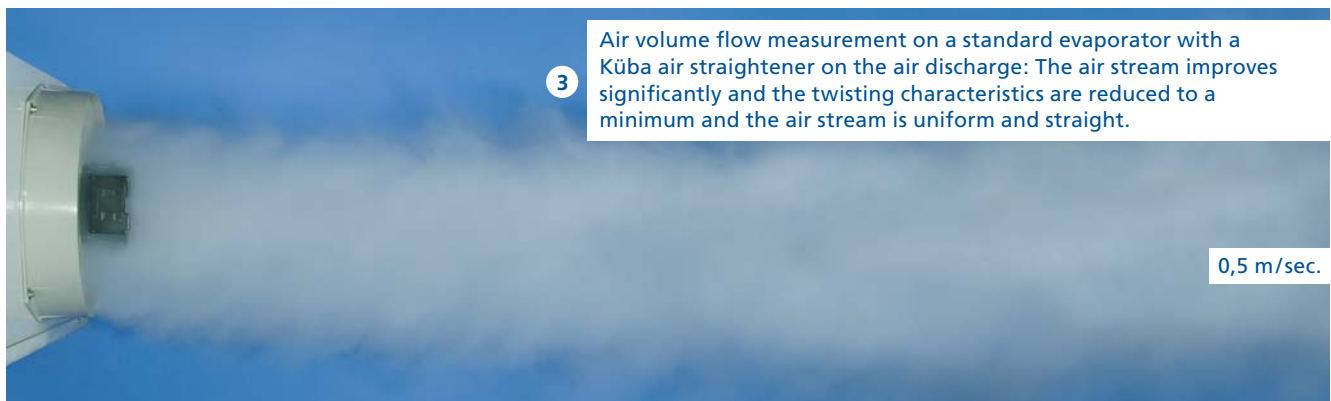

Air throw comparison at a nominal capacity of 5.95 kW





Küba SG commercial: Specific advantages

Goods stay at a uniform temperature due to improved air distribution

Refrigeration in large, long cold storage areas can be effected with Küba Air Coolers. Very long throw ranges can be achieved with the air straighteners. This allows the chilled air to reach the most remote corners of the cold storage area. In connection with the product specific stacking, room ventilation is trouble-free. Heat pockets are prevented.

Clear advantages are:

- Even air distribution
- Short cooling times
- Uniform product cooling
- No fluctuations in product temperatures
- Quality is retained

Küba Air Straighteners ➔ **short cooling times**

**Cooling curve comparison
Küba high performance SG Air Coolers**

Without Küba Air Straighteners

- Poor room ventilation
- Large differences in product temperatures: 6K
- Relatively long cooling times

With Küba Air Straighteners

- Better distribution of cooled air
- Products are cooled more evenly: 1K
- Short cooling times
- Lower temperature difference (DT1)
- Lower operational costs

Key:

- t_0 = Evaporating temperature at coil outlet
- t_{0h} = Superheated temperature at coil outlet
- t_{L1} = Air entry temperature into the air cooler

Küba Air Straighteners ➔ **More uniform product temperatures**

**Uniform product temperatures:
Documented by measurement series in cold storage area**

To perform the cooling curve comparison, a cold storage area was filled with stacks of goods. The measuring points 1-11 show the development of the product core temperature in relation to cooling time.

The starting conditions were identical in both trials – entry temperature 24 °C. For the cooler without an Air straightener, the temperature difference in the stack of goods after 21 hours cooling time was 6K.

The Küba SG with Air straightener achieved the outstanding result of only a 1K temperature difference.

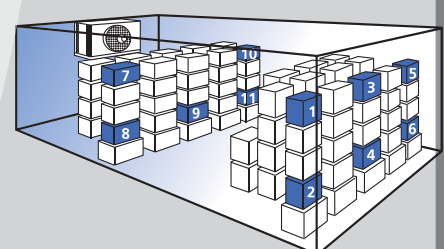
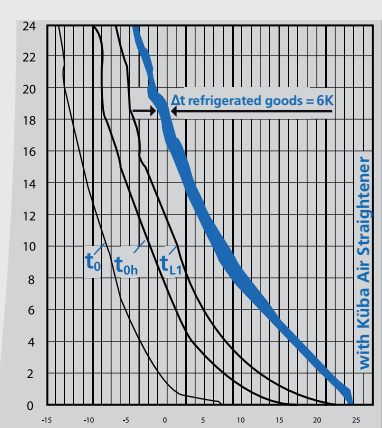
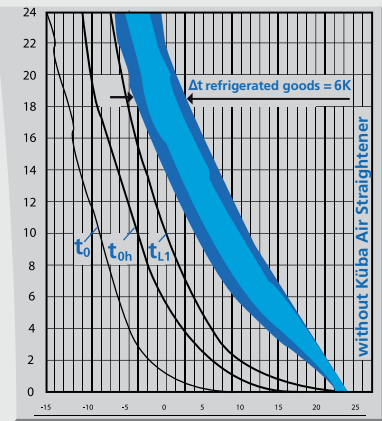
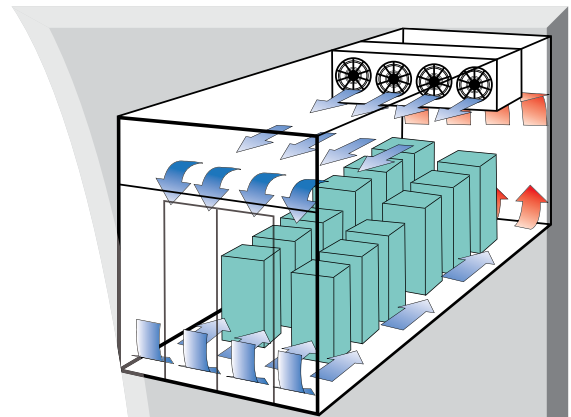



Construction

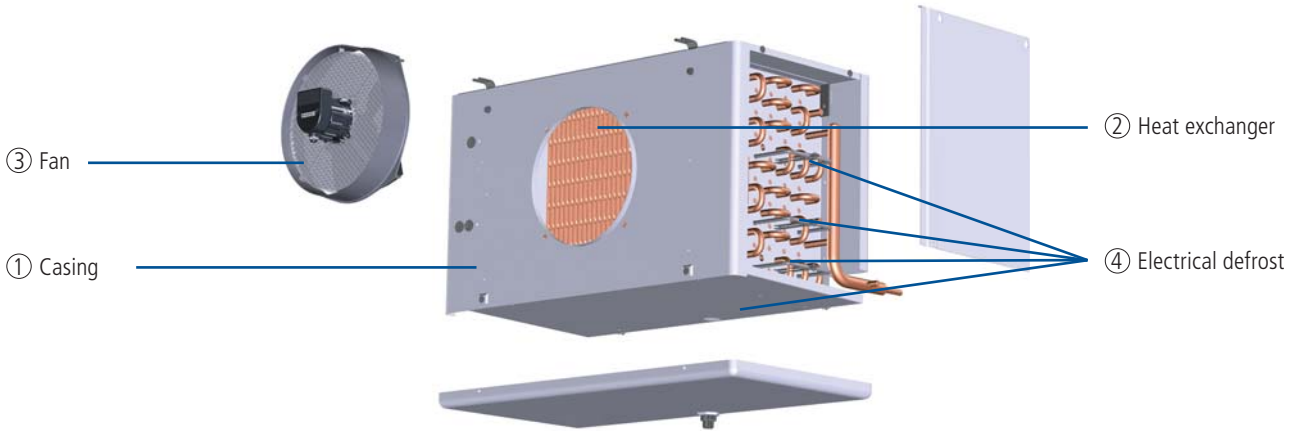

1. Casing

- Al-Stucco
- High-grade powder coating, papyrus white RAL 9018
 - Food quality
 - Easy to clean
 - Optimum corrosion protection
- Drip tray and side panels removable
- Stainless steel mounting material and brackets
- Plastic drain

2. Heat exchanger

- Fin spacing
 - SGA.C: 4,5mm
 - SGB.C: 7mm
 - SGL.C: 12mm
- Tube arrangement aligned, spacing 50 x 50 mm
- HFE® tube / fin system
- Tubing: Cu-special
- Fins: Al
- End plates: Al
- Küba-CAL® refrigerant distributor for multiple injection

3. Fans

- Ø250 to 500 mm
- In accordance with VDE specifications with built-in protector
- Application range: -40 °C bis +45 °C
- SG. 011 -083C: 230 ±10%V-1~, 50/60Hz
- SG.091 -103C: 400±10%V-3~, 50/60Hz
- Protection class IP44 in accordance with EN 60529
- Insulation class F in accordance with EN 60034
- Operating data can be found with Küba Select or in the technical data

• Optional Controller:	011-083	091-103
Phase control	<input checked="" type="checkbox"/>	<input checked="" type="checkbox"/>
Transformer	<input checked="" type="checkbox"/>	<input checked="" type="checkbox"/>
Delta / star	<input type="checkbox"/>	<input type="checkbox"/>
Frequency converter	<input type="checkbox"/>	<input checked="" type="checkbox"/>

⚠ Please observe the manufacturer's information.

Motor label data (max. allowable value +40°C)

	50 Hz			60 Hz		
	min ⁻¹	W	A	min ⁻¹	W	A
SG.011/021C	1300	38	0,17	1500	52	0,21
SG.031/041C	1300	90	0,40	1415	128	0,51
SG.051-081C	1360	210	0,95	1395	148	0,58
SG.091/101C	1400	450	1,00	1600	630	1,2



Note:
4 and 4 motor models on request

4. Electrical defrost

- 230 ±10% V-1~ or 400 ±10% V-3~ -Y
- Heaters with CrNi steel sleeve
- Vapour-tight connections
- Connector cable 1.5 mm² x 1000 mm
- Designed to defrost the fin package quickly and evenly
- To prevent vapour build-up and to accomplish heat transfer with almost no loss, the heaters are mounted in special expanded tube sleeves
- Wired ready for connection to the connection box in accordance with VDE specifications



Refrigerant / coolant

- Can be used with all HFC refrigerants, performance data can be found with Küba Select (Product Selection Software)
- For water / brine circulation choose your air cooler with Küba Select
- For CO₂ operation and for NH₃ applications immediate selection with Küba Select is possible; or ask our technical staff in sales



The performance data in the Q_v charts refer to the combination of materials: tubes, Cu / fins, Al.

Küba Blue Line
Freshness that lasts longer



Technical data (R404A)

SGA...C



Nomenclature

Standard

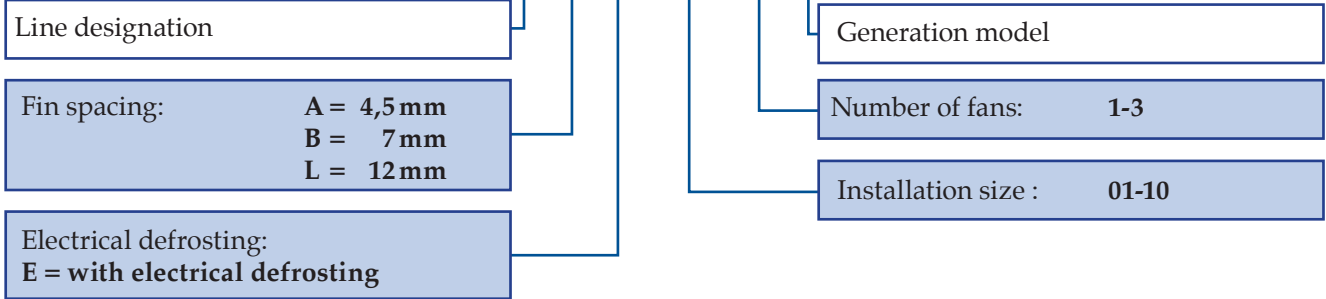

Model	Rating Q ₀ at 50 Hz		Surface m ²	Air flow m ³ /h	Air throw m	Tube volume dm ³	Connections			Fans (operating values at 50 Hz)				
	t ₁₁ ±0 °C DT1 = 8K	t ₁₁ -18 °C DT1 = 7K					Inlet Ø mm	Outlet Ø mm	Blade Ø mm	Type of current	min ⁻¹	W	A	
SGA 011C	⊕	1,00	0,79	7,3	620	7	1,3	10	15	250		1301	32	0,15
SGA 021C	⊕	1,23	0,97	9,7	520	7	1,3	10	15	250		1301	32	0,15
SGA 031C	⊕	1,98	1,57	12,5	1060	10	2,1	10	15	300	230±10%	1295	86	0,38
SGA 041C	⊕	2,19	1,73	16,6	970	10	2,8	10	15	300	V-1~	1295	86	0,38
SGA 051C	⊕	3,45	2,74	23,1	1620	13	3,8	10	22	400	50/60 Hz	1307	105	0,46
SGA 061C	⊕	3,81	3,03	28,7	1600	13	4,8	10	22	400		1307	105	0,46
SGA 071C	⊕	5,69	4,52	34,5	2610	19	5,7	10*	22	400		1362	205	0,90
SGA 081C	⊕	6,73	5,34	51,5	2640	19	8,8	10*	28	400	230/400	1362	205	0,90
SGA 091C	⊕	9,42	7,49	61,8	4010	23	10,6	10*	28	500	±10%V-3~	1417	360	0,86
SGA 101C	⊕	10,80	8,57	82,3	4300	23	13,6	12*	35	500	50/60 Hz	1417	360	0,86
SGA 012C	⊕⊕	1,99	1,57	14,5	1240	11	2,3	10	15	250		1301	32	0,15
SGA 022C	⊕⊕	2,45	1,94	19,2	1040	11	3,1	10	18	250		1301	32	0,15
SGA 032C	⊕⊕	3,96	3,14	24,6	2120	14	3,9	10	18	300	230±10%	1295	86	0,38
SGA 042C	⊕⊕	4,38	3,47	33,0	1940	14	5,3	10	22	300	V-1~	1295	86	0,38
SGA 052C	⊕⊕	6,91	5,48	45,7	3240	18	7,6	10*	28	400	50/60 Hz	1307	105	0,46
SGA 062C	⊕⊕	7,62	6,05	57,1	3200	18	9,1	12*	28	400		1307	105	0,46
SGA 072C	⊕⊕	11,37	9,02	68,5	5220	26	10,8	12*	35	400		1362	205	0,90
SGA 082C	⊕⊕	13,46	10,68	103,0	5280	26	16,6	15*	35	400	230/400	1362	205	0,90
SGA 092C	⊕⊕	18,86	14,98	123,0	8020	33	19,8	15*	35	500	±10%V-3~	1417	360	0,86
SGA 102C	⊕⊕	21,60	17,16	164,0	8600	33	26,1	15*	42	500	50/60 Hz	1417	360	0,86
SGA 013C	⊕⊕⊕	2,99	2,36	21,5	1860	13	3,4	10	15	250		1301	32	0,15
SGA 023C	⊕⊕⊕	3,68	2,92	28,7	1560	13	4,5	10	22	250		1301	32	0,15
SGA 033C	⊕⊕⊕	5,94	4,70	37,0	3180	17	5,8	10	28	300	230±10%	1295	86	0,38
SGA 043C	⊕⊕⊕	6,57	5,20	49,2	2910	17	8,1	10*	28	300	V-1~	1295	86	0,38
SGA 053C	⊕⊕⊕	10,35	8,21	68,3	4860	22	11,1	12*	35	400	50/60 Hz	1307	105	0,46
SGA 063C	⊕⊕⊕	11,42	9,07	85,5	4800	22	13,1	12*	35	400		1307	105	0,46
SGA 073C	⊕⊕⊕	17,06	13,54	103,0	7830	32	16,2	15*	35	400		1362	205	0,90
SGA 083C	⊕⊕⊕	20,19	16,02	154,0	7920	32	24,6	22*	42	400	230/400	1362	205	0,90
SGA 093C	⊕⊕⊕	28,29	22,47	184,0	12000	40	29,6	22*	54	500	±10%V-3~	1417	360	0,86
SGA 103C	⊕⊕⊕	32,41	25,75	246,0	12900	40	38,5	22*	54	500	50/60 Hz	1417	360	0,86

* Multiple injection with direct expansion using Küba CAL® distributors. The cooler rating at 60 Hz is 10% higher on average due to the higher speed and higher air flow.



Q_v chart (EN328, R404A) SGA...C 4,5 mm

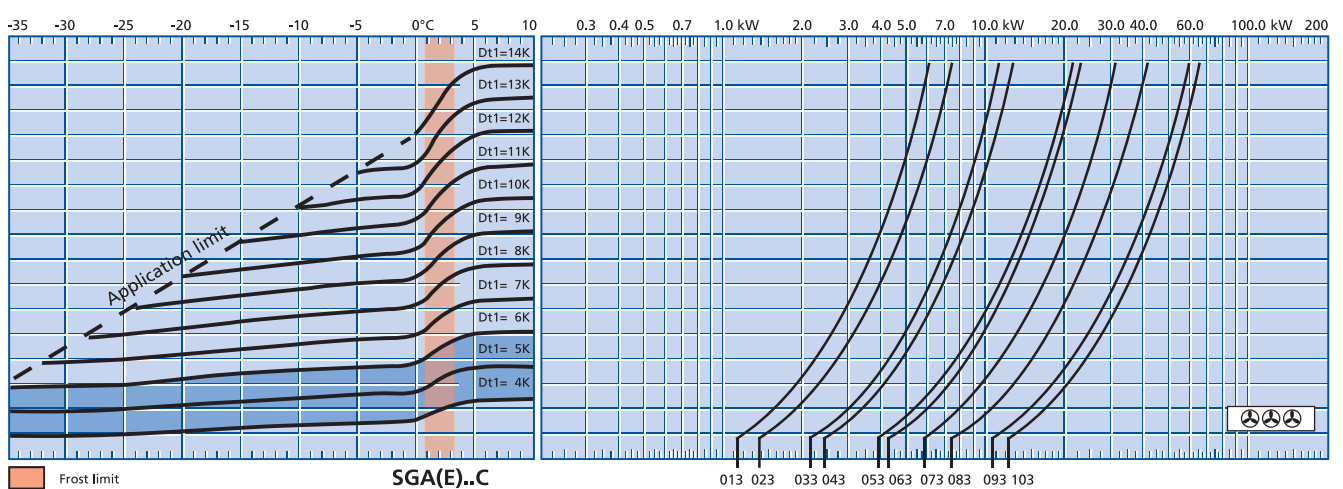
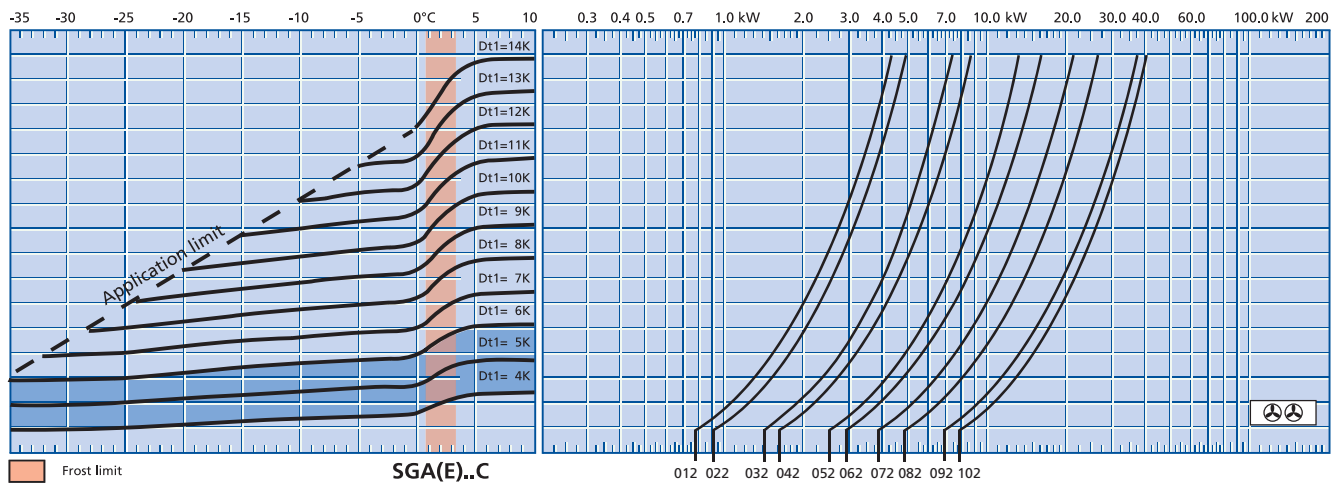
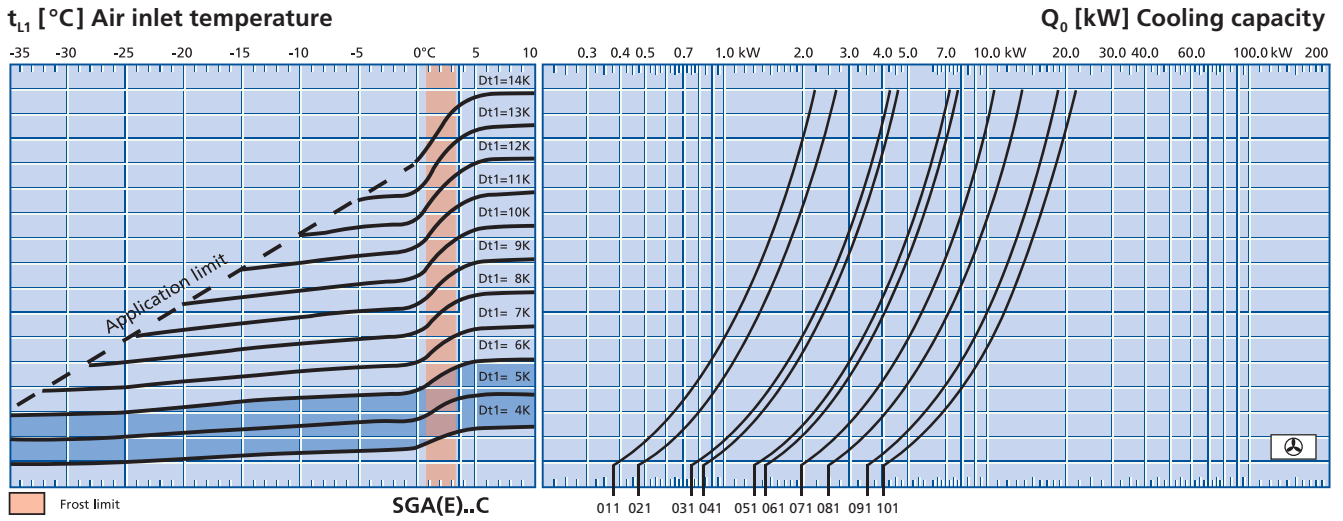

Q₀ = Cooling capacity
 t_{L1} = Air inlet temperature
 t₀ [°C] = Evaporating temperature (coil outlet)
 DT1 [K] = Temperature difference = t_{L1} - t₀ (°C)

DT1 = 4 K bis 6 K
 with electronic expansion valve

Example selection:
 For example and explanation, see the information section on p. 136.



Technical data (R404A)

SGB...C



Model		Rating Q ₀ at 50 Hz		Surface m ²	Air flow m ³ /h	Air throw m	Tube volume dm ³	Connections			Fans (operating values at 50 Hz)			
		t ₁₁ ±0 °C DT1 = 8K	t ₁₁ -18 °C DT1 = 7K					Inlet Ø mm	Outlet Ø mm	Blade Ø mm	Type of current	min ⁻¹	W	A
		kW	kW											
SGB 011C	⊕	0,91	0,72	4,9	700	8	1,3	10	15	250		1301	32	0,15
SGB 021C	⊕	1,13	0,90	6,5	640	8	1,3	10	15	250		1301	32	0,15
SGB 031C	⊕	1,74	1,37	8,2	1300	12	2,1	10	15	300	230±10%	1295	86	0,38
SGB 041C	⊕	2,00	1,59	11,1	1180	12	2,8	10	15	300	V-1~	1295	86	0,38
SGB 051C	⊕	2,91	2,31	15,2	1770	14	3,8	10	22	400	50/60 Hz	1307	105	0,46
SGB 061C	⊕	3,34	2,65	19,1	1760	14	4,8	10	22	400		1307	105	0,46
SGB 071C	⊕	4,81	3,81	22,8	2800	20	5,7	10*	22	400		1362	205	0,90
SGB 081C	⊕	5,98	4,74	34,1	2900	20	8,8	10*	28	400	230/400	1362	205	0,90
SGB 091C	⊕	8,42	6,69	41,0	4530	26	10,6	10*	28	500	±10%V-3~	1417	360	0,86
SGB 101C	⊕	9,50	7,54	54,5	4660	26	13,6	12*	35	500	50/60 Hz	1417	360	0,86
SGB 012C	⊕⊕	1,82	1,44	9,5	1400	12	2,3	10	15	250		1301	32	0,15
SGB 022C	⊕⊕	2,27	1,79	12,7	1280	12	3,1	10	18	250		1301	32	0,15
SGB 032C	⊕⊕	3,47	2,75	16,3	2600	17	3,9	10	18	300	230±10%	1295	86	0,38
SGB 042C	⊕⊕	4,00	3,17	21,7	2360	17	5,3	10	22	300	V-1~	1295	86	0,38
SGB 052C	⊕⊕	5,82	4,61	30,2	3540	19	7,6	10*	28	400	50/60 Hz	1307	105	0,46
SGB 062C	⊕⊕	6,68	5,30	37,7	3520	19	9,1	12*	28	400		1307	105	0,46
SGB 072C	⊕⊕	9,62	7,63	45,2	5600	28	10,6	12*	35	400		1362	205	0,90
SGB 082C	⊕⊕	11,94	9,47	67,7	5800	28	16,6	15*	35	400	230/400	1362	205	0,90
SGB 092C	⊕⊕	16,86	13,37	81,2	9060	37	19,8	15*	35	500	±10%V-3~	1417	360	0,86
SGB 102C	⊕⊕	19,01	15,07	108,0	9320	37	26,1	15*	42	500	50/60 Hz	1417	360	0,86
SGB 013C	⊕⊕⊕	2,73	2,16	14,2	2100	15	3,4	10	15	250		1301	32	0,15
SGB 023C	⊕⊕⊕	3,40	2,69	19,1	1920	15	4,5	10	22	250		1301	32	0,15
SGB 033C	⊕⊕⊕	5,21	4,12	24,3	3900	21	5,8	10	28	300	230±10%	1295	86	0,38
SGB 043C	⊕⊕⊕	6,00	4,76	32,5	3690	21	8,1	10*	28	300	V-1~	1295	86	0,38
SGB 053C	⊕⊕⊕	8,73	6,92	45,1	5310	24	11,1	12*	35	400	50/60 Hz	1307	105	0,46
SGB 063C	⊕⊕⊕	10,02	7,95	56,5	5280	24	13,1	12*	35	400		1307	105	0,46
SGB 073C	⊕⊕⊕	14,43	11,43	67,6	8400	34	16,2	15*	35	400		1362	205	0,90
SGB 083C	⊕⊕⊕	17,92	14,20	101,0	8700	34	24,5	22*	42	400		1362	205	0,90
SGB 093C	⊕⊕⊕	25,29	20,07	122,0	13600	45	29,6	22*	54	500	230/400	1417	360	0,86
SGB 103C	⊕⊕⊕	28,50	22,61	162,0	14000	45	38,5	22*	54	500	±10%V-3~	1417	360	0,86
SGB 103C	⊕⊕⊕	28,50	22,61	162,0	14000	45	38,5	22*	54	500	50/60 Hz	1417	360	0,86

* Multiple injection with direct expansion using Küba CAL® distributors. The cooler rating at 60 Hz is 10% higher on average due to the higher speed and higher air flow.

50



Q_v chart (EN328, R404A) SGB...C 

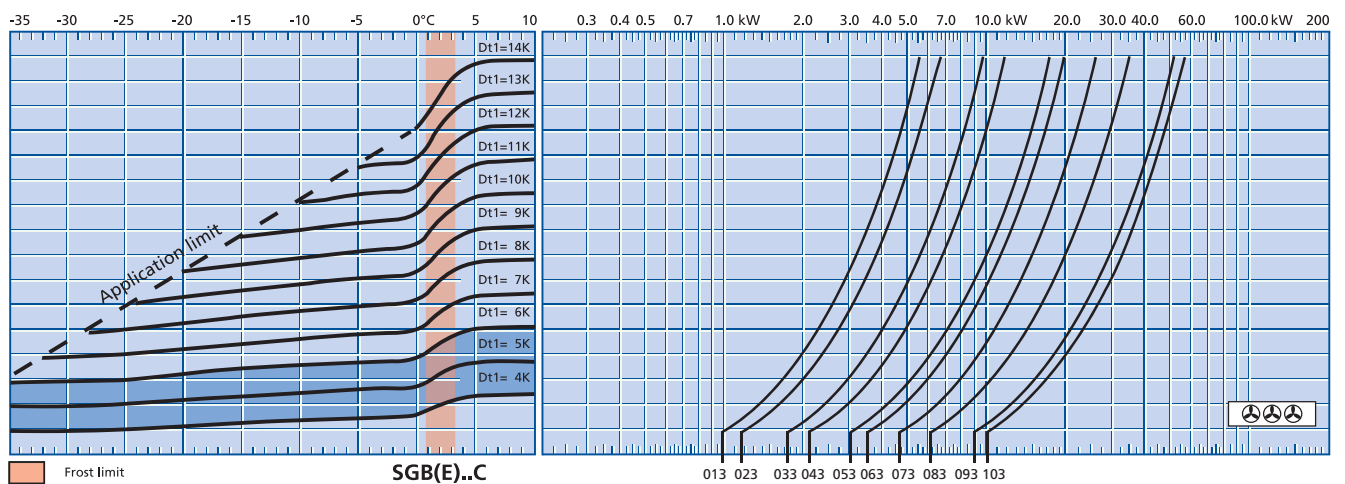
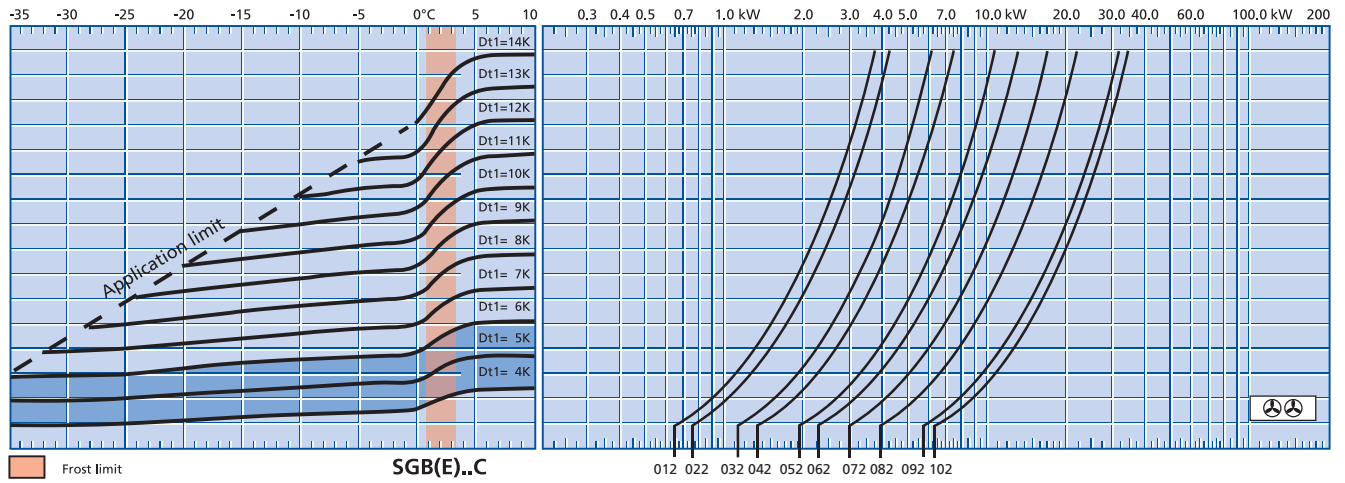
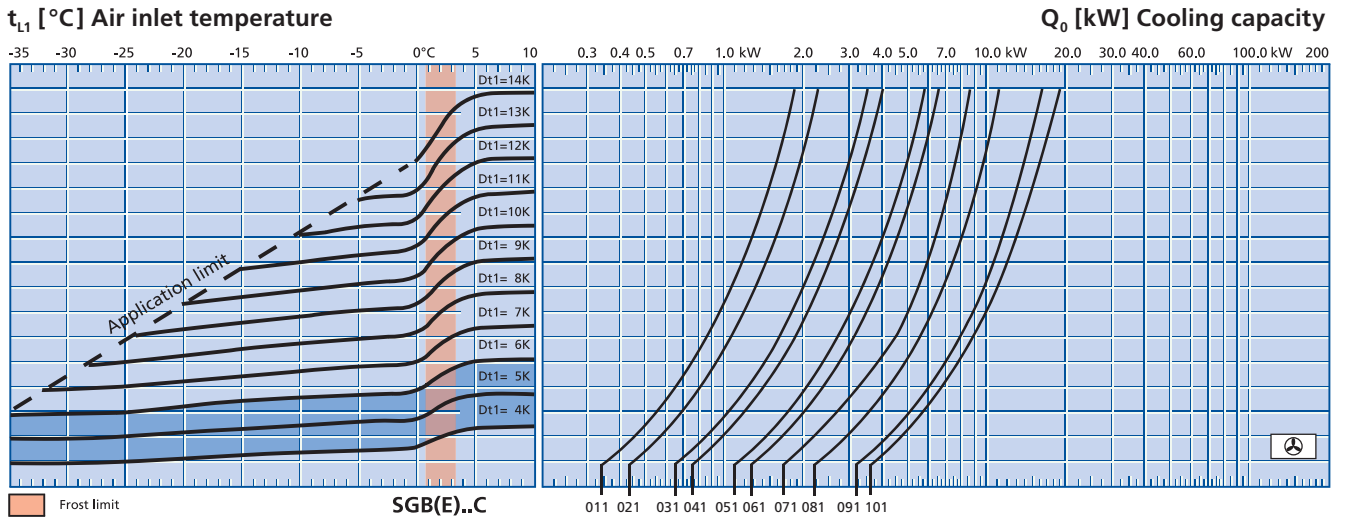

Q₀ = Cooling capacity
 t_{L1} = Air inlet temperature
 t₀ [°C] = Evaporating temperature (coil outlet)
 DT1 [K] = Temperature difference = t_{L1} - t₀ (°C)

DT1 = 4 K bis 6 K
 with electronic expansion valve

Example selection:
 For example and explanation, see the information section on p. 136.



Technical data (R404A)

SGL...C



Model		Rating Q ₀ at 50 Hz		Surface m ²	Air flow m ³ /h	Air throw m	Tube volume dm ³	Connections			Type of current	Fans (operating values at 50 Hz)		
		t ₁₁ ± 0 °C DT1 = 8K						Inlet Ø mm	Outlet Ø mm	Blade Ø mm		min ⁻¹	W	A
		kW	kW											
SGL 051C	⊕	2,20	1,74	9,5	1910	15	3,8	10	22	400	230±10% V-1~	1307	105	0,46
SGL 061C	⊕	2,60	2,06	11,8	1900	15	4,8	10	22	400	50/60 Hz	1307	105	0,46
SGL 071C	⊕	3,69	2,92	14,1	3020	21	5,7	10*	22	400	230/400 ±10% V-3~	1362	205	0,90
SGL 081C	⊕	4,70	3,73	21,1	3130	21	8,8	10*	28	400	50/60 Hz	1362	205	0,90
SGL 091C	⊕	6,58	5,21	25,2	4890	28	10,6	10*	28	500	230/400 ±10% V-3~	1417	360	0,86
SGL 101C	⊕	7,48	5,93	33,5	5020	28	13,6	12*	35	500	50/60 Hz	1417	360	0,86
SGL 102C	⊕⊕	1,45	1,15	5,9	1610	14	2,3	10	15	250		1301	32	0,15
SGL 103C	⊕⊕⊕	2,17	1,72	8,7	2410	17	3,4	10	15	250		1301	32	0,15
SGL 122C	⊕⊕	1,75	1,39	8,0	1470	14	3,1	10	18	250		1301	32	0,15
SGL 132C	⊕⊕	2,63	2,08	11,6	2210	17	4,5	10	22	250		1301	32	0,15
SGL 032C	⊕⊕	2,55	2,02	10,1	2990	19	3,9	10	18	300	230±10% V-1~	1295	86	0,38
SGL 042C	⊕⊕	3,09	2,45	13,5	2710	19	5,3	10	22	300	50/60 Hz	1295	86	0,38
SGL 052C	⊕⊕	4,40	3,49	18,5	3820	21	7,6	10*	28	400		1307	105	0,46
SGL 062C	⊕⊕	5,21	4,13	23,2	3800	21	9,1	12*	28	400		1307	105	0,46
SGL 072C	⊕⊕	7,38	5,84	27,8	6050	30	10,6	12*	35	400		1362	205	0,90
SGL 082C	⊕⊕	9,39	7,45	41,5	6260	30	16,2	15*	35	400	230/400 ±10% V-3~	1362	205	0,90
SGL 092C	⊕⊕	13,14	10,41	50,0	9780	40	19,8	15*	35	500	50/60 Hz	1417	360	0,86
SGL 102C	⊕⊕	14,95	11,85	66,3	10000	40	26,1	15*	42	500		1417	360	0,86
SGL 013C	⊕⊕⊕	3,82	3,03	15,0	4490	24	5,8	10	28	300	230±10% V-1~	1295	86	0,38
SGL 023C	⊕⊕⊕	4,63	3,67	20,0	4240	24	8,1	10*	28	300	50/60 Hz	1295	86	0,38
SGL 033C	⊕⊕⊕	6,61	5,23	27,7	5730	26	11,0	12*	35	400		1307	105	0,46
SGL 043C	⊕⊕⊕	7,81	6,19	34,6	5700	26	13,1	12*	35	400		1307	105	0,46
SGL 053C	⊕⊕⊕	11,05	8,75	41,3	9070	37	16,2	15*	35	400		1362	205	0,90
SGL 063C	⊕⊕⊕	14,10	11,17	62,1	9400	37	24,5	22*	42	400	230/400 ±10% V-3~	1362	205	0,90
SGL 073C	⊕⊕⊕	19,72	15,63	74,5	14700	49	29,6	22*	54	500	50/60 Hz	1417	360	0,86
SGL 083C	⊕⊕⊕	22,43	17,77	99,1	15100	49	38,5	22*	54	500		1417	360	0,86

* Multiple injection with direct expansion using Küba CAL® distributors. The cooler rating at 60 Hz is 10% higher on average due to the higher speed and higher air flow.

52



Q_v chart (EN328, R404A) SGL...C  **12 mm**

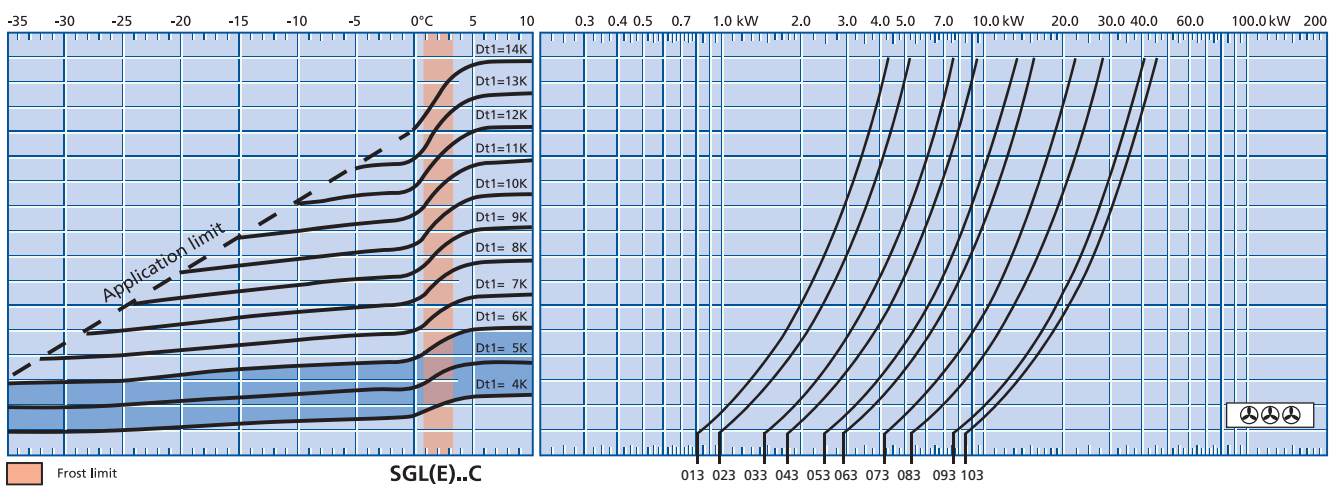
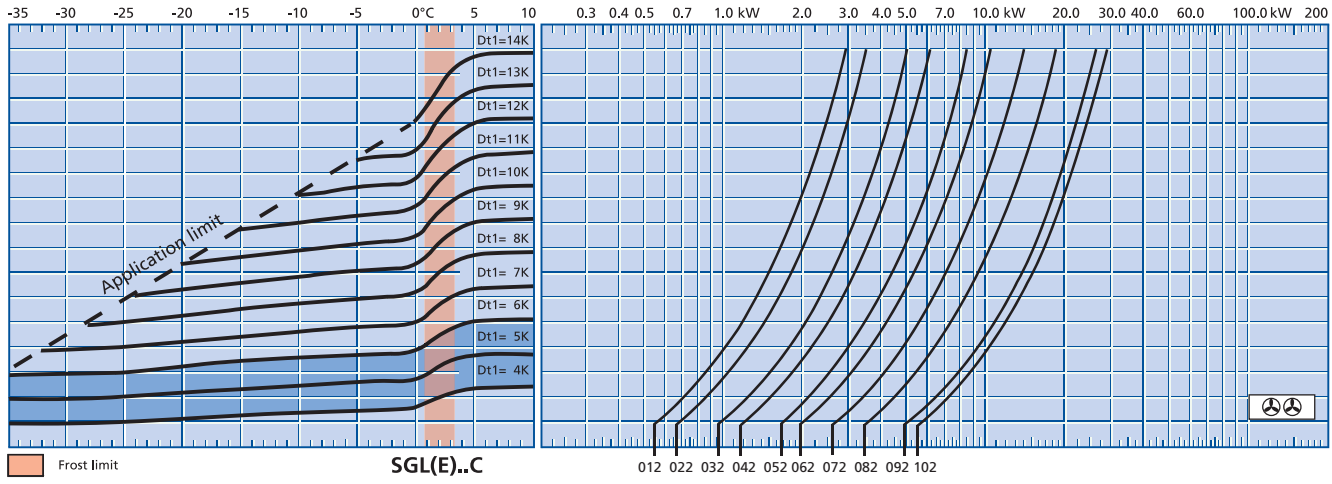
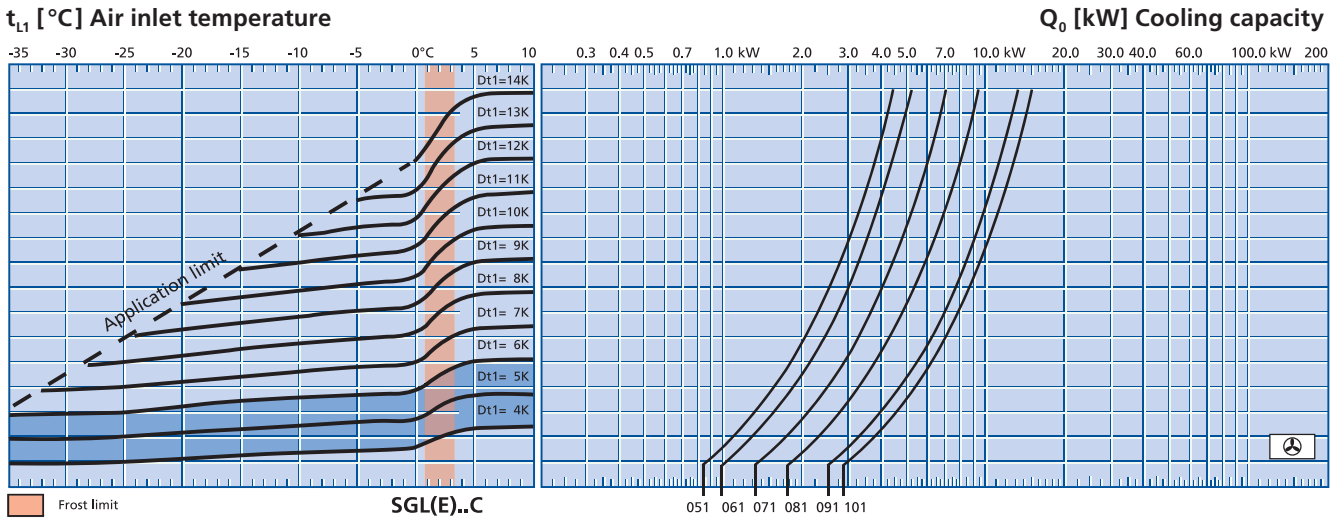

Q₀ = Cooling capacity
 t_{L1} = Air inlet temperature
 t₀ [°C] = Evaporating temperature (coil outlet)
 DT1 [K] = Temperature difference = t_{L1} - t₀ (°C)

DT1 = 4 K bis 6 K
 with electronic expansion valve

Example selection:
 For example and explanation, see the information section on p. 136.



Dimensional drawings

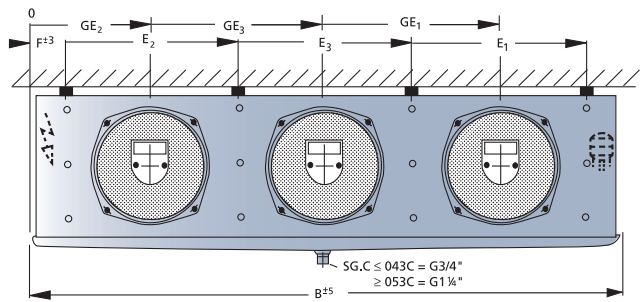
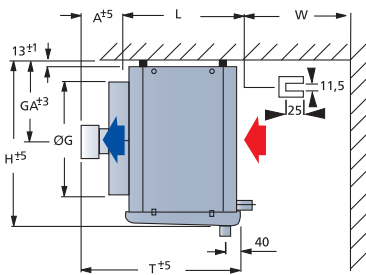
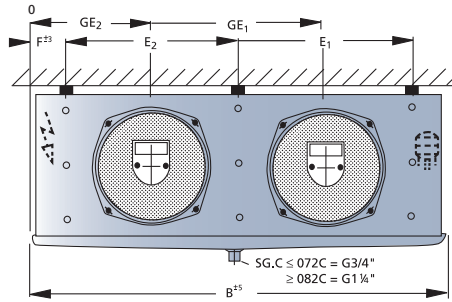
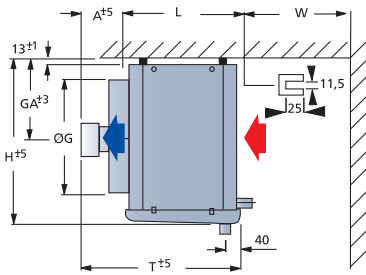
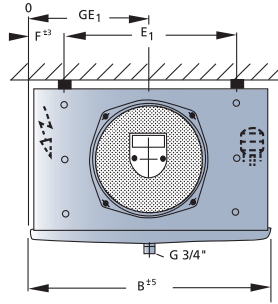
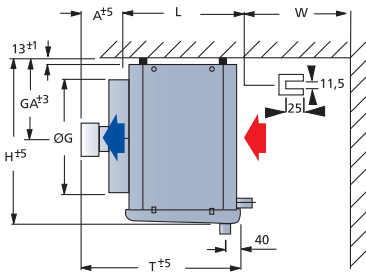

54



With double, insulated drip trays the following dimensions are changed:

- Width B:** +60mm
- Height H:** +30mm
- Depth T:** +30mm

Sound power level L_{WA} [dB(A)]



Größe	SGA/SGB/SGL		
	⊕	⊕ ⊕	⊕ ⊕ ⊕
01	59	62	64
02	59	62	64
03	66	69	71
04	66	69	71
05	70	73	75
06	70	73	75
07	75	78	80
08	75	78	80
09	78	81	83
10	78	81	83



Dimensional drawings, electric defrosting, weights

Size	Dimensions [mm]																Electrical Defrosting			Net weight		
	H	B	T	L	E ₁	E ₂	E ₃	F	A	W	W Hood	ØG	GA	GE ₁	GE ₂	GE ₃	Coil	Tray	Total	SGA	SGB	SGL
	mm	mm	mm	mm	mm	mm	mm	mm	mm	mm	mm	mm	mm	mm	mm	mm	mm	kW	kW	kW	kg	kg
011C	360	565	420	345	380	-	-	93	80	200	290	265	160	283	-	-	0,77	0,35	1,16	12	11	-
021C	360	565	420	345	380	-	-	93	80	200	290	265	160	283	-	-	0,77	0,35	1,16	13	12	-
031C	460	665	440	345	480	-	-	93	100	200	340	321	210	333	-	-	0,96	0,42	1,38	18	17	-
041C	460	665	440	345	480	-	-	93	100	200	340	321	210	333	-	-	0,96	0,42	1,38	20	19	-
051C	560	815	570	415	530	-	-	143	160	300	430	419	260	408	-	-	1,44	0,24	1,68	30	29	28
061C	560	815	570	415	530	-	-	143	160	300	430	419	260	408	-	-	1,61	0,24	1,85	33	32	30
071C	560	915	640	495	630	-	-	143	150	300	430	419	260	458	-	-	1,73	0,29	2,02	41	39	37
081C	560	1065	640	495	780	-	-	143	150	300	430	419	260	533	-	-	2,18	0,35	2,53	53	51	49
091C	660	1065	650	495	780	-	-	143	160	400	500	525	320	533	-	-	2,90	0,35	3,25	62	59	56
101C	660	1315	650	495	1030	-	-	143	160	400	500	525	320	658	-	-	3,68	0,44	4,12	71	68	65
012C	360	1015	420	345	730	365	-	143	80	200	290	265	160	690	325	-	1,38	0,69	2,07	23	21	19
022C	360	1015	420	345	730	365	-	143	80	200	290	265	160	690	325	-	1,38	0,69	2,07	24	22	20
032C	460	1215	440	345	930	465	-	143	100	200	340	321	210	840	375	-	1,72	0,77	2,49	35	33	31
042C	460	1215	440	345	930	465	-	143	100	200	340	321	210	840	375	-	1,72	0,77	2,49	39	37	35
052C	560	1375	570	415	1030	515	-	173	160	300	430	419	260	945	430	-	2,64	0,44	3,08	58	55	53
062C	560	1375	570	415	1030	515	-	173	160	300	430	419	260	945	430	-	2,64	0,44	3,08	64	61	58
072C	560	1575	640	495	1230	615	-	173	150	300	430	419	260	1095	480	-	3,11	0,52	3,63	80	76	72
082C	560	1875	640	495	1530	765	-	173	150	300	430	419	260	1320	555	-	3,90	0,65	4,55	104	100	96
092C	660	1875	650	495	1530	765	-	173	160	400	500	525	320	1320	555	-	6,50	0,65	7,15	120	114	108
102C	660	2375	650	495	2030	1015	-	173	160	400	500	525	320	1695	680	-	8,42	0,84	9,27	137	130	123
013C	360	1365	420	345	1080	365	715	143	80	200	290	265	160	1040	325	683	1,84	0,92	2,76	34	31	28
023C	360	1365	420	345	1080	365	715	143	80	200	290	265	160	1040	325	683	1,84	0,92	2,76	37	34	31
033C	460	1665	440	345	1380	465	915	143	100	200	340	321	210	1290	375	833	2,42	1,21	3,63	51	48	45
043C	460	1665	440	345	1380	465	915	143	100	200	340	321	210	1290	375	833	2,42	1,21	3,63	57	54	51
053C	560	1875	570	415	1530	515	1015	173	160	300	430	419	260	1445	430	938	3,90	0,65	4,55	86	81	76
063C	560	1875	570	415	1530	515	1015	173	160	300	430	419	260	1445	430	938	3,90	0,65	4,55	95	90	85
073C	560	2175	640	495	1830	615	1215	173	150	300	430	419	260	1695	480	1088	4,47	0,75	5,22	118	111	104
083C	560	2625	640	495	2280	765	1515	173	150	300	430	419	260	2070	555	1313	5,63	0,94	6,57	154	147	140
093C	660	2625	650	495	2280	765	1515	173	160	400	500	525	320	2070	555	1313	9,37	0,94	10,32	180	170	160
103C	660	3375	650	495	3030	1015	2015	173	160	400	500	525	320	2695	680	1688	12,09	1,82	13,92	240	228	216



The dimensions are only valid for standard model design!
Note the differences in dimension for versions and accessories.



Models

Motor versions

• **Version V1.33 – quiet design**

Particularly suited for sales areas, etc.

- Reduced air flow rate, VL
- Lower sound power level, Lw (A)
- Fans 230 ± 10% V-1~



For other alternative motor versions, see Küba Select or version overview, p. 126

Water / brine circulation

• **Version V2.05**

Large number of circuits (small pressure drop)

• **Version V2.06**

Small number of circuits (large pressure drop)

Casing versions

Double insulated drip tray

• **V3.09**



The double insulated drip tray has 25 mm of insulation.

The insulation prevents condensation water from building up on the bottom side of the tray and reduces the transfer of defrosting heat into the Cold Room.

This changes the following dimensions:

Width B: +60 mm

Hight H: +30 mm

Depth T: +30 mm

Hinged fans

• **V3.10**



To make the coolers easy to clean, the fans are mounted with stainless steel hinges.

Hinge-down drip tray

• **V3.11**



The hinge-down drip tray is easy to assemble and makes it easy to clean the devices from below.

Defrost versions

All Küba Air Coolers are available with electric defrosting. See nomenclature, p. 48

Hot gas defrost in the drip tray

- Hot gas connection on both sides
- V4.01 Copper design
- V4.02 Stainless steel design



Hot gas in the heat exchanger

- V6.05 Hot gas connection on the heat exchanger



Hot gas in the heat exchanger and in the drip tray, copper design
Copper with/without check valve

- Hot gas connection on both sides
- V6.07 with check valve
- V6.08 without check valve

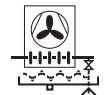

On request: additional defrosting circuit: warm brine; the circuit is integrated into the heat exchanger.

Corrosion protection

Stainless steel casing

• **V3.12**



For protection in aggressive cold storage air, e.g. in smokehouses and curing areas, all casing components are stainless steel. Industrial quality.

• **Version V6.01**



Heat exchanger:

Tubing: Cu

Fins: Al „goldlack“ coating

End plates: Al protective coating on both sides

Casing: Al-Stucco.

Top Panel: Sendzimir galvanised steel, protective coating on both sides



Models

- **Version V6.02**



Heat exchanger:

Tubing: Stainless steel
 Fins: „goldlack“ coating
 End plates: Stainless steel

Casing: Al-stucco.

Top Panel: Sendzimir galvanised steel,
 protective coating on both sides

Refrigerant distributor: Standard Venturi

Stainless steel CAL® distributor on request

- **Version V6.03**



Heat exchanger:

Tubing: Stainless steel
 Fins: Al
 End plates: Al

Casing: Al-Stucco.

Top Panel: Sendzimir galvanised steel,
 protective coating on one side

Refrigerant distributor: Standard Venturi

Stainless steel CAL® distributor on request

- **Version V6.04**



Heat exchanger:

Tubing: Cu
 Fins: Al „goldlack“ coating
 End plates: Al

Casing: Al-Stucco.

Top Panel: Sendzimir galvanised steel,
 protective coating on one side



Further information regarding
 corrosion protection can be found
 on pages 132 to 135



Accessories

Adapter for textile hose connection and Shut-Up®

With the adapter (aluminium, powder-coated RAL 9018) mounting a PVC or textile hose and the Küba Shut-Up® quick and easy.

**Straightener design: plastic
(not suitable for fan collar heaters)**

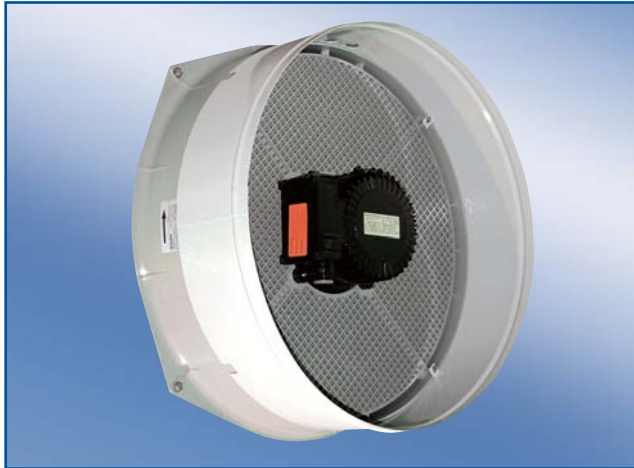

Selection table

For Air Coolers	Adapter		Note
	Quantity	ØG mm	
SG 011-021C	1	270	
SG 031-041C	1	325	
SG 051-061C	1	425	
SG 071-081C	1	425	
SG 091-101C	1	525	
SG 012-022C	2	270	
SG 032-042C	2	325	Not assembled upon delivery (cannot be used with electric defrosting SGHR)
SG 052-062C	2	425	
SG 072-082C	2	425	
SG 092-102C	2	525	
SG 013-023C	3	270	
SG 033-043C	3	325	
SG 053-063C	3	425	
SG 073-083C	3	425	
SG 093-103C	3	525	



For greater pressure drops we recommend using more powerful fans. When using textile or PVC hoses, take the Ø G (mm) in the selection table into consideration. For more information, contact our sales engineers, Tel.: ++49 (0)89 / 74473-0. For more detailed information, please see the information provided by the textile or PVC hose manufacturer.

Fan unit for assembling fan collar heaters

This fan unit (collar made of aluminium, powder-coated RAL 9018) is used to assemble a fan collar heater.

**Fan design:
suitable for use with fan collar heaters**



Applications

- Assembling fan collar heaters for deep-freezing starting at -18°C

If fan collar heaters are used for a deep-freeze application, a fan with an aluminium collar must be used instead of the standard fan unit. Please note this circumstance in planning.

Scope of delivery

Complete fan unit consisting of:

Collar:	Al Stucco, white powder-coated RAL 9018 Food quality Good protection against corrosion
Air Straightener:	Plastic
Motor and blade:	As for standard



Accessories

Recommended for frozen storage

- Shut-Up®
- Defrost hood
- Fan collar heaters
- Double insulated drip tray
- Insulate the top panel on site

Shut-Up®

The Küba Shut-Up® optimises the defrost process, particularly in deep-freeze applications.

Applications

- Frozen storage starting at -18°C
- Alternating defrosting of the Air Coolers in one room

Advantages (in connection with the defrosting hood)

With Shut-Up® and the defrost hood, a positive accumulation of heat occurs in the air cooler during the defrost process. The heat remains in the cooler, which means:

- Defrost times reduced by more than 50%
- Significant amounts of energy saved
- No frost build-up on the ceiling of the storage room or on the goods due to minimal vapour build-up
- Defrost temperature in cooler is $\leq 5^{\circ}\text{C}$

Calculation hint

Due to the additional external pressure, the air quantity and air cooler capacity change:

Model	Change in air quantity	Change in rating
SG commercial	-10%	-5%

Selection table

for model	Shut-Up®
SG... ☺	1 piece
SG... ☺ ☺	2 pieces
SG... ☺ ☺ ☺	3 pieces

Please plan to use an adapter.
Shut-Up® is not assembled upon delivery.



Cooling phase, fans switched on: Shut-Up® is inflated



Defrosting, fans switched off: Shut-Up® closes the air cooler



Accessories

Defrost hood

The defrosting hood optimises the defrost process, particularly in deep-freeze applications.

Applications

- Frozen storage starting at -18 °C
- Alternating defrosting of the Air Coolers in one room

Advantages (in connection with Shut-Up®)

With the defrost hood and Shut-Up® a positive accumulation of heat occurs in the air cooler during the defrost process. The heat remains in the cooler, which means:

- Defrost times reduced by more than 50%
- Significant amounts of energy saved
- No frost build-up on the ceiling of the storage room or on the goods due to minimal vapour build-up
- Defrost temperature in cooler is $\leq 5^{\circ}\text{C}$

Construction

- The defrosting hood consists of 6 mm of thick expanded polycarbonate
- To a large extent, the insulated plastic prevents temperatures from falling below the dew point and the related formation of ice.
- The material is temperature resistant from -100 °C to +140 °C
- Results of endurance tests with regard to contact with foodstuffs are available.
- The defrosting hoods are delivered as a kit for every fan module and can be assembled on site according to the enclosed assembly instructions
- Please note the minimum wall clearance „W_{min}“

Module dimensions and weight:

Model	H mm	B mm	T mm	Weight kg	W _{min.} mm
SG 11-23	600	352	270	1,8	290
SG 31-14	700	452	340	2,5	340
SG 51-63	800	502	410	3,0	430
SG 71-73	800	602	410	3,4	430
SG 81-83	800	752	410	4,1	430
SG 91-93	900	752	480	4,5	500
SG 101-103	900	1002	480	5,6	500

Calculation hint

Due to the additional external pressure, the air quantity and air cooler capacity change:

Model	Change in air quantity	Change in rating
SG commercial	-10%	-5%

For deep-freeze applications, Küba engineers recommend an insulated drip tray.

Defrosting process with Shut-Up® and defrost hood

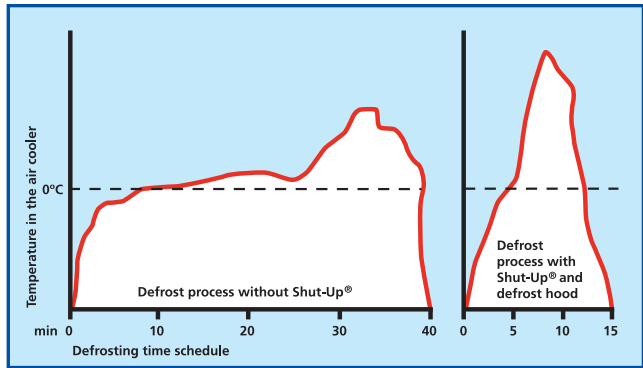

Defrost time reduced by more than half

Defrost hood at air inlet

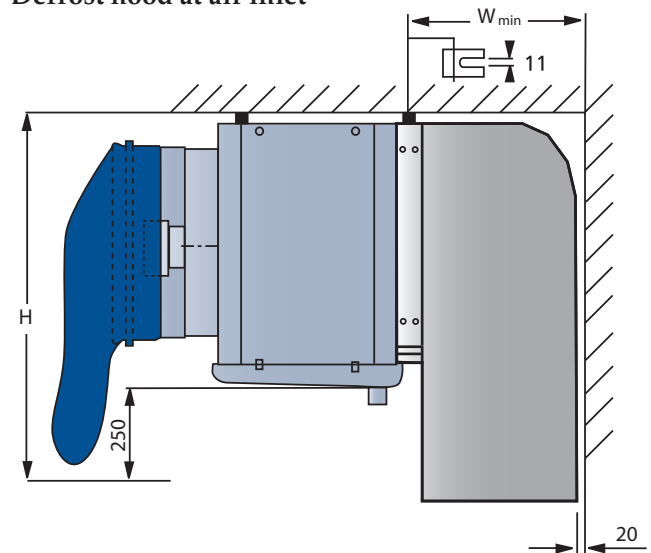

60



Accessories

Fan collar heater VRB

Benefits:

Prevents the fan blade at the collar from freezing up (in cases of extreme humidity in the freezer and frozen storage area)

Scope of delivery:

Electric tubular heater with stainless steel sleeve Ø 8,5 mm

Connection ends: 1,5 x 2000 mm

Tension spring: stainless steel



Technical data

Model	for blade mm	Nominal rating at 230V kW	Ø mm D _i	Weight kg
VRB 25	250	0,31	270	0,35
VRB 30	300	0,39	325	0,40
VRB 40	400	0,48	425	0,50
VRB 50	500	0,27	525	0,55

Selection table

For Air Coolers	VRB Quantity	Model Designation	Connection power / cooler kW
SG 011, 021C	1	VRB 25	0,31
SG 031, 041C	1	VRB 30	0,39
SG 051, 061C	1	VRB 40	0,48
SG 071, 081C	1	VRB 40	0,48
SG 091, 101C	1	VRB 50	0,27
SG 012, 022C	2	VRB 25	0,62
SG 032, 042C	2	VRB 30	0,78
SG 052, 062C	2	VRB 40	0,96
SG 072, 082C	2	VRB 40	0,96
SG 092, 102C	2	VRB 50	0,54
SG 013, 023C	3	VRB 25	0,93
SG 033, 043C	3	VRB 30	1,17
SG 053, 063C	3	VRB 40	1,44
SG 073, 083C	3	VRB 40	1,44
SG 093, 103C	3	VRB 50	0,81

Fan collar heater cover

Benefits:

- Contact protection
- Reduces heat radiation from the fan collar heaters into the Cold Room
- Improves heat conductivity at the collar
- Increases the efficiency of the fan collar heaters
- Protects against slipping



Only available in connection with a metal air duct; fan unit for assembling a fan collar heater VRB, page 58!





Accessories

Mounting material, wall bracket / floor bracket

Wall bracket (WK)

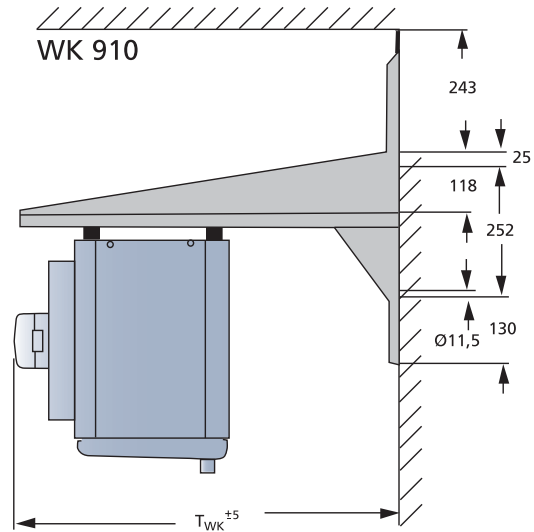
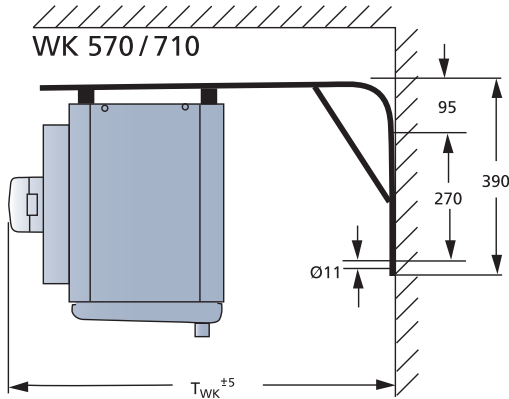

Design: Galvanised steel

SG.	011-013C	021-023C	031-033C	041-043C	051-053C	061-063C	071-073C	081-083C	091-093C	101-103C
WK	570	570	570	570	710	710	910	910	910	910
T _{wk} [mm]	615	615	635	635	835	835	1000	1000	1010	1010

Floor brackets (SK)

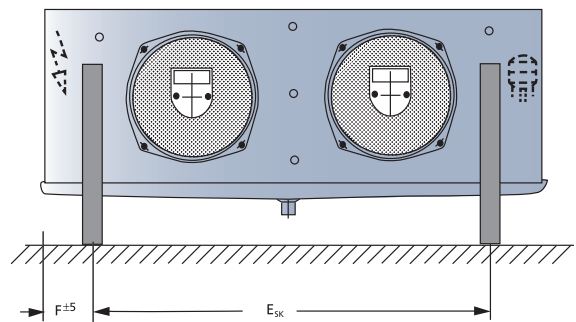
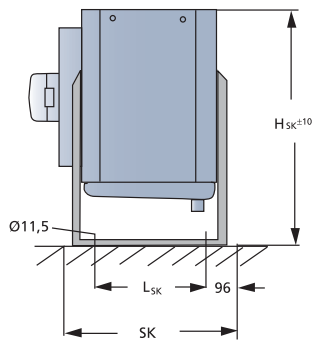

Design: SK 460, 510 = Al

SG.		051-053C	061-063C	071-073C	081-083C	091-093C	101-103C
SK		460	460	460	460	510	510
Dimensions [mm]	SK	460	460	460	460	510	510
	H _{SK}	685	685	785	785	785	785
	L _{SK}	478	478	558	558	558	558
	E _{SK}	} ≙ E1 und F } ≙ According to dimension table p.55					
	F						

No floor mounting brackets are available for SG. 011 - 043C.



Accessories

Finned tube heaters SGHR

For Air Coolers with draw-through fans, on site assembly.
Suitable for air conditioning or heating in winter.



Only for use with running air cooler fans so that the ceiling of the cold storage areas does not overheat. Please observe the respective safety guidelines.

- Scope of delivery:
- Electric finned tube heater in stainless steel
 - Connection ends: 1,5 x 2000 mm
 - Assembly kit
 - Connection box IP 54

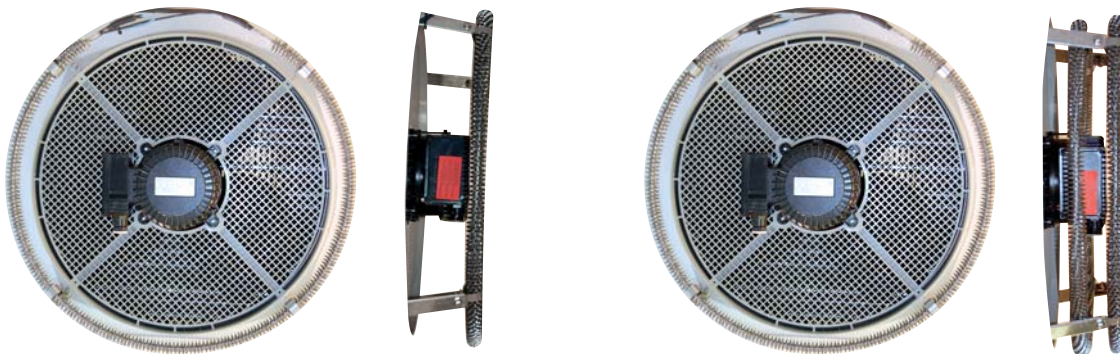

Normal construction version

Additional heater for greater heating capacity

Model	for blade Ø mm	Nominal rating at 230V kW	Weight kg	Model	Nominal rating at 230V kW	Weight kg
SGHR 25	250	1,36	0,65	SGHR 25 Z	1,36	0,65
SGHR 30	300	1,75	0,75	SGHR 30 Z	1,75	0,75
SGHR 40	400	2,47	0,94	SGHR 40 Z	2,47	0,94
SGHR 50	500	3,19	1,13	SGHR 50 Z	3,19	1,13

For Air Coolers

Normal heating capacity

Greater heating capacity

	kW	Number to order	kW	Number to order
SG 011, 021C	1,36	1 SGHR 25	2,72	1 SGHR 25 + 1 SGHR 25 Z
SG 031, 041C	1,75	1 SGHR 30	3,50	1 SGHR 30 + 1 SGHR 30 Z
SG 051, 061C	2,47	1 SGHR 40	4,94	1 SGHR 40 + 1 SGHR 40 Z
SG 071, 081C	2,47	1 SGHR 40	4,94	1 SGHR 40 + 1 SGHR 40 Z
SG 091, 101C	3,19	1 SGHR 50	6,28	1 SGHR 50 + 1 SGHR 50 Z
SG 012, 022C	2,72	2 SGHR 25	5,44	2 SGHR 25 + 2 SGHR 25 Z
SG 032, 042C	3,50	2 SGHR 30	7,00	2 SGHR 30 + 2 SGHR 30 Z
SG 052, 062C	4,94	2 SGHR 40	9,88	2 SGHR 40 + 2 SGHR 40 Z
SG 072, 082C	4,94	2 SGHR 40	9,88	2 SGHR 40 + 2 SGHR 40 Z
SG 092, 102C	6,38	2 SGHR 50	12,76	2 SGHR 50 + 2 SGHR 50 Z
SG 013, 023C	4,08	3 SGHR 25	8,16	3 SGHR 25 + 3 SGHR 25 Z
SG 033, 043C	5,25	3 SGHR 30	10,50	3 SGHR 30 + 3 SGHR 30 Z
SG 053, 063C	7,41	3 SGHR 40	14,82	3 SGHR 40 + 3 SGHR 40 Z
SG 073, 083C	7,41	3 SGHR 40	14,82	3 SGHR 40 + 3 SGHR 40 Z
SG 093, 103C	9,57	3 SGHR 50	19,14	3 SGHR 50 + 3 SGHR 50 Z



Accessories

Air hoses (on site procurement, not available from Küba)

Ventilation can be optimised with textile / PVC air hoses.

Applications

- Applications in work and production areas
- Cooled goods that are sensitive to drafts (e.g. flowers, ripening cheeses)

Advantages

The air hoses make uniform air distribution possible at very low air speeds.

- Working in a draft-free environment yields low illness rates
- Maximum protection for sensitive cooled goods
- No condensation water: temperatures do not fall below the dew point because air can penetrate the woven material

Calculation hint

Please order the corresponding adapter (see page 58). Please take the respective pressure drop for the cooler rating into consideration.

