

SMARTPRESSUREGATE FANCONTROL

Druckregleinheit für Kälteanlagen
mit elektronischer Drucküberwachung und Digitalanzeige

Pressure regulator for refrigeration systems
with electronic pressure monitoring and digital display



Inhalt

	Seite
1. Bestimmungsgemäßer Gebrauch	2
2. Sicherheitshinweise	3
3. Spezifikationen	4
4. Druckmessbereiche.	4
5. Übersicht	5
6. Bezeichnungen	6
7. Anschlussdiagramm	7
8. Status-LEDs	7
9. Bedienung	8
10. Parameter.	9
11. Schaltverhalten HPC10
12. Schaltverhalten LPS10
13. Schaltverhalten HPS11
14. Lüftersteuerung.11
15. RS-485 (Modbus RTU).12
16. Entsorgung12
17. Wandbefestigung12

1. Bestimmungsgemäßer Gebrauch

Mit dem SMARTPRESSUREGATE SPG501 FANCONTROL können die Hoch- und Niederdrücke bei Kälteanlagen überwacht und mit Hilfe von Schaltausgängen geregelt und als Alarm ausgegeben werden. Über anlaoge Ausgänge können beispielsweise Lüfter geregelt werden.

Über die RS485-Schnittstelle kann das SPG501 mittels Modbus-RTU ausgelesen und parametrieret werden.

Einsetzbar für die Kältemittel R22, R134a, R404a, R407c, R407f, R410a, R448, R449, R507. Jede andere oder darüber hinausgehende Verwendung gilt nicht als bestimmungsgemäß.

2. Sicherheitshinweise



Bitte lesen Sie diese Betriebsanleitung sorgfältig durch.

Um ein sicheres und zuverlässiges Arbeiten zu gewährleisten das Gerät ausschließlich für die beschriebene Anwendung einsetzen.



Das Gerät darf nur von Kältetechnikern zertifizierter Betriebe mit elektrotechnischer Ausbildung Bereich Niederspannung installiert und in Betrieb genommen werden. Das Gerät darf nur von zertifizierten Kältetechnikern zertifizierter Betriebe bedient werden.



GEFAHR

Elektrischer Schlag kann zu Verbrennungen und lebensgefährlichen Verletzungen führen.

Das Gerät darf nicht geöffnet werden.

Bei Defekt an den Hersteller zurücksenden.



GEFAHR

Elektrischer Schlag kann zu Verbrennungen und lebensgefährlichen Verletzungen führen.

Vor Beginn von Installations- und Wartungsarbeiten Netzspannung abschalten.



VORSICHT

Bei Verwendung mit Kältemitteln, die nicht im Kapitel „Spezifikationen“ genannt sind, können aufgrund von höheren Drücken oder Undichtigkeiten Verletzungen folgen.



GEFAHR

Bei Verwendung mit brennbaren Kältemitteln können Brände entstehen.

Daher ist es Verboten das Gerät mit brennbaren Kältemitteln zu betreiben.



WARNUNG

Dieses Gerät ist keine sicherheitstechnische Einrichtung. Es darf nur im gewerblichen Bereich eingesetzt werden. Die Anlage muss unbedingt mit einem zugelassenen Sicherheitsventil ausgestattet sein. Bei Missachtung besteht die Gefahr von Verletzungen und Umweltschäden aufgrund von Kältemittelaustritt bei Überschreitung der Systemgrenzen.



WARNUNG

Unter Druck stehende Kältemittel können bei Austritt Augenverletzungen verursachen. Bei Installations- und Wartungsarbeiten Schutzbrille tragen.

3. Spezifikationen

- Versorgungsspannung: 100...240 VAC @ 47...63 Hz, 140...340 VDC
- Stromaufnahme: 200 mA max.
- Display: 3-stellige LED-Anzeige für LP (Niederdruck)
3-stellige LED-Anzeige für HP (Hochdruck)
- Schaltstrom Relais: 5A @ 250 VAC, nicht abgesichert.
Die angegebenen Schaltströme dürfen nicht überschritten werden und eine Absicherung muss zusätzlich extern dimensioniert werden!
- Kabelspezifikation: 1,4 A @ 20° C
- Analogausgang LP: 4...20 mA / 0...10 VDC @ -1...+19 bar
- Analogausgang HP: 4...20 mA / 0...10 VDC @ 0...50 bar ODER FANCONTROL (siehe Kap. 14)
- Arbeitstemperatur: -25°...+55° C RH 60 %
- Schutzklasse: IP 65 nach DIN EN 60529 / IEC 60529
- Druckanschlüsse: 7/16" - 20 UNF
- Kältemittel: R22, R134a, R404a, R407c, R407f, R410a, R448, R449, R507
- Lagerbedingungen: Das Gerät in sauberer und trockener Umgebung lagern.
Das Gerät für Unbefugte unzugänglich aufbewahren.



4. Druckmessbereiche

	Low Pressure (LP) relativ	High Pressure (HP) relativ
Druckbereich	-1...+19 bar / -14...+275 psi	0...50 bar / 0...725 psi
Genauigkeit	±0,5 % vom Endwert	
	±0,1 bar / ±1,5 psi	±0,25 bar / ±3,6 psi
Überlastwarnung	1 % Überlast („OFL“ blinkt & akkustische Warnung)	
	19,2 bar / 278 psi	50,5 bar / 732 psi
Überlast	3 % Überlast („OFL“-Anzeige & akkustische Warnung)	
	19,6 bar / 284 psi	51,5 bar / 746 psi
Physikalische Überlast	40 bar / 580 psi	100 bar / 1450 psi
Berstdruck	60 bar / 870 psi	140 bar / 2030 psi

5. Übersicht

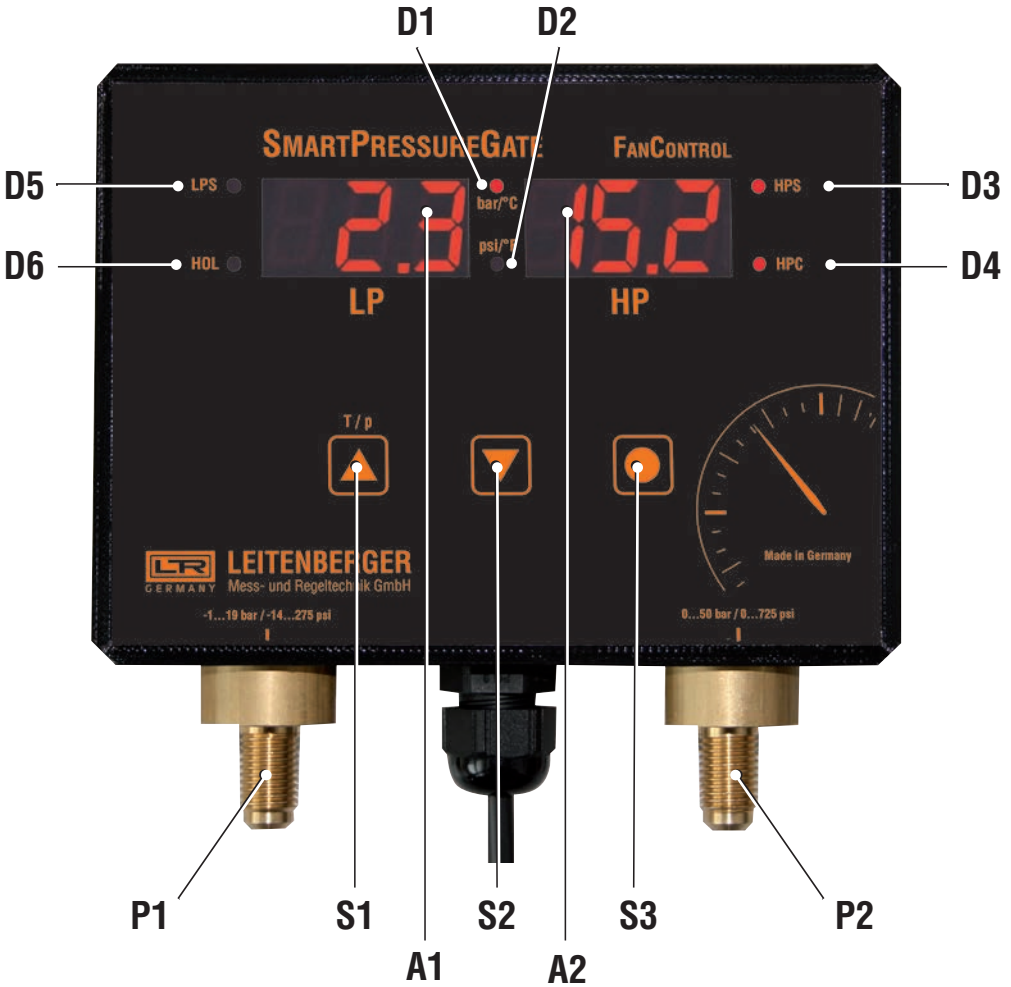

S1	Taste 1	D3	HPS LED
S2	Taste 2	D4	HPC LED
S3	Taste 3	D5	LPS LED
A1	LP Anzeige (Niederdruck)	D6	HOL LED
A2	HP Anzeige (Hochdruck)	P1	LP Sensor Anschluss
D1	bar/°C LED	P2	HP Sensor Anschluss
D2	psi/°F LED		

6. Bezeichnungen

HP (High Pressure):	Hochdruck nach dem Verdichter.
LP (Low Pressure):	Niederdruck vor dem Verdichter (Saugseite).
HPS (High Pressure Switch):	Einstellbarer HP-Wert um den Verdichter abzuschalten und ein Alarmsignal auszugeben.
Hdt (High Pressure Delay Timer):	Einstellbare Verzögerungszeit des HPS um ein instabiles Systemverhalten zu vermeiden.
HPd (HP Switch Differential Pressure):	Einstellbarer Differenzdruck bezogen auf den HP-Wert zum Wiedereinschalten des Verdichters.
HPC (High Pressure Control):	Einstellbarer HP-Wert um einen Ventilator am Kondensator zu steuern.
HIF (HP Differential Pressure):	Einstellbarer Differenzdruck bezogen auf HPC um den Ventilator am Kondensator abzuschalten.
LPS (Low Pressure Switch):	Zur Steuerung des Drucks an der Verdichter-Saugseite in Verbindung mit automatischer Rückstellung.
LIF (LP Differential Pressure):	Einstellbarer Differenzdruck in Verbindung mit Kondensator und Lüftermotorsteuerung.
Ldt (LP Delay Timer):	Einstellbare Verzögerungszeit beim Deaktivieren des LPS um ein instabiles Systemverhalten zu vermeiden.
FAN (Ventilatorsteuerung):	Ventilatorsteuerung über anlaogen Ausgang ein- oder ausschalten.
FHP (Fan High Pressure):	HP-Druck bei dem der maximale analoge Wert ausgegeben wird (aktiv bei „FAN ON“)
FLP (Fan Low Pressure):	HP-Druck bei dem der minimale analoge Wert ausgegeben wird (aktiv bei „FAN ON“)
FLL (Fan Low Level):	Minimaler anlaoger Wert der Spanne am Ausgang in %
H-A (Manual Mode & Automatic Mode):	Rückstellung des HPS bei $HP = HPS - HPd$. A: HPS wird automatisch wieder rückgestellt. H: HPS wird erst durch Quittierung an Taste 3 rückgestellt.
GAS:	Zum Einstellen des verwendeten Kältemittels.
Unt:	Zum Einstellen der angezeigten Druckeinheit.
C-F:	Zum Einstellen der angezeigten Temperatureinheit.
ADD:	Einstellen der Geräteadresse am RS485 Kommunikationsanschluss zur Verwendung am Modbus RTU.
RES:	Rücksetzen aller einstellbaren Parameter auf die Standardwerte.

7. Anschlussdiagramm

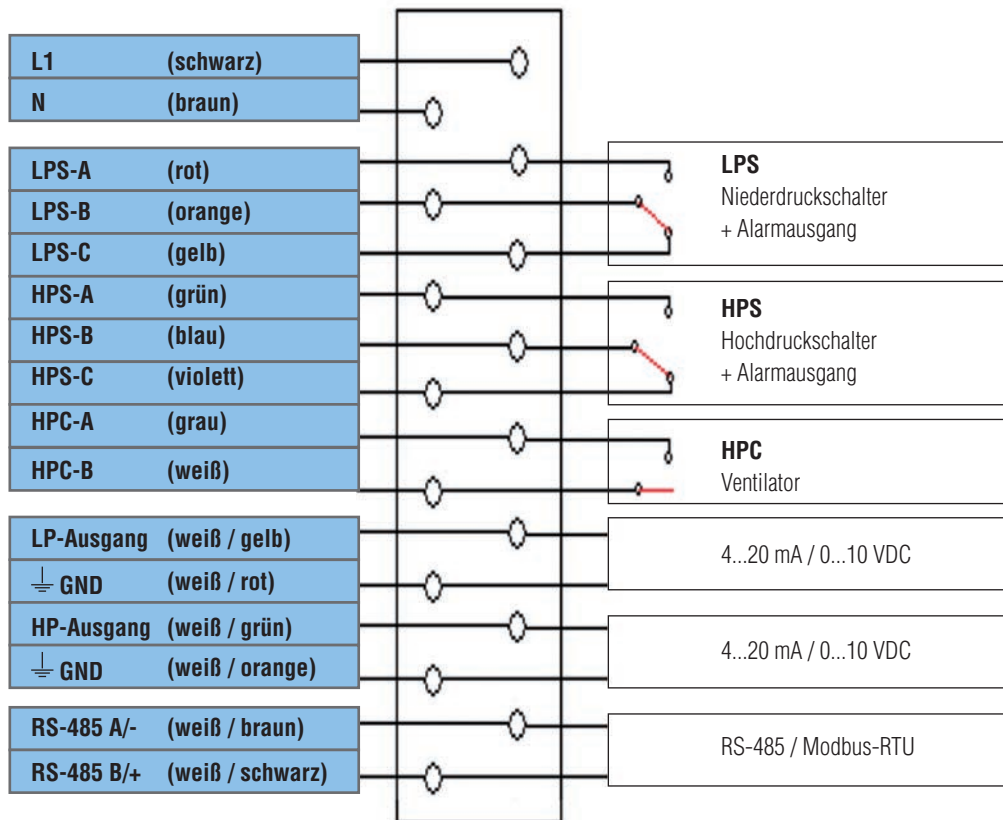

8. Status-LEDs

HPS:	Schaltzustand High Pressure Switch.
LPS:	Schaltzustand Low Pressure Switch.
HPC:	Schaltzustand High Pressure Control.
HOL:	aus → Automatik Mode aktiv an → Manual Mode aktiv blinkt → Einstellmodus aktiv
bar/°C:	
- Modus Druckanzeige:	an → Druckanzeige in bar
- Modus Temperaturanzeige:	an → Temperaturanzeige in °C
psi/°F:	
- Modus Druckanzeige:	an → Druckanzeige in psi
- Modus Temperaturanzeige:	an → Temperaturanzeige in °F

9. Bedienung



Modus Druckanzeige:

In diesem Modus werden die Drücke LP und HP in der eingestellten Einheit angezeigt.











































Modus Temperaturanzeige:

Mit der Taste  kann zwischen dem Modus Druckanzeige und dem Modus Temperaturanzeige gewechselt werden. Nach 20 Sekunden wird automatisch in den Modus Temperaturanzeige gewechselt.

Einstellmodus:

Durch langes Drücken der Taste  wird in den Einstellmodus gewechselt. Mit den Tasten  und  können die Parameter im Menü geändert werden. Durch kurzes Drücken in einzelnen Schritten und durch Drücken und Halten in erhöhter Geschwindigkeit.

Durch kurzes Drücken der Taste  kann im Menü navigiert werden:

PAS  ↓	→  oder  in 1-Schritten →  → zur nächsten Stelle Halten der Taste um das Passwort zu bestätigen oder zu überspringen Passwort wird überprüft, bei Übereinstimmung lassen sich nachfolgende Parameter ändern
HPS  ↓	→  oder  0,0...50,0 bar in 0,1er-Schritten / 0...725 psi in Einzelschritten
Hdt  ↓	→  oder  0...200 s in Einzelschritten
HPd  ↓	→  oder  0,0...50,0 bar in 0,1er-Schritten / 0...725 psi in Einzelschritten
HPC  ↓	→  oder  0,0...50,0 bar in 0,1er-Schritten / 0...725 psi in Einzelschritten
HIF  ↓	→  oder  0,0...50,0 bar in 0,1er-Schritten / 0...725 psi in Einzelschritten
FAN  ↓	→  oder  ON/OFF
FHP  ↓	→  oder  0,0...50,0 bar in 0,1er-Schritten / 0...725 psi in Einzelschritten
FLP  ↓	→  oder  0,0...50,0 bar in 0,1er-Schritten / 0...725 psi in Einzelschritten
FLL  ↓	→  oder  0...100 % in Einzelschritten
LPS  ↓	→  oder  -1,0...19,0 bar in 0,1er-Schritten / -14...+275 psi in Einzelschritten
LIF  ↓	→  oder  0,0...20,0 bar in 0,1er-Schritten / 0...290 psi in Einzelschritten
Ldt  ↓	→  oder  0...200 s in Einzelschritten
H-A  ↓	→  oder 

- GAS** ↓ → ▲ oder ▼
- UNT** ↓ → ▲ oder ▼
- C-F** ↓ → ▲ oder ▼
- ADD** ↓ → ▲ oder ▼ 0...255 in Einzelschritten
- RES** ↓ → ▲ oder ▼ halten → Rücksetzen aller einstellbaren Parameter auf Standardwerte
- END** ↓ → ▲ oder ▼ → Ende Einstellmodus, Wechsel zur Druckanzeige
Einstellmodus beginnt von vorne bei HPS

Der Einstellmodus wird automatisch beendet und zur Druckanzeige gewechselt, wenn 20 Sekunden lang keine Taste gedrückt wird. Durch Drücken und Halten der Taste  wird der Einstellmodus beendet und es wird zur Druckanzeige gewechselt.

10. Parameter

Label	Name	Grenzwerte	Standardwerte
HPS	High Pressure Switch	0,0...50 bar / 0...725 psi	30,0 bar / 435 psi
Hdt	Delay Timer für HPS Wert	0...200 s	0 s
HPd	Differential Pressure Wert für HPS Wert	0,0...50 bar / 0...725 psi	3,0 bar / 43 psi
HPC	Ventilator Pressure Control	0,0...50,0 bar / 0...725 psi	20,0 bar / 290 psi
HIF	Differential Pressure value für HPC Data	0,0...50,0 bar / 0...725 psi	5,0 bar / 73 psi
FAN	Ventilatorsteuerung	ON/OFF	OFF
FHP	Fan High Pressure (HP)	0,0...50,0 bar / 0...725 psi	20,0 bar / 290 psi
FLP	Fan Low Pressure (HP)	0,0...50,0 bar / 0...725 psi	5,0 bar / 73 psi
FLL	Fan Low Level	0...100 %	15 %
LPS	Low Pressure Switch	-1...19 bar / -14...+275 psi	7,0 bar / 102 psi
LIF	Differential Pressure Wert für LPS Data	0,0...20,0 bar / 0...290 psi	2,0 bar / 29 psi
Ldt	Delay Timer für LPS Wert	0...200 s	0 s
H-A	Auswahl Automatik- oder Manual-Modus	A: automatisch / H: manuell	A
GAS	Auswahl Kältemittel	R22, R134a, R404a, R407c, R407f, R410a, R448, R449, R507	R22
Unt	Auswahl Druckeinheit	bar, psi	bar
C-F	Auswahl Temperatureinheit	°C, °F	°C
Add	RS-485 Adresse für die Kommunikation	0...255	2
RES	Rücksetzen aller Parameter auf Standardwerte	---	---
End	Pfeiltaste zum Beenden drücken	---	---

11. Schaltverhalten HPC

HPC mit den folgenden eingestellten Parametern:

HPC: 20 bar

HIF: 5 bar

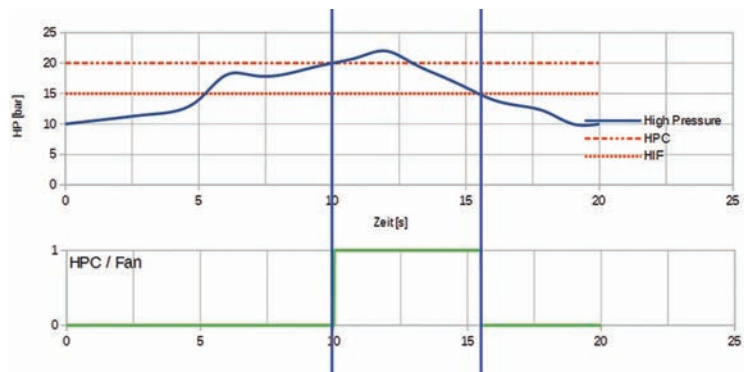

12. Schaltverhalten LPS

LPS mit den folgenden eingestellten Parametern:

LPS: 10 bar

Ldt: 3 Sekunden

LIF: 2 bar

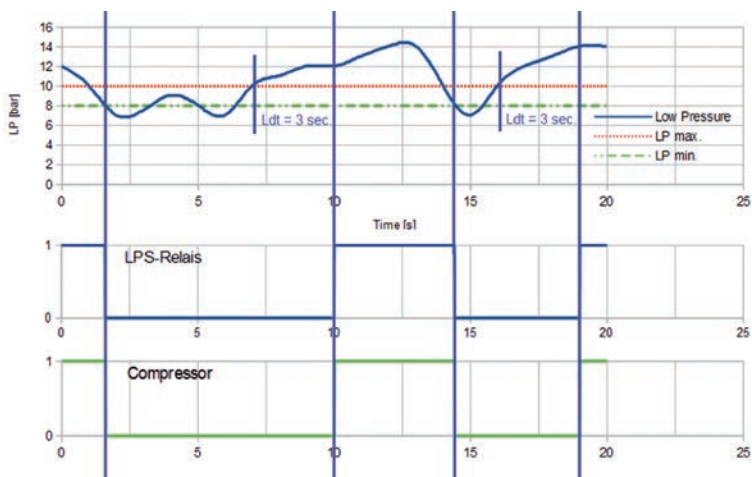

13. Schaltverhalten HPS

HPS mit den folgenden eingestellten Parametern:

- HPS: 30 bar
- Hdt: 3 Sekunden
- HPd: 3 bar

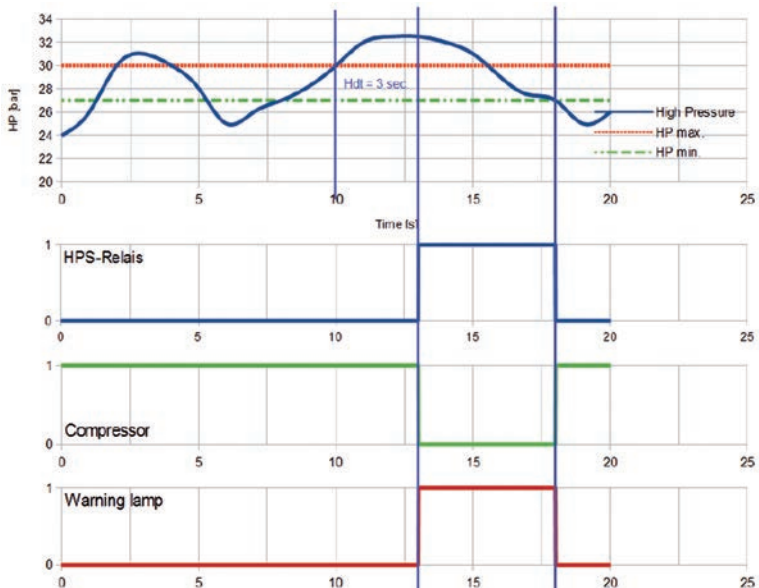

14. Lüftersteuerung

Analogausgang FANCONTROL mit folgenden eingestellten Parametern:

- FHP: 18 bar
- FLP: 6 bar
- FLL: 20 %

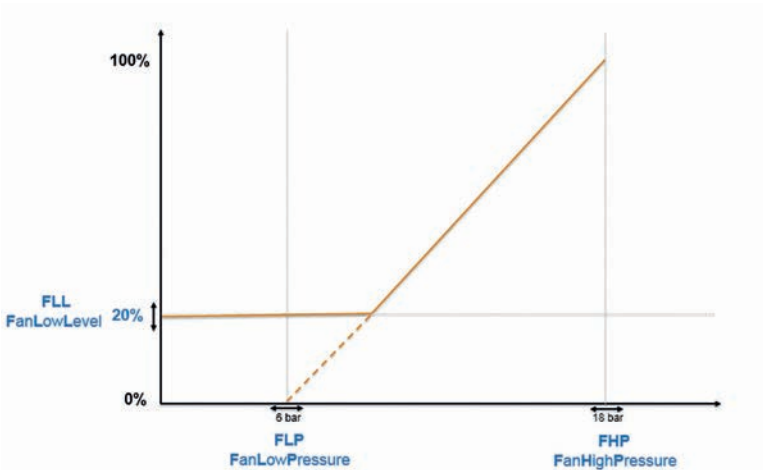

15. RS-485 (Modbus RTU)

Kommunikation:	RS485, Start-Stop synchronisierte serielle Schnittstelle
Baudrate:	9600 bit/s
Datenlänge:	8 bit Datenlänge
Stoppsbit:	1 Stoppsbit
Parität:	Keine Parität

Für detaillierte Spezifikationen zum Übertragungsprotokoll wenden Sie sich bitte an den Hersteller.
Kontaktinformationen siehe letzte Seite.

16. Entsorgung

Altgeräte dürfen nicht im Hausmüll entsorgt werden.
Altgerät zur Entsorgung bei dem Händler zurückgeben, bei dem es erworben wurde.
Das Gerät muss gemäß den gesetzlichen Bestimmungen entsorgt werden.



17. Wandbefestigung

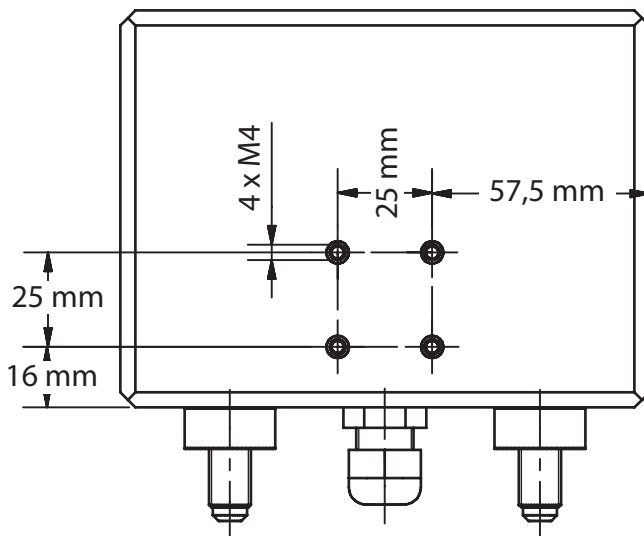

Content

	Page
1. Intended use	13
2. Safety precautions	14
3. Specifications.	15
4. Pressure Ranges	15
5. Overview	16
6. Notation	17
7. Connection diagram	18
8. Status LEDs.	18
9. Operating.	19
10. Parameters	20
11. Switching characteristics HPC	21
12. Switching characteristics LPS	21
13. Switching characteristics HPS	22
14. Fan control	22
15. RS-485 (Modbus RTU).	23
16. Disposal	23
17. Wall mounting	23

1. Intended use

With the SMARTPRESSUREGATE SPG501 FANCONTROL, the high and low pressures in refrigeration systems can be monitored and, with the aid of switching outputs, be regulated and output as alarms. The analog outputs can for example be used to regulate the fan.

Via the RS485 interface, the SPG501 can be read out and configured by means of Modbus RTU.

Can be used for refrigerants R22, R134a, R404a, R407c, R407f, R410a, R448, R449, R507. Any other use is considered a non-intended use.

2. Safety precautions



Please read these operating instructions carefully.

To ensure safe and reliable work, only use the device for the described application.



The device may only be installed and commissioned by refrigeration technicians from certified companies with electrotechnical training in the field of low voltage. The device may only be operated by certified refrigeration technicians from certified companies.



DANGER

Electrical shock can result in burns and life-threatening injuries. The device must not be opened. In the event of a defect, return the device to the manufacturer.



DANGER

Electrical shock can result in burns and life-threatening injuries. Before beginning installation and maintenance work, switch off mains voltage.



CAUTION

When using refrigerants that are not listed in chapter “Specifications”, injuries may occur due to higher pressures or leaks.



DANGER

Fires may occur when using combustible refrigerants. It is therefore forbidden to operate the device with combustible refrigerants.



WARNING

This device is not a safety-related installation. It may only be used in the commercial sector. The system must absolutely be equipped with an approved safety valve. If not observed, there is a danger of injuries and environmental damage caused by the discharge of refrigerants in the event that the system limits are exceeded.



WARNING

The discharge of refrigerants that are under pressure may cause eye injuries. Wear protective glasses during installation and maintenance work.

3. Specifications

- Supply Voltage: 100...240 VAC @ 47...63 Hz, 140...340 VDC
- Consumption Current: 200 mA max.
- Display: 3 Digit LED for LP
3 Digit LED for HP
- Output contact rating: 5A @ 250 VAC, not protected
- Cable specifications: 1.4 A @ 20° C
The specified switching currents must not exceeded and an additional, external protection must be adequately dimensioned.
- Analog output LP: 4...20 mA / 0...10 VDC @ -1...+19 bar
- Analog output HP: 4...20 mA / 0...10 VDC @ 0...50 bar OR FANCONTROL (see pt. 14)
- Operating temperature: -25°...+55° C RH 60 %
- Protection class: IP 65 according to IEC 60529
- Pressure connection: 7/16" - 20 UNF
- Refrigerants: R22, R134a, R404a, R407c, R407f, R410a, R448, R449, R507
- Storage conditions: Store the device in a clean and dry environment.
Keep the device in a place inaccessible to unauthorised persons.



4. Pressure Ranges

	Low pressure (LP) relative	High pressure (HP) relative
Pressure Range	-1...+19 bar / -14...+275 psi	0...50 bar / 0...725 psi
Accuracy	±0.5 % Fullscale	
	±0.1 bar / ±1.5 psi	±0.25 bar / ±3.6 psi
Overload warning	1 % overload (OFL is blinking & acoustic warning)	
	19.2 bar / 278 psi	50.5 bar / 732 psi
Overload	3 % overload (OFL in display & acoustic warning)	
	19.6 bar / 284 psi	51.5 bar / 746 psi
Physical Overload	40 bar / 580 psi	100 bar / 1450 psi
Burst pressure	60 bar / 870 psi	140 bar / 2030 psi

5. Overview

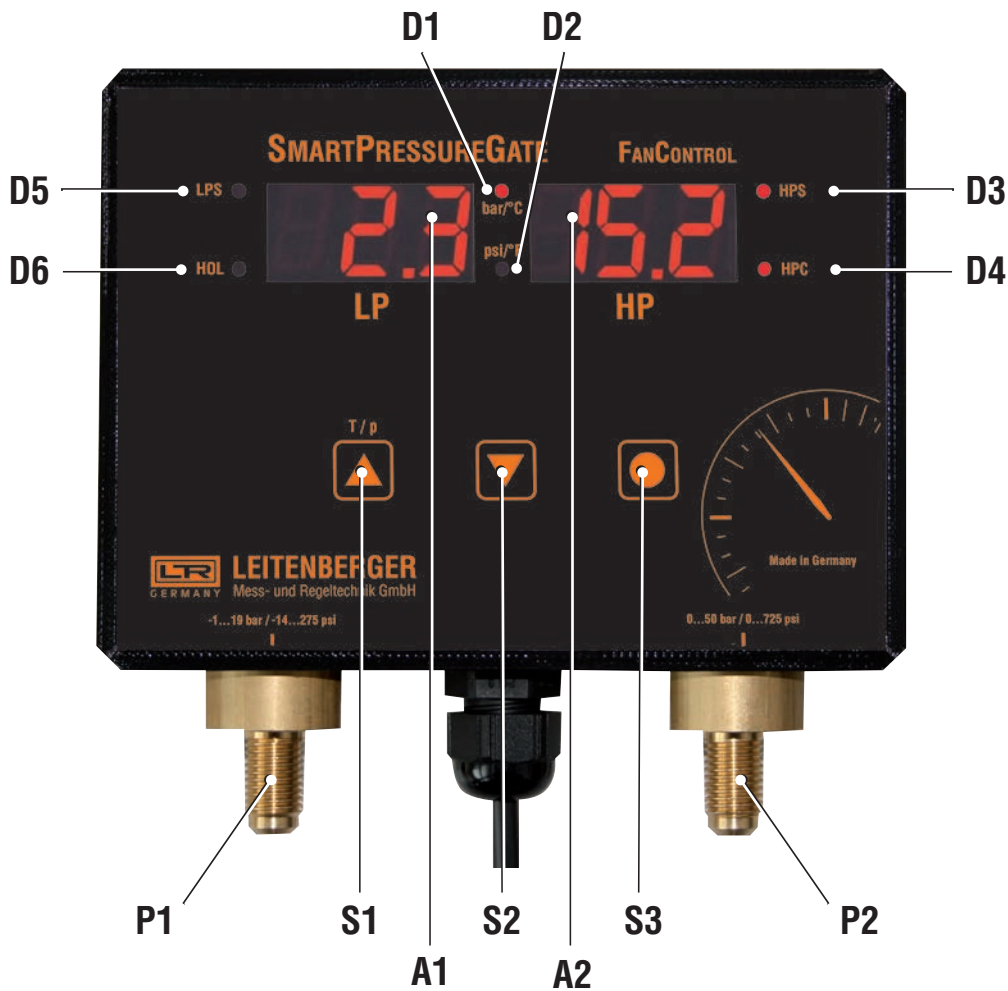

S1	Button 1	D3	HPS LED
S2	Button 2	D4	HPC LED
S3	Button 3	D5	LPS LED
A1	LP display	D6	HOL LED
A2	HP display	P1	LP sensor connection
D1	bar/°C LED	P2	HP sensor connection
D2	psi/°F LED		

6. Notation

HP (High Pressure):	High pressure from compressor.
LP (Low Pressure):	Low pressure to compressor (suction).
HPS (High Pressure Switch):	Compressor discharge pressure sensor in conjunction with the alarm switch.
Hdt (High Pressure Delay Timer):	HPS delay timer for switch OFF to prevent Hunting.
HPd (HP Switch Differential Pressure):	HP differential pressure value for HPS value to switch on the charger.
HPC (High Pressure Control):	Fan operating pressure value. Compressor discharge pressure sensor in conjunction with the condenser with fan motor control switch.
HIF (HP Differential Pressure):	Fan differential pressure value for HPC value. Compressor discharge pressure sensor in conjunction with the condenser with fan motor control.
LPS (Low Pressure Switch):	Fan operating pressure value. Compressor discharge pressure sensor in conjunction with the condenser with fan motor control switch.
LIF (LP Differential Pressure):	Fan differential pressure value for HC2 value. Compressor discharge pressure sensor in conjunction with the condenser with fan motor control.
Ldt (LP Delay Timer):	Compressor suction pressure sensor in conjunction with an automatic return control switch.
FAN (Fan control):	Activate or deactivate fan control via analog output
FHP (Fan High Pressure):	HP-pressure at which the maximum analog value is given out (active at „FAN ON“)
FLP (Fan Low Pressure):	HP-pressure at which the minimum analog value is given out (active at „FAN ON“)
FLL (Fan Low Level):	Minimum analog value of span at output in %
H-A (Manual Mode & Automatic Mode):	H: HPS reset after quitting button 3.
GAS:	Refrigerant gas selection.
Unt:	Pressure unit selection.
C-F:	Temperature unit selection.
ADD:	Setting the device address on the RS485 communication port for using ModBUS RTU.
RES:	Reset all changeable parameters to the default values.

7. Connection diagram

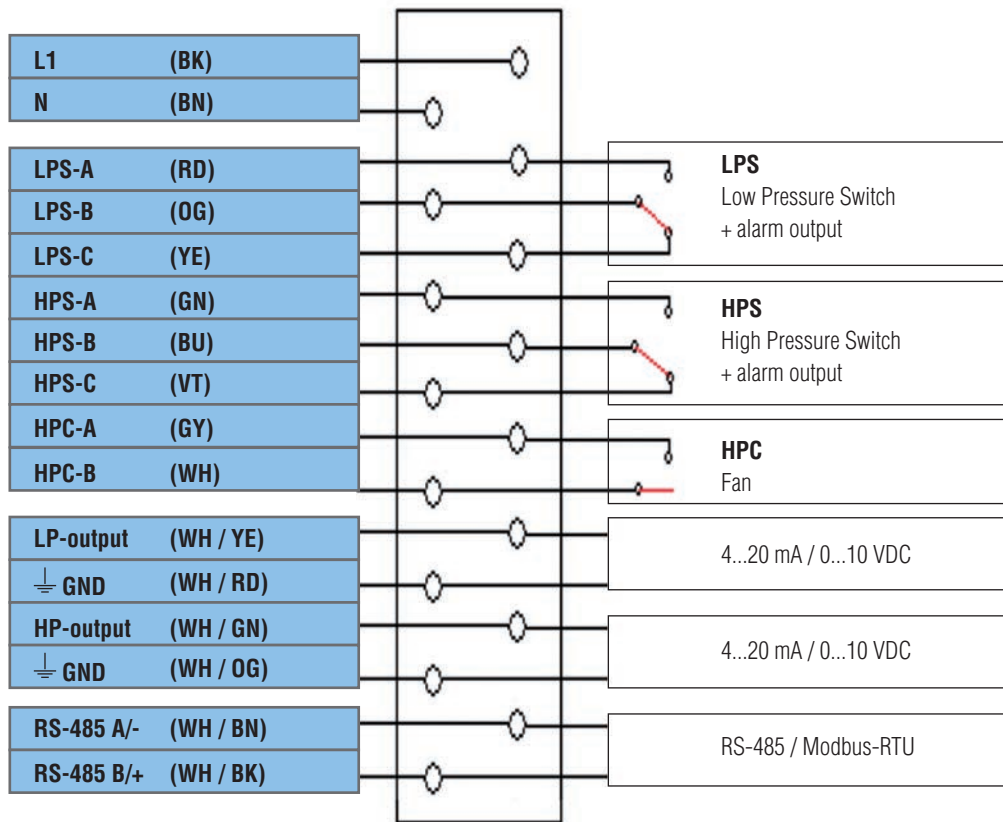

8. Status LEDs

HPS: switching state High Pressure Switch.
LPS: switching state Low Pressure Switch.
HPC: switching state High Pressure Control.
HOL: off → automatic mode active
 on → manual mode active
 blinking → setting mode active

bar/°C:
 - pressure mode: on → pressure unit is bar
 - temperature mode: on → temperature unit is °C

psi/°F:
 - pressure mode: on → pressure unit is psi
 - temperature mode: on → temperature unit is °F

9. Operating



Pressure mode:

In this mode, the pressures LP an HP are displayed in the selected unit.

Temperature mode:

By pressing the button  the pressure mode and the temperature mode can be changed. After 20 seconds the temperature mode will be selected automatically.

Setting mode:

By pressing and holding the button  the setting mode will be selected. With the buttons  and  the parameters can be changed. By short pressing in single steps and by holding the buttons at increased speed.

By briefly pressing the button you can navigate in the menu:

- PAS  ↓ →  or  in single steps →  → to the next digit
 holding for quitting or skipping the password
 check password, if the password matches you can change the following parameters
- HPS  ↓ →  or  0.0...50.0 bar in 0.1 bar steps / 0...725 psi in single steps
- Hdt  ↓ →  or  0...200 s in single steps
- HPd  ↓ →  or  0.0...50.0 bar in 0.1 bar steps / 0...725 psi in single steps
- HPC  ↓ →  or  0.0...50.0 bar in 0.1 bar steps / 0...725 psi in single steps
- HIF  ↓ →  or  0.0...50.0 bar in 0.1 bar steps / 0...725 psi in single steps
- FAN  ↓ →  or  ON/OFF
- FHP  ↓ →  or  0.0...50.0 bar in 0.1 bar steps / 0...725 psi in single steps
- FLP  ↓ →  or  0.0...50.0 bar in 0.1 bar steps / 0...725 psi in single steps
- FLL  ↓ →  or  0...100 % in single steps
- LPS  ↓ →  or  -1.0...19.0 bar in 0.1 bar steps / -14...+275 psi in single steps
- LIF  ↓ →  or  0.0...20.0 bar in 0.1 bar steps / 0...290 psi in single steps
- Ldt  ↓ →  or  0...200 s in single steps
- H-A  ↓ →  or 

- engLish
- GAS ↓ → ▲ or ▼
 - UNT ↓ → ▲ or ▼
 - C-F ↓ → ▲ or ▼
 - ADD ↓ → ▲ or ▼ 0...255 in single steps
 - RES ↓ → ▲ or ▼ holding → reset all changeable parameters to default values
 - END ↓ → ▲ or ▼ → end setting mode, switch to pressure mode
Setting mode starts from beginning at HPS

The setting mode will be leaved automatically if no button is pressed for 20 seconds and the pressure mode will be selected. By pressing and holding  the setting mode will be leaved and the pressure mode will be selected.

10. Parameters

Label	Name	Threshold value	Standard value
HPS	High Pressure Switch	0.0...50 bar / 0...725 psi	30.0 bar / 435 psi
Hdt	Delay Timer for HPS Data	0...200 s	0 s
HPd	Differential Pressure value for HPS Data	0.0...50.0 bar / 0...725 psi	3.0 bar / 43 psi
HPC	Fan Pressure Control	0.0...50.0 bar / 0...725 psi	20.0 bar / 290 psi
HIF	Differential Pressure value for HPC Data	0.0...50.0 bar / 0...725 psi	5.0 bar / 73 psi
FAN	Fan Control	ON/OFF	OFF
FHP	Fan High Pressure (HP)	0.0...50.0 bar / 0...725 psi	20.0 bar / 290 psi
FLP	Fan Low Pressure (HP)	0.0...50.0 bar / 0...725 psi	5.0 bar / 73 psi
FLL	Fan Low Level	0...100 %	15 %
LPS	Low Pressure Switch	-1...-19 bar / -14...+275 psi	7.0 bar / 102 psi
LIF	Differential Pressure value for LPS Data	0.0...20.0 bar / 0...290 psi	2.0 bar / 29 psi
Ldt	Delay Timer for LPS Data	0...200 s	0 s
H-A	Selection Mode for Automatic & Manual	A: automatic / H: manual	A
GAS	Select the gas type	R22, R134a, R404a, R407c, R407f, R410a, R448, R449, R507	R22
Unt	Select the pressure unit	bar, psi	bar
C-F	Select the temperature unit	°C, °F	°C
Add	Communication Adress for RS-485	0...255	2
RES	Reset all parameters to default values	---	---
End	Press the arrow button to exit	---	---

11. Switching characteristics HPC

HPC with the following setted parameters:

HPC: 20 bar

HIF: 5 bar

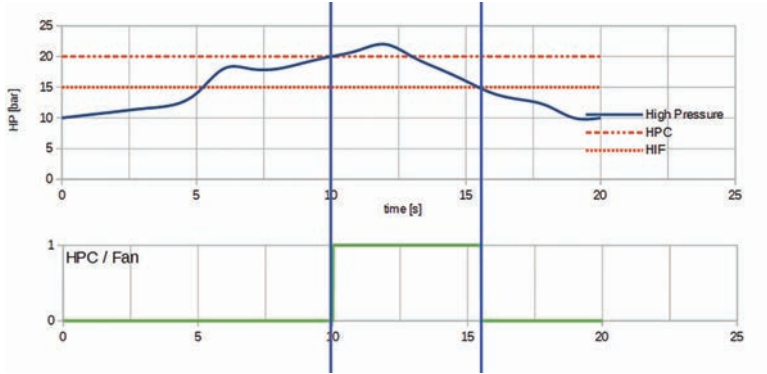

12. Switching characteristics LPS

LPS with the following setted parameters:

LPS: 10 bar

Ldt: 3 seconds

LIF: 2 bar

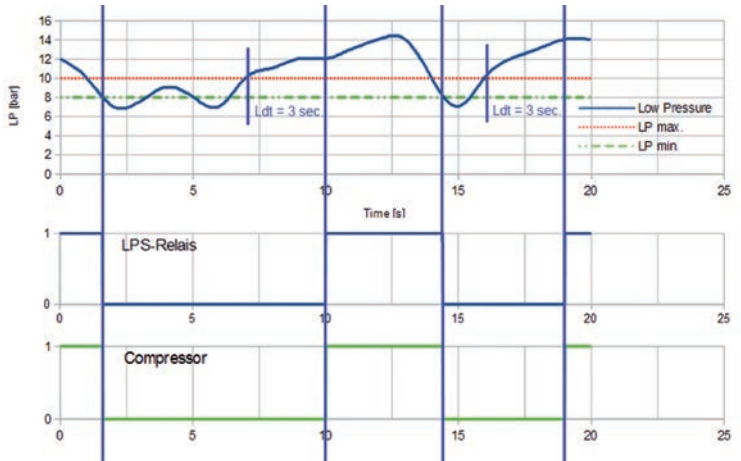

13. Switching characteristics HPS

HPS with the following setted parameters:

HPS: 30 bar

Hdt: 3 seconds

Hpd: 3 bar

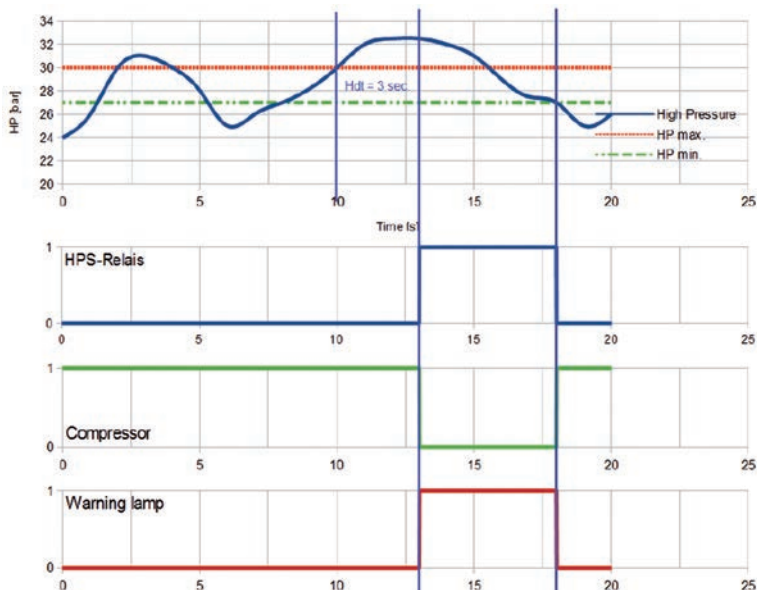

14. Fan control

Analog output FANCONTROL with the following setted parameters:

FHP: 18 bar

FLP: 6 bar

FLL: 20 %

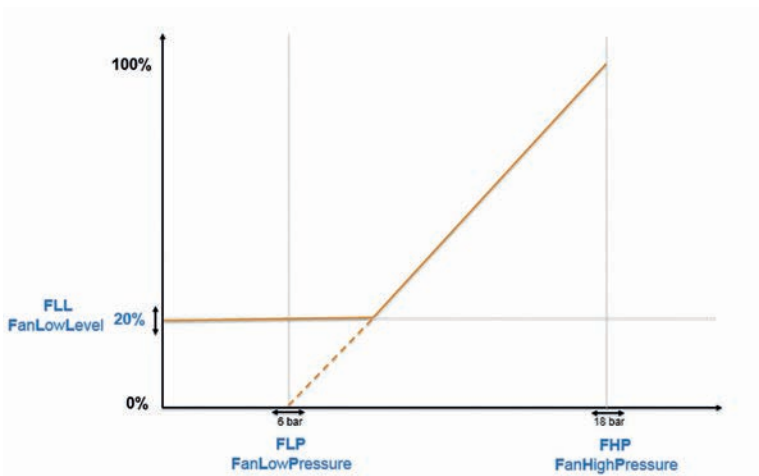

15. RS-485 (Modbus RTU)

Data Communication: RS485, Start-Stop synchronized serial interface
 Baudrate: 9600 bps
 Data lenght: 8 bit data
 Stop bit: 1 Stopbit
 Parity: None parity

For further information please call/contact the manufacturer (for telefon number/adrsess see below).

16. Disposal

Old devices must not be disposed of with household waste.
 For disposal, return the old device to the dealer where it was purchased.
 The device must be disposed of in accordance with legal regulations.



17. Wall mounting

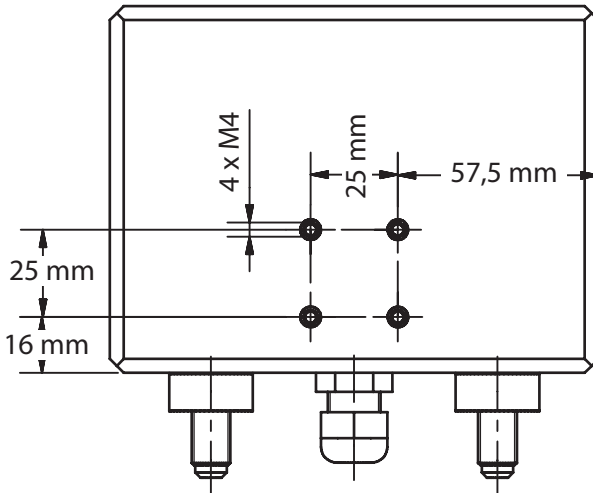

LEITENBERGER

Mess- und Regeltechnik GmbH

Bahnhofstraße 32 / 33

72138 Kirchentellinsfurt

Germany

www.leitenberger.de / lr-thermometer.de



+49 (0)7121/908-0



+49 (0)7121/908-200



mrt-info@lr-germany.de



ISO 9001 : 2008
Registrier-Nr.
12 100 24343 TMS