



Electric Valves

for Refrigerant Control

10 FEATURES AND BENEFITS

- Step motor operated for precise control
- High resolution drive assembly - 0.0000783 inches per step
 - Suitable for hot gas, liquid and suction vapor application
 - Corrosion resistant materials used throughout
 - Field proven reliability
 - Low power consumption - 4 watts
- Copper ODF connections and brass SAE connections for ease of installation
 - Compatibility tested with most CFC, HCFC and HFC refrigerants and oils
 - Hardened or self-lubricating materials used for long life
 - High linear force output

TABLE OF CONTENTS

The Refrigeration System.....	1	Superheat.....	10
Mechanical Valves.....	2	Pressure Transducers.....	10
Electric Valve Basics.....	2	Pressure-Temperature Tables.....	10
Types of Electronically Controlled Valves	2	Temperature Sensors.....	11
Step Motors.....	3	Discharge Air or Water Control.....	11
Step Theory	3	Applications	11
Digital Linear Actuators - DLAs.....	4	Air Conditioning and Refrigeration Systems	12
Resolution	4	Multiple Evaporator/Variable Capacity Systems	12
Bipolar Step Motor Specifications.....	5	Split Heatpump Systems.....	12
ESX Technical Specifications.....	5	Ice Machine Systems.....	12
Hardware.....	6	Constant Evaporator Pressure.....	12
Software.....	7	Control of Electric Evaporator Pressure Regulators - EEPs.....	13
Initialization.....	7	Control of Electric Discharge Gas Bypass Valves - EDBVs.....	13
Feedback Loops.....	8	Heat Reclaim Applications.....	13
PID Control & Algorithms.....	8	Temperature Control & Interface Board	13
Proportional Control.....	9	Trouble Shooting and Failure Modes.....	13
Integral Control.....	9	Nomenclature and Capacity Information	15
Derivative Control.....	9	Glossary.....	16
Control of Electric Expansion Valves - EEVs.....	10		

THE REFRIGERATION SYSTEM

Vapor compression cycle mechanical refrigeration has been in existence for over 100 years and is expected to remain the basis of commercial refrigeration for the foreseeable future. The refrigeration system is a closed system where the process of absorbing and rejecting heat is performed by the alternate compression, condensation and evaporation of a working fluid. In its simplest form the system consists of a compressor, condenser, expansion device, evaporator and interconnecting piping.

The heart of the system is the compressor since it pumps the refrigerant. Its function is to receive

low pressure and temperature refrigerant vapor from the evaporator and compress it into high pressure and temperature refrigerant vapor. The high pressure vapor is then converted into a liquid phase in the condenser. The condenser performs this function by removing heat from the vapor and rejecting the heat to air or water. The liquid, which remains at a high pressure, passes through the expansion device, experiences a pressure drop, and becomes a low pressure, two phase (liquid and vapor) mixture. This refrigerant mixture returns to the vapor phase in the evaporator by absorbing heat from the medium being cooled. The low pressure, low temperature vapor then returns to the compressor, and the cycle begins again.

MECHANICAL VALVES

The means to create the pressure drop necessary for the evaporation of the refrigerant has evolved over the years. The first method was simply a hand valve set to a particular flow and load condition. Its usefulness was limited by the fact that it had to be manually reset for each change in system load.

Capillary tubes, small internal bore pipes, are used to create a pressure drop by having high internal flow friction. Their ability to follow load is very limited. A similar idea was used in the fixed orifice. A very small hole is used to create the necessary pressure drop. Again, load following ability is slight.

An early type of system is the flooded type. In flooded systems the evaporator is a vessel containing refrigerant, and tubes containing the air or water to be cooled are submerged in the liquid. Float devices on the incoming or outgoing refrigerant stream were relatively successful, but were suitable for fixed level use only. Float systems were also prone to oil logging in the evaporator due to the low velocities of the refrigerant flow.

Advances in the area of mechanical valves led to automatic expansion valves. Automatic expansion valves maintain a pressure in the evaporator, and open in response to a drop in suction pressure. While able to follow the load better than fixed restrictors or capillary tubes, their operating characteristics are sometimes opposite those needed for an efficient system.

The most efficient and successful mechanical control of refrigerant is undoubtedly the thermostatic expansion valve (TEV). The TEV works by measuring and controlling superheat in the evaporator. Superheat is a direct measure of the work done, or heat absorbed, by the evaporator. Controlling superheat allows the TEV to meter the proper amount of refrigerant into the evaporator under all load conditions, and still prevent floodback from damaging the compressor.

An ideal refrigerant control device would be nonrefrigerant specific, have a very wide load range, be able to be set remotely, and control temperature directly. Electronically controlled valves meet these requirements.

ELECTRIC VALVE BASICS

In current designs, the electronics controlling the valve are separate from the valve itself. The correct term to describe the valves is therefore electroni-

cally controlled electric valves. For convenience, the balance of this discussion will use the term electric valve.

Since electric valves are assigned their function in the system by the software in their controller, an electric valve can be used anywhere in the system; as an expansion valve, discharge gas bypass valve, evaporator control valve, heat reclaim valve, head pressure control valve or crankcase pressure control valve.

TYPES OF ELECTRONICALLY CONTROLLED VALVES

Four basic types of electric valves have been offered to the marketplace; solenoid or pulse, analog, heat motor and step motor.

Solenoid valves are commonly used as shutoff valves and are simple in design. When a coil surrounding a plunger is energized, the magnetic field lifts the plunger. Refer to Figure 1. The valves are designed to have the plunger open a port when lifted by the magnetic field. This type of valve is either open or closed and has no ability to modulate flow. To be successful as a modulation valve, a solenoid must be opened and shut rapidly in response to a signal generated by a controller. The term Pulse Width Modulation (PWM), or simply Pulse, is used for this design. Mechanical limits of the design confine the load following ability, or resolution, to a very narrow range. Because of the sudden starts and stops of the refrigerant flow created by this type of valve, "water hammer" or vibration may occur and cause valve or system damage. Applications of Pulse valves have been moderately successful, however long range effects on valves and systems must be considered.

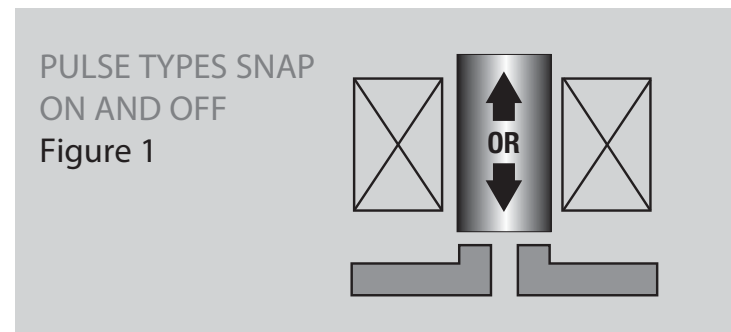

Analog valves, shown in Figure 2, are related to the pulse style valve in that they are basically a solenoid design. The main difference is that the coil and plunger are specifically designed to create a variable magnetic field. A stronger field will open the valve more, a weaker field will allow the valve to close. Analog valves are almost infinitely variable in their modulation, but the programming needed to accurately position the plunger is very complex. The valves are

subject to high hysteresis, internal friction, residual magnetism and poor repeatability. Properly designed analog valves, such as the Sporlan CDA type, have been very successful in transport refrigeration but are uncommon in other applications.

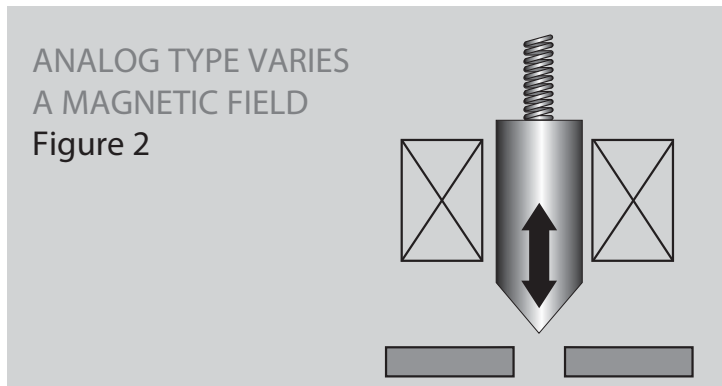

Heat motor valves are similar in construction to thermostatic expansion valves. Refer to Figure 3. TEVs have a bulb filled with a substance, usually a mixture of refrigerants or other fluids, that expand when heated. The heat causing this expansion, and subsequent opening of the valve, is transferred from suction piping to the bulb. In a heat motor valve, a small electric heater immersed in the bulb fluid is energized by variable amounts. The heat generated expands the bulb fluid to modulate the valve.

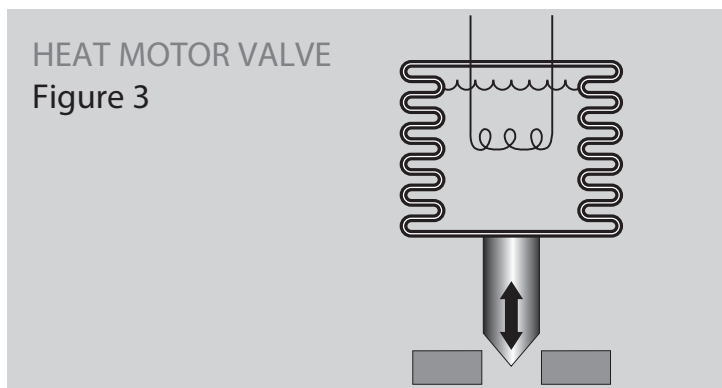

Step motor valves, as shown in Figure 4, are the most sophisticated design. In this type of valve a small motor is used to open or close the valve port. The motor that is used does not rotate continuously, but instead, rotates a fraction of a revolution for each signal sent by the controller. These discrete "steps" give the motor its name. The number of step signals sent by the controller is "remembered" by the controller, and the controller can return the valve to any previous position at any time. This repeatability is almost absolute and extremely fine control can be obtained. The digital circuitry used by step motor controllers can respond quickly and accurately. The ESX is run at 83 steps per second while larger Sporlan step motors are run at a 200 steps-per-second rate and can be made to return to an exact position. Sporlan electric valves are designed for 500 to 6386 steps, so extraordinary resolution or control of flow is possible.

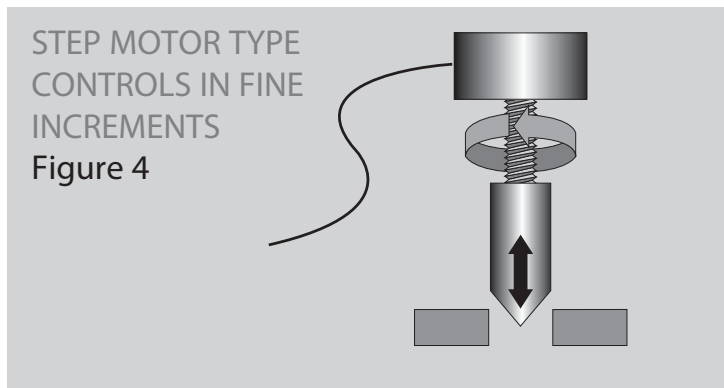

STEP MOTORS

Step motors have existed for many years but were limited to very specialized, and usually expensive, applications. When the personal computer industry expanded and automobiles became more electronically controlled, the need for small, reliable and inexpensive steppermotors increased dramatically. Step motors permitted the repeatable precision movement needed for high speed printers and computerized engine management. In the 1980s Sporlan experimented with step motor technology, and production step motor valves were offered in the early 1990s. Initial designs incorporated unipolar motors, but later designs employed the more efficient bipolar style.

STEP MOTOR THEORY

Unlike traditional motors that will rotate as long a the proper power is supplied, step motors rotate a known amount of arc and then stop. When power is removed and then reapplied the step motor will rotate another fixed amount, or step, and again stop. This cycle may be repeated infinitely, within mechanical limits, in either direction. While seemingly complex, this start/stop motion is mechanically simpler than induction or commutated motors.

Step motors, like almost all motors, are based on the magnetic principal that opposite poles attract and like poles repel. These poles are called North (N) and South (S).

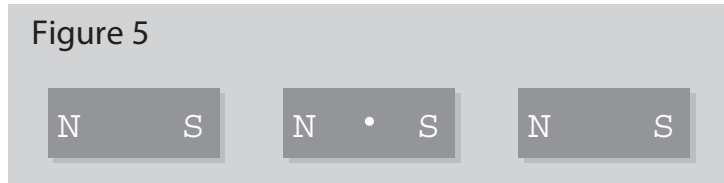

If the center magnets above and below, are free to rotate, then the previous orientation will always occur. If electromagnets are used, then a pivoted magnet or rotor can be made to align with the magnetic fields created when the electromagnets are energized.

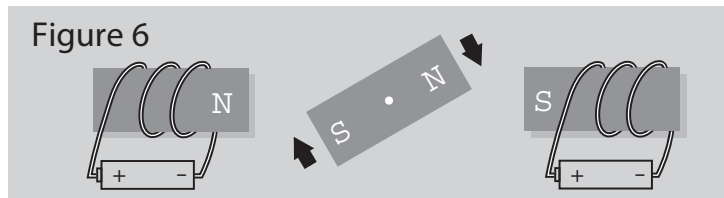

If power is left on, the magnetic poles will align and no further motion will take place.

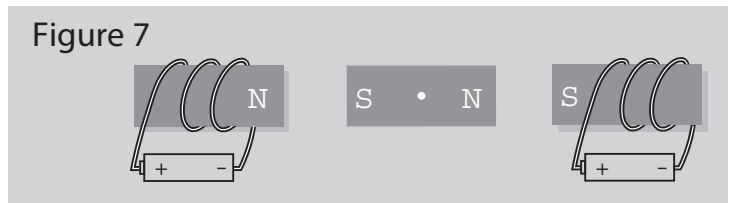

If multiple groups of electromagnets are placed around a freely rotating permanent magnet rotor, and each is energized in series, then the rotor will step to each alignment position and a step motor is created.

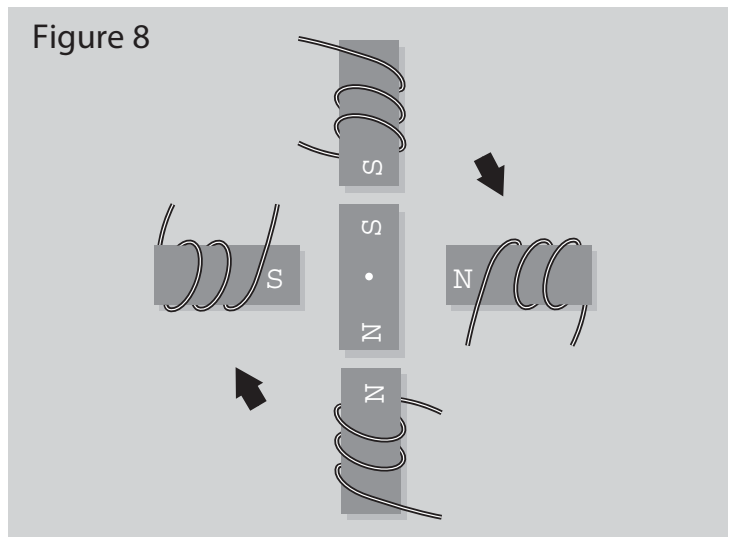

The above is a simple example, in reality step motors may have 24 to 100 virtual electromagnets arranged around the rotor. Simple arithmetic shows these motors to have 15° to 3.6° step angles or increments of rotation.

There are two general types of step motors: unipolar and bipolar. In a unipolar style, like the Sporlan ESX motor, current flows in only one direction. In the case of the Sporlan ESX valve motor, the gray lead is always at +12 volts DC and each of the other four colors is in turn connected to a ground. Drive circuitry is simpler, but torque and efficiency are lower than bipolar designs. However, unipolar motors are useful in small capacity valves like the Sporlan ESX. A bipolar motor, such as used in all other Sporlan valves, is powered by signals that change polarity. For the first step the black lead may be negative while the white is positive, for the second step the black becomes positive while the white becomes negative. This push/pull increases torque and efficiency for motor size and power input. Bipolar is the style of choice for all larger step motor valves. Figure 11 on page 6 reflects bipolar driver circuitry.

DIGITAL LINEAR ACTUATORS - DLAs

Small increments of rotation may be useful in print head drives or for signaling purposes, but often a linear movement is more desirable. In the case of electric refrigerant control valves, not only is linear motion

needed, but significant linear force is also needed to close a port against high pressure. While small tonnage valves may successfully use direct drive larger valves may not. The solution to both these needs is a Digital Linear Actuator, or DLA. DLAs are used to convert rotation to a push/pull, often with a large increase in output force. The force increase is derived from a simple geartrain and may account for a five-fold increase in mechanical advantage. This torque increase is used to turn a drive screw or threaded shaft. A drive nut, or coupling, is threaded onto the shaft but prevented from turning by keyways, or specially shaped guides. Since the drive nut cannot turn, it must move forward or backward, depending on the rotation of the threaded shaft.

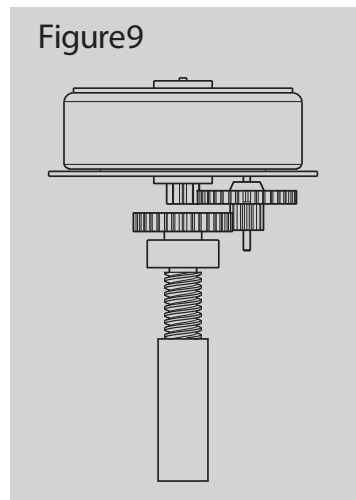

RESOLUTION

Resolution is defined as the ability of the valve to meet flow requirements accurately. In a Pulse type valve only two stages of resolution are possible, fully open or fully closed. Theoretically, if a valve needs to meet a 50% load then it may remain closed for half the time and be fully open for half the time. The control of temperature and superheat will be "jumpy" as the valve alternately floods and starves the evaporator. If the swings are 6°, we say the resolution is ±3°. An Analog Electric Valve or TEV has better resolution because it opens and closes smoothly. In both valves, however, there is hysteresis.

Hysteresis is the internal friction of any system. In a TEV it takes more force or pressure to deform the diaphragm in the opening direction than in the closing direction. This hysteresis has an effect on the resolution of the TEV, and limits its ability to precisely meter refrigerant over widely changing head pressure and evaporator load conditions. Balanced ported TEVs, like Sporlan BF and O series valves, have a much greater ability to follow load than conventional TEVs, but still not to the extent that EEVs can.

The resolution of an Electric Expansion Valve or EEV is governed by the stroke and number of steps in that stroke. Sporlan offers valves in a variety of sizes for a multitude of applications. All valves except the ESX use the same motor/driver assembly, but physical size limits the number of steps used in the different valves. ESX electric expansion valves have 500 nominal steps of stroke, small tonnage SER electric expansion valves have 1596 nominal steps of stroke, and CDS-16,

SDR-4 and large tonnage electric expansion valves have 6386 nominal steps of stroke. The piston or pin of the larger valves moves the same linear distance for each step, .0000783 inches. This extremely small change in the distance the pin moves away from the seat is reflected in the minute amount of refrigerant flow increase or decrease. Pulse type valves, with only open and shut capabilities, will have inferior resolution. A simple analogy is comparing an on/off light switch which has only two steps of resolution and a dimmer switch which may have thousands.

Inductance:

$62 \pm 20\%$ mH per winding

Maximum Power Input:

4 watts

Recommended Step Rate:

200 steps per second, other rates must be approved.

Number of Steps:

6386, 3193 or 1596 depending on valve model

Resolution:

.0000783 inches/step (0.002 mm/step)

MOPD

620 PSI (42 Bar)

MRP

620 PSI (42 Bar)

Dielectric Resist:

650 ± 50 VRMS for 1 second

Linear Output Force at Valve Driver:

45 lbf. (200 N) minimum

Detent Force at Valve Driver:

130 lbf. (578 N) minimum

Media Temperature:

-40-225°F (-40-107°C)

Ambient/Storage Temperature:

-40 to 225°F (-40-107°C)

ESX TECHNICAL SPECIFICATIONS

Device Description

4 phase, 24 pole, unipolar, permanent magnet step motor expansion valve for halocarbon refrigerants

Actuator Type

Dry stator: replaceable, rotatable, 10 position

Wet rotor: fully hermetic body

Valve Orifice Sizes and Nominal Capacity

0.055" (1.4 mm): 1.5 tons R-22 (4.5 kW)

0.071" (1.8 mm): 3.0 tons R-22 (7 kW)

0.094" (2.4 mm): 5.0 tons R-22 (15 kW)

Construction

Stator: Copper, steel, nylon

Body: Brass, copper, stainless steel

Figure 10

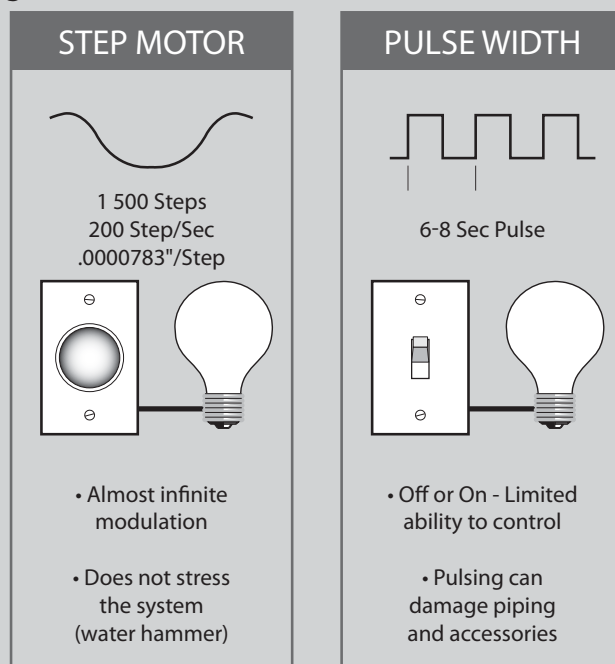

Larger Sporlan step motor operated valves all use a common bipolar motor driver assembly, shown below. ESX specifications follow:

SPECIFICATIONS

Motor Type:

2 phase permanent magnet, 2 coil bipolar

Compatible Refrigerants

R-22, R-134a, R-404A, R-407C, R-507, R-410A

Supply Voltage:

12 VDC, -5% +10%, measured at the valve leads

Connections:

4 lead, 18 AWG, PVC insulation jacketed cable

Phase Resistance:

75 Ohms per winding $\pm 10\%$ at 72°F (22°C)

(SER - 100 Ohms $\pm 10\%$ at 72°F (22°C))

Current Range:

.131 to .215 amps/winding

.262 to .439 amps with 2 windings energized

Compatible Refrigerants
 R-22, R-134a, R-404A, R-407C, R-507, R-410A

Compatible Oils
 Mineral, polyolester, alkylbenzene

Resolution
 500±20 steps; 0.104" (2.64 mm) travel

Step Rate
 30 pulse/sec minimum to 83.5 pulse/sec maximum

Full Motion Transit Time
 16.7 sec @ 30 pulse/sec
 6 sec @ 83.5 pulse/sec

Valve Shutoff
 140 cc/min @ 150 psid (10.3 Bar)
 Metal/metal seating
 Over/under drive protected

Stator Voltage
 12 VDC ±10%

Power
 4 watts nominal during transit
 5.8 watts maximum
 No holding power required

Stator Insulation
 Class E; 500 V no dielectric breakdown

Flow Path/Connections
 90° flow pattern; biflow capable
 Extended copper connections

Installation orientation
 Vertical to horizontal recommended

MOPD
 500 psi (34.5 Bar) forward flow (side inlet)
 See Table 1 for reverse flow (bottom inlet)

Table 1

ESX MOPD		
Valve Type	FORWARD FLOW SIDE INLET	REVERSEFLOWBOTTOMINLET
ESX-14	500 psi	400 psi
ESX-18	500 psi	300 psi
ESX-24	500 psi	125 psi

Max. Working Pressure
 650 psig (44.8 Bar)

Burst Pressure
 3250 psig (224 Bar)

Media Temperature
 -40°F to 155°F (-40°C to 70°C)

Ambient / Storage Temperature
 -25°F to 140°F (-30°C to 60°C)

Minimum Life
 250,000 CYCLES

Corrosion Resistance
 100 hr. ASTM B-117 salt spray

Weights
 Body: 0.17 lb (77 g)
 Stator: 0.34 lb (154 g); without cable

Phase Resistance
 46± 4 Ohms each Phase to common (gray) wire

Discussion on page 4 pointed out the difference between a unipolar and bipolar motor.

HARDWARE

Actual control hardware for the valves may take a variety of forms. The most complex and expensive utilizes discrete or individual transistors for each switching function. This design requires the use of eight transistors, labeled Q1 through Q8, connected as shown in the schematic Figure 11.

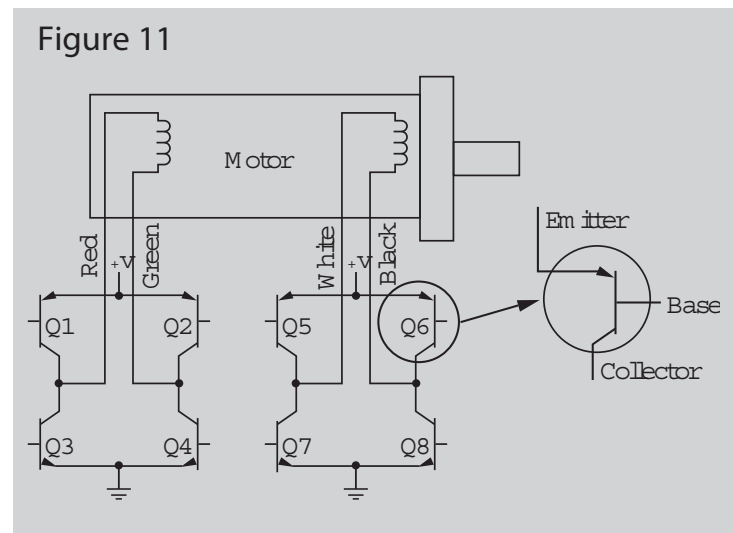

Transistors are simply solid state switches. Solid state means they are fabricated from a solid chip of silicon and have no moving parts. They act as switches or relays by using a small electrical signal to turn a large signal off and on. In the symbol above, the small signal enters the "base" lead and allows flow from emitter to collector. The microprocessor, or small computer, used in the controller has the ability to sequence signals to the "base" of each transistor. As shown in the

table below, this sequence of signals turn the transistors on and off in pairs, to step the valve open or shut. Transistors are available as bipolar (not to be confused with motors of the same name) which control current, and MOSFET (Metal Oxide Semiconductor Field Effect Transistor) which control voltage. In each type there are also transistors that are used to turn off the supply voltage or, the ground. Full exploration of these differences are beyond the scope of this explanation but drive circuitry using each of these types have been used successfully.

The actual drive sequence for Sporlan valves is shown in Table 2.

Table 2

BIPOLAR DRIVE SEQUENCE				
STEP	BLACK	WHITE	RED	GREEN
1	12 volts	0 volts	12 volts	0 volts
2	0 volts	12 volts	12 volts	0 volts
3	0 volts	12 volts	0 volts	12 volts
4	12 volts	0 volts	0 volts	12 volts
1	12 volts	0 volts	12 volts	0 volts

Used for all Sporlan Step Motor Valves except ESX

UNIPOLAR DRIVE SEQUENCE				
STEP	ORANGE	RED	YELLOW	BLACK
1	0 volts	12 volts	12 volts	12 volts
2	0 volts	0 volts	12 volts	12 volts
3	12 volts	0 volts	12 volts	12 volts
4	12 volts	0 volts	0 volts	12 volts
5	12 volts	12 volts	0 volts	12 volts
6	12 volts	12 volts	0 volts	0 volts
7	12 volts	12 volts	12 volts	0 volts
8	0 volts	12 volts	12 volts	0 volts
1	0 volts	12 volts	12 volts	12 volts

Gray is common and connected to 12 volts at all times.
Used for ESX valves only.

As each phase is energized in sequence, the shaft of the motor will move in the direction indicated by one step. The sequence repeats as many times as needed to achieve the position calculated by the external electronic controller.

Reversing the sequence changes the direction of the motor shaft, proper sequencing allows the valve to open and close without loss of steps.

Permanent magnet step motors, such as those used by Sporlan, will maintain position when power is removed. This "brake" effect allows controllers to be simpler and use less energy. Sporlan suggests that all voltage be removed from the motor when not actively stepping to minimize heat and power consumption. Over 130 pounds of force (578 newtons) are needed to cause the motor to turn when not powered. This is not possible in any proper application of the valve.

SOFTWARE

The valves, with their motors and wiring, and controllers, with their transistors and microprocessors, are grouped together as "Hardware". To make the hardware perform a function, a set of instructions must be given to the microprocessor. This set of instructions is called "Software" and certain "routines" must be incorporated to make valve control possible.

Most step motor valves are designed without internal intelligence or feedback, that is, they move only in response to controller signals. The valves maintain their position when no signals are received and valve position is stored in controller memory. When the valve is given a signal to change position the controller keeps track of the change, however, the controller does not directly "know" whether the valve has changed position. To make this form of control effective, two control routines must be implemented: initialization and feedback loops.

INITIALIZATION

Initialization occurs when the valves are powered up for the first time, and sometimes when a large change to the system is made, e.g. closing for defrost. When the controller and valve combination are first powered together, the control does not know the valve position. To initialize, the controller sends out a stream of closing steps greater than the total number of steps in the valve stroke. This will assure that the valve is closed. This closed position becomes the "0" (zero) position of the valve used in all subsequent controller calculations.

This series of extra steps is called "overdriving", and the valves have been designed to accept this without damage. The actual number of overdriving steps is dependent upon the valve used. Sporlan valves, while all using the same motor/driver, are available in a variety of configurations and sizes. The number of nominal or flow steps changes from 500 for the ESX to 3500 for the small SER expansion valve and SDR-3(X) valves and 6386 for all others. The number of flow steps is the range over which the valves can best control flow. The actual number of mechanical travel steps is larger and dependent on manufacturing tolerance. To assure that the valves are completely closed during initialization, the number of steps shown in table 3 should be used.

Table 3

INITIALIZATION	
VALVE TYPE	STEPS
ESX	500
SER 1.5 TO 20	3500
SEI-30 & 50	6500
SEH-100	6500
SEH-175	6500
CDS-9	6500
CDS-16	6500
SDR-3 & SDR-3X	3500
SDR-4	6500

Since the valves have been designed to accept over-driving steps without damage, an initialization of 7500 steps may be used on all valves.

Once the valve is fully closed and the controller knows the "0" valve position, the algorithm may be implemented with the aid of a feedback loop.

FEEDBACK LOOPS

Feedback occurs when the result of a process is sensed and the sensory information is used to modify the process. In simpler terms, when the controller opens the EEV too much, causing overcooling, the temperature sensor "feeds back" that information, and the controller closes the valve. Step motor valves could be designed with internal feedback that would report the actual position of the valve in number of steps open, however, this would be expensive and undesirable in terms of temperature control.

If a control algorithm were written with only references to absolute number of steps open, then changes in head pressure, liquid temperature, etc. would not be taken into account and control would be poor.

Instead, sensors are used to ascertain the effect of valve position on temperature and the position is changed to bring the sensed temperature closer to the setpoint.

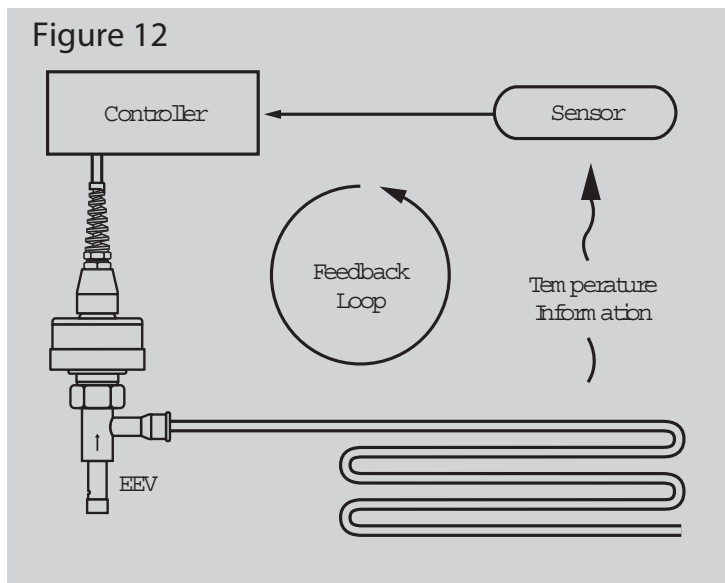

The feedback loop in Figure 12 is augmented by the use of a PID (Proportional Integral Derivative) algorithms as explained in the ALGORITHM section below.

PID CONTROL and ALGORITHMS

PID Control

In proportional control, actual temperature will approach setpoint, but because of various factors, may not reach setpoint in all instances. The difference

is called "offset". If offset were constant, as shown in Figure 13, then the difference could be programmed into the controller. In the real world, offsets change over time and with load conditions, so some means of correcting them must be used.

In integral control, the changing amount of offset is calculated by the control algorithm and is added to the setpoint. Integral control is often called "reset" control because of this characteristic. See Figure 14.

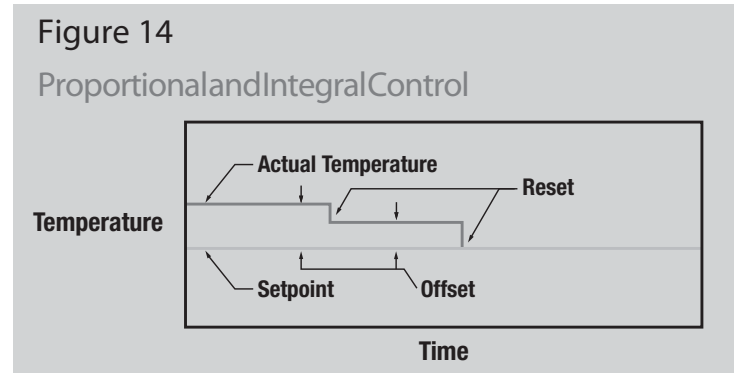
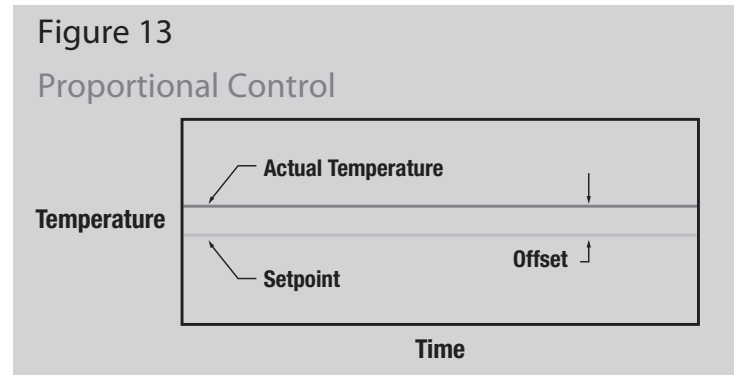

DERIVATIVE control looks at the slope of the curve of the temperature change. If the slope is steep the algorithm moves the valve faster or by a greater amount to meet the new conditions.

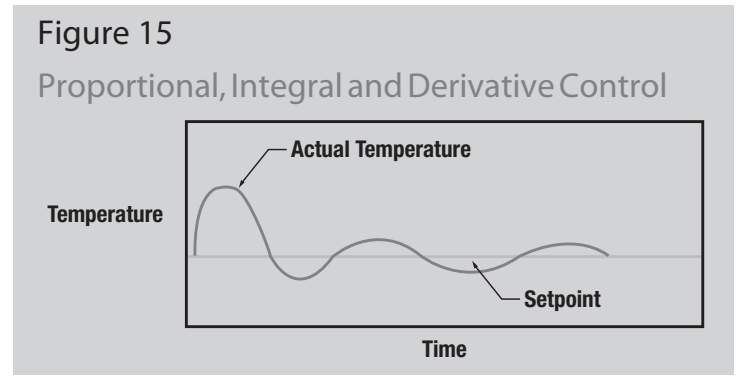

Algorithms that use Proportional, Integral and Derivative control can be very accurate. In many instances the algorithm can be made to "learn" its own coefficients for the three variables. Autotune PID controllers have this ability, however, they are generally only available for single point temperature control. Simple evaporator temperature or discharge gas bypass applications may lend themselves to this type of control, but complex functions such as superheat control are usually not available in off-the-shelf components. Since expansion valves, whether mechanical or electronic, are essentially superheat control devices,

controllers for them must measure superheat. This can be accomplished by the two temperature method or pressure-temperature method. See the discussion on Control of Electric Expansion Valves.

In either case, extensive testing is required to prove proper operation. Due to the expense of this testing, superheat algorithms are held secret by most control manufacturers.

Algorithms

Regardless of how the superheat is determined, the controller uses it in an algorithm to control the valve. An algorithm is simply a set of instructions. Algorithms are based on "if-then" statements, for example: "if superheat rises then open the EEV". Algorithms are usually created after testing is done to find the effect of various changes made to the system. For instance, a refrigeration system is set up with an EEV that can be opened and shut with a simple joystick controller. Measurements are taken of refrigerant flow, superheat, discharge air temperature, etc. as they relate to valve position. It is then possible to quantify changes in refrigerating effect in response to valve position. A "flow chart" for the algorithm is generated from this information. The chart begins to look like this:

- If superheat is 15°F then open valve 150 steps
- If superheat is 10°F then open valve 100 steps
- If superheat is 5°F then open valve 0 steps
- If superheat is 3°F then close valve 50 steps
- If superheat is 0°F then close valve 3000 steps

Notice that the above flow chart will only allow the valve to control to 5°F superheat, any higher superheats open the valve, lower superheats close the valve and 0°F superheat shuts the valve fully. As experience is gained in testing and controlling the valve, the flow chart can be made more complex and useful. One of the ways to do that is to introduce a user-chosen variable called "superheat setpoint".

PROPORTIONAL CONTROL

Programming language uses let statements and input statements to put a number into a variable like "X", and line numbers to allow loops:

- 10 Let "X" be superheat setpoint
- 20 Input "X"
- 30 Let "Y" be actual superheat
- 40 If X=Y then close valve 0 steps
- 50 If X > Y then close valve 1 step (setpoint higher than actual SH- close valve)
- 60 If X < Y then open valve 1 step (setpoint lower than actual SH- open valve)
- 70 Go to line 40

If programmed with the above, sooner or later, the valve will reach its setpoint. However, when used with a valve having 3000 to 6000 steps of resolution, it may take a long time to reach setpoint with the above algorithm. An actual algorithm would have many more instructions and would begin to incorporate predictive loops. The above algorithm is strictly proportional, that is, it will change the output (steps) directly in relation to input (superheat).

Most valve control algorithms are more complex, and incorporate other features, including integral and derivative coefficients.

INTEGRAL CONTROL

Any proportional control will experience some overshoot or undershoot – actual control temperature will be a little higher or lower than setpoint. Sometimes this overshoot or undershoot is due to system design, other times it is due to time lag in sensing, or valve movement. In addition, a valve with poor resolution is more prone to this type of hunting. Whatever the cause, a proportional algorithm can often be improved with the addition of an integral component. Integration senses the average deviation of actual temperatures or superheat from the setpoint. An offset is then applied to the valve position to compensate for any of the above factors. The offset is continually being changed in response to the load and system changes. An example of an integral command step is:

- 80 If average superheat for 30 seconds is 5°F high then open valve 20 steps.

DERIVATIVE CONTROL

A final parameter that can be added to a control algorithm, to assure the tightest temperature or superheat control, is the derivative function. In essence, the derivative function senses the rate of change in temperature or superheat and attempts to predict future valve positions. It does this by estimating the slope of the curve for the change in the temperature or superheat. If the derivative function senses that the change is rapid, meaning the slope is steep, then it will make changes of greater magnitude. If the slope is shallow, meaning the rate of change is slow, it will change valve position only slightly. An example is shown below.

- 90 If superheat has dropped .1 degrees in 5 seconds then close valve 10 steps.
- 100 If superheat has dropped 1 degree in 1 second then close valve 100 steps.

Algorithms, including the PID type above, begin with a theoretical basis but must be confirmed and fine tuned by experiment and test.

CONTROL OF ELECTRIC EXPANSION VALVES - EEVs

As previously explained, Electric Expansion Valves are divided into four types; pulse, analog, heat motor and step motor. The operation of each is unique and actual drive circuitry for each cannot be interchanged with any other type. The algorithm, or set of instructions, used to control any electric expansion valve will be similar and can be adapted for the different valves. Just as with traditional mechanical thermostatic expansion valves, EEVs are primarily superheat control devices. When using EEVs, the manner in which superheat will be sensed must be determined first.

SUPERHEAT

There are two basic schemes for sensing superheat. True superheat is a pressure-temperature relationship, specific to each refrigerant. When electronically derived, pressure-temperature superheat requires the use of a pressure transducer, a temperature sensor, and a pressure-temperature table or equation. Another, simpler, but less accurate measure of superheat, is the two temperature method.

In the two-temperature method the temperature is sensed at the inlet and at the outlet of the evaporator. The difference in temperatures is then assumed to be superheat. Refrigerants or blends with temperature glides may affect two-temperature superheat control. Ordinarily, superheat setpoints must be higher to overcome the effects of glide.

An advantage to two-temperature superheat is cost; pressure transducers are far more expensive than thermistors. Additionally, it works with any refrigerant without reprogramming. The temperature difference between the two sensors will indicate superheat no matter what the pressure-temperature relationship of the refrigerant.

The main disadvantage of the two-temperature method is the uncertainty that the inlet sensor is located properly. For the two-temperature superheat method to be accurate, the inlet sensor must be located in a position that has saturated refrigerant present at all times. Often, only flow testing of individual evaporators will provide the information necessary to establish the correct location. Failure to find, or use, the proper location can lead to poor control or compressor damage.

Sporlan will only provide two temperature controllers as special products to manufacturers who will test the applications.

PRESSURE TRANSDUCERS

Pressure transducers are available in a variety of ranges, inputs, outputs, and accuracies. When choosing a pressure transducer it is important that the device is refrigerant compatible and suitable for the pressures experienced in refrigeration systems. Typically, a pressure transducer is a three wire device. Two wires supply power, the third is an output signal. Generally as the pressure rises, the voltage sent out the signal wire rises. The controller uses this voltage to calculate the temperature of the refrigerant with the use of a pressure-temperature table encoded in the controller itself.

PRESSURE-TEMPERATURE TABLES

Pressure-Temperature tables are familiar to the Air Conditioning and Refrigeration industry and are available in many forms. To be useful to an electronic device, they are encoded in a "lookup table". This is nothing more than an area in the memory of the controller where the information is stored electronically.

When a P-T (pressure-temperature superheat) controller is used, the lookup table for the specific refrigerant used in the system must be programmed into the controller. As with mechanical TEVs, when pressure and temperature are used for superheat control, the refrigerant must be known. The controller cannot be used with a different refrigerant without internal changes or reprogramming. Since the lookup table for a refrigerant can be stored in a fairly small amount of electronic memory, some controllers have been programmed with a number of refrigerant tables. The proper table for the application is selected by a switch on the controller.

Another way the pressure-temperature relationships of one or more refrigerants are stored in the memory of a controller is by use of the "equation of state". The equation of state is a mathematical description of a refrigerant's properties. Since EEV controllers are small computers, they have the ability to process equations efficiently and quickly.

It is the controller designer's decision as to the best method of storing the P-T relationships. Once the pressure of the refrigerant is sensed and the lookup table is used to calculate the saturated temperature, only the real suction temperature must be sensed to determine the operating superheat. Suction temperatures are detected by temperature sensors.

TEMPERATURE SENSORS

Temperature sensors are available in different types. Most often, a thermistor is chosen because of availability, reasonable price and good accuracy. A thermistor is a solid state device that will change electrical resistance in response to a change in temperature. Other terms, such as PTC (positive temperature coefficient) and NTC (negative temperature coefficient) are sometimes used in thermistor literature, but that characteristic is not pertinent to this discussion. The change in resistance of the thermistor is used by the controller to calculate temperatures at the sensor location. The calculated temperatures are then used to generate superheat measurements, either by the pressure-temperature method or by the two-temperature method. Temperature sensors are also used to allow electric valves to directly control temperature.

DISCHARGE AIR or WATER CONTROL

A secondary routine in EEV algorithms may control the temperature of the discharge air or water directly. In this design, as long as superheat remains above some minimum value, temperature of the medium being cooled is the control setpoint. If superheat falls, the controller will resume superheat control and attempt to raise superheat to the set value. Once superheat is re-established, discharge temperature control is resumed. This type of algorithm may be suitable for some process applications, but has been found to be less desirable in supermarket display cases.

In a refrigerated display case with direct air temperature control, the efficiency of the EEV allows less of the evaporator to be used, but at a higher TD (Temperature Difference). Higher TDs on the evaporator may lead to an increase in frost and require longer or more frequent defrost periods. In general, EEVs using superheat control algorithms are less likely to build frost.

In systems with coils specifically designed for EEV control, or with provisions to float suction pressures, EEVs may increase control precision while saving energy.

APPLICATIONS

EEV valves provide precise control of either liquid or vapor refrigerant to satisfy requirements for flow controls on a wide range of refrigeration and air-conditioning systems. Because the valves are electronically controlled, they have the ability to control pressure, temperature, superheat and many other system characteristics.

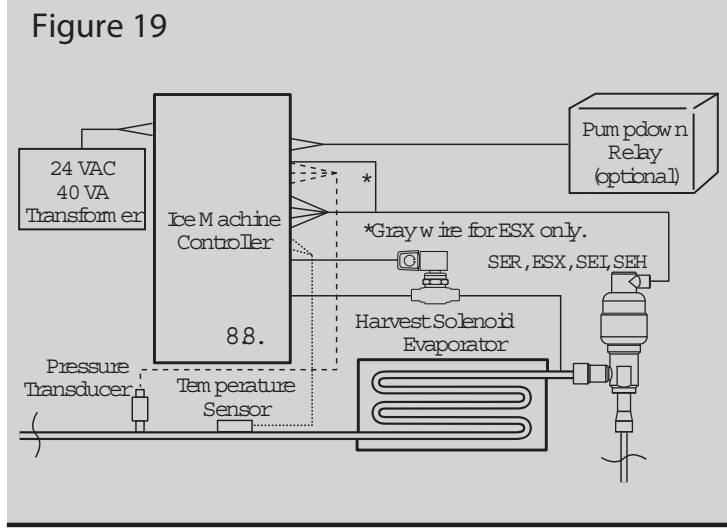
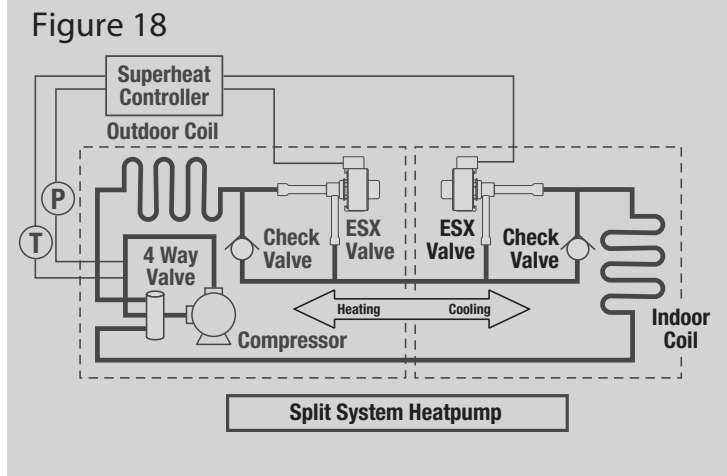
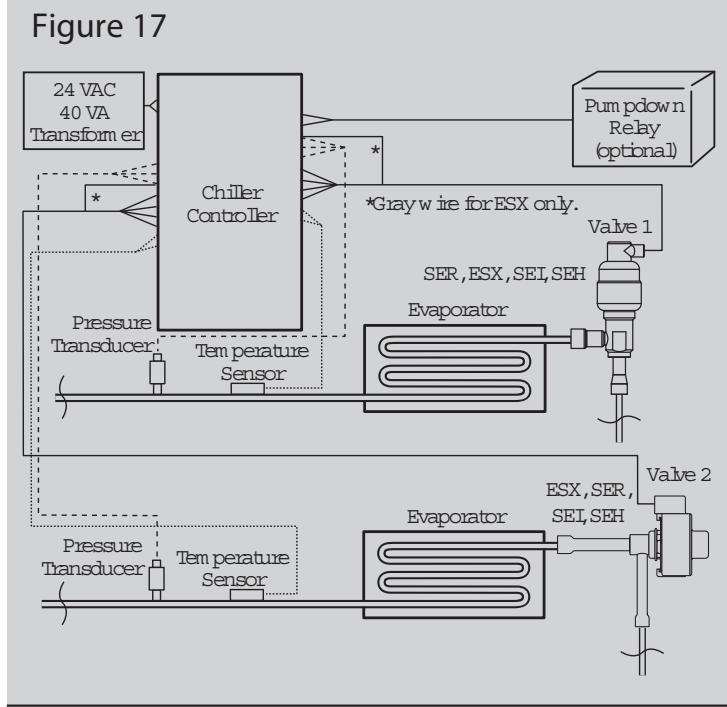
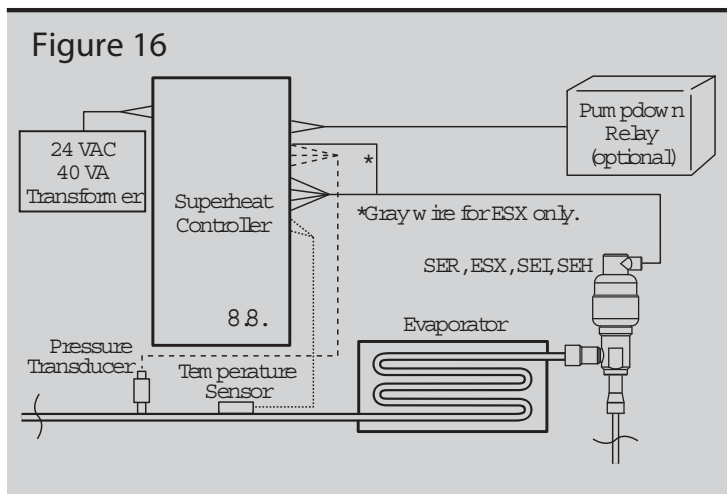

All Sporlan EEVs are precision flow controls and work in conjunction with sensors and a controller that are user specified. The valves can perform multiple functions to consolidate several controls and the associated piping, into one compact valve. These include, but are not limited to, superheat control, pressure control and limiting (e.g. MOP), temperature control, capacity control and liquid line shutoff.

AIR-CONDITIONING and REFRIGERATION SYSTEMS

Sporlan EEVs are most commonly used as expansion valves to control superheat in air-conditioners, and self-contained or supermarket refrigeration. They provide for precise flow control under every operating condition while eliminating the need for an upstream liquid solenoid shutoff valve in most applications. For air-conditioning, the valves provide extremely low off-cycle leakage and the capability to rapidly respond to changing loads for maximum efficiency and capability. See Figure 16.

MULTIPLE EVAPORATOR/VARIABLE CAPACITY SYSTEMS

Sporlan EEV's are ideal for multiple evaporator systems when a valve is installed on the each evaporator. Individual evaporator control is possible while also permitting some or all of the evaporators to be turned off depending on load or zone requirements. Partial evaporator loading is also possible. When used with multiple capacity compressors, the valves can maximize efficiency while matching refrigerant flow rate to changing compressor capacity. Refer to Figure 17.

SPLIT HEATPUMP SYSTEMS

Sporlan EEVs, installed with external check valves, can be used on either or both of the heat exchangers on heat pumps to provide maximum capacity and efficiency. Optimum control of superheat can be made based upon measurements anywhere in the system all the way up the compressor, not just at the heat exchanger (evaporator or condenser). The valves also provide extremely low off-cycle leakage, and the ability to rapidly respond to changing loads for maximum efficiency and capacity. Refer to Figure 18.

ICE MACHINE SYSTEMS

Ice machines utilizing the Sporlan EEVs benefit greatly from the rapid pulldown, and ability to modulate low operating superheats. Based on sensor and controller configuraton, the ESX can maximize ice capacity by reducing machine cycle time. The valves can be

used over a greater range of capacities than conventional TEVs thus maximizing pulldown capacity after harvests. Refer to Figure 19.

CONSTANT EVAPORATOR PRESSURE

Sporlan EEV valves can be used to manage refrigerant flow in applications requiring close control of evaporator pressure at varying loads. With proper control, the valves can control the temperature of process fluids, chillers, ice cream, and "slushy" type applications. With an operator interface, the valves can increase the versatility of equipment by allowing the end user to set the required temperature control; equipment no longer has to be dedicated to just one preset pressure or temperature setting. Refer to Figure 20.

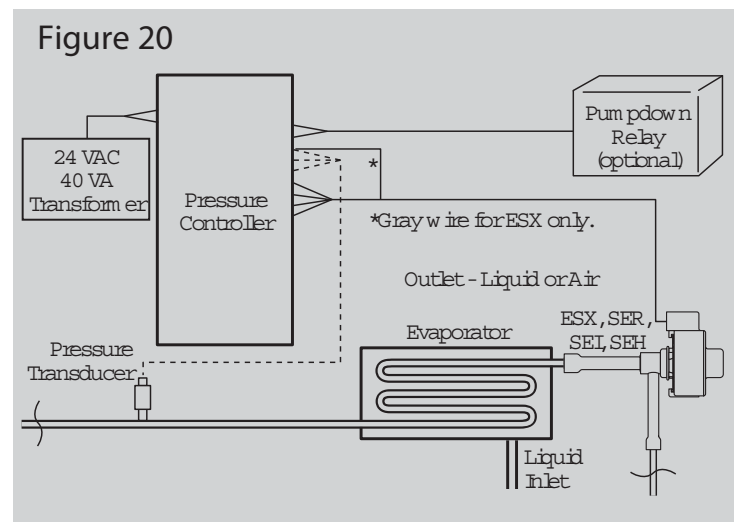

CONTROL OF ELECTRIC EVAPORATOR PRESSURE REGULATORS - EEPRs

Traditional forms of temperature control involve thermostats. Thermostats generally stop cooling when the temperature setpoint is reached, and start cooling when the temperature rises a certain amount above setpoint. This difference is called "deadband", and while modern thermostats may control to a 2-3° deadband, some temperature swing is inevitable.

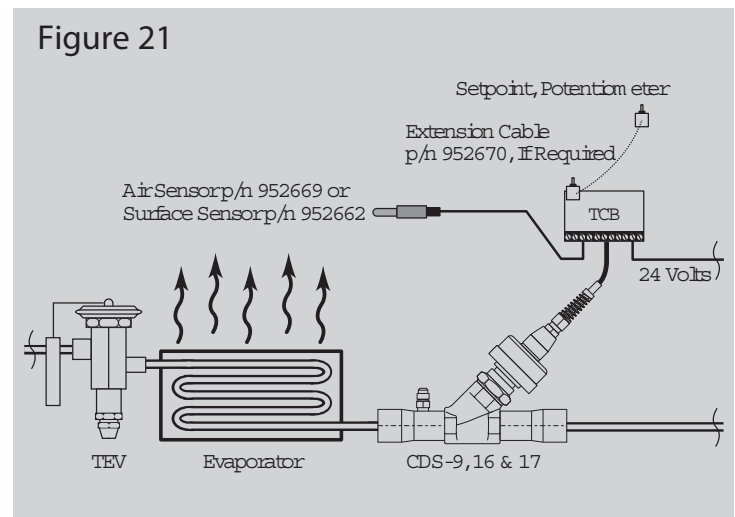

Direct acting or pilot operated mechanical evaporator control valves are simple to apply, and in many cases, very effective. However, both operate with a gradient – the valves must experience a pressure drop to open fully. In addition, mechanical EPRs are set by an adjusting screw. If the desired pressure and temperature change, the valves must be mechanically reset.

EEPRs are motor driven in response to a sensor. Because the sensors are very accurate and quick acting, EEPRs are not subject to gradient or large deadbands. Case temperature setpoint changes can be made electronically, without needing physical access to the valve. EEPRs can be driven shut for defrost and driven fully open after defrost to allow extremely rapid pulldown.

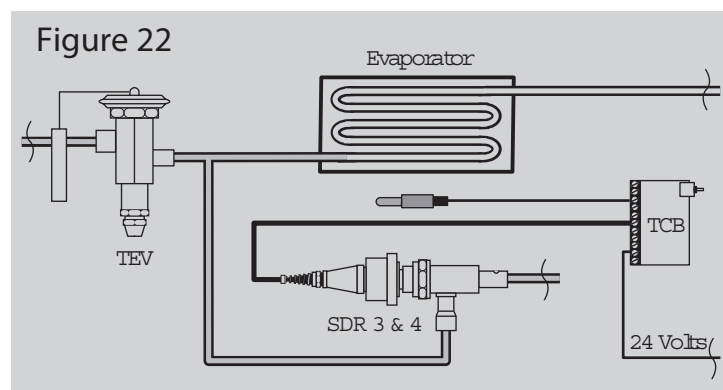

A complete electronic temperature control system can be field installed by using a Sporlan EEPR, TCB Temperature Control Board and temperature sensor. Request Bulletins 100-40 and 100-50-1. See capacity tables on page 15.

CONTROL OF ELECTRIC DISCHARGE GAS BYPASS VALVES - EDBVs

Mechanical, pressure operated, discharge gas bypass valves require a gradient, or change in pressure to operate. This may result in temperature swings of up to 10°F in setpoint. Greater accuracy can be obtained electronically.

Since all Sporlan step motors are qualified for use with hot gas, direct electronic temperature control of discharge gas bypass systems is now simple and economical. A Sporlan TCB, Temperature Control Board, and temperature sensor can be applied with any Sporlan EDBV. Request Bulletin 100-60 for more information.

HEAT RECLAIM APPLICATIONS

Heat reclaim involves diverting hot gas, rejected by a refrigeration or air conditioning system, into a secondary condenser for heating water or air. Any of the EDBV valves offered above can be used in this application,

but Sporlan is the first to offer purpose built electric heat reclaim valves. Any of the valves may be used with the TCB Temperature Control Board and temperature sensor.

TEMPERATURE CONTROL and INTERFACE BOARD

TCB

The Sporlan TCB was developed to allow the control of most Sporlan electric valves with the use of a generic PID or similar controller, or, with the addition of a Sporlan sensor, to perform as a stand alone temperature controller. In addition to the 0 to 10 volt DC or 4 to 20 milliamp signal usual from PID controllers, the TCB can be configured to modulate a valve in response to a TTL (5 volt) signal, or a 120 volt AC pulse of three to thirty seconds duration.

The TCB is designed to work with Sporlan SEI/SEH Electric Expansion Valves, CDS Electric Suction Control Valves, and SDR Electric Discharge Gas Bypass valves of any capacity. Pin jumpers on the face of the board permit changes in board control parameters to suit particular applications. The TCB is not suitable as a stand alone controller for EEVs because they do not control superheat.

The board was designed for easy standoff mounting in electrical panels, and has screw terminal wiring connections. The unit measures only 3.5" x 4.0" (90mm x 102mm), is economical and requires only 24 volts AC at 40 VA for both board and valve power. Operating ambient and storage temperature is -10°F to 160°F (-23°C to 71°C).

IB SERIES

The IB Series interface is a more economical alternative to the TCB. The IB is limited to accepting either a 0 to 10 volt DC signal or 4 to 20 milliamp signal. The IB must be ordered for specific valves. See the table at the bottom of page 15. The IB Series includes mounting kits.

TROUBLE SHOOTING and FAILURE MODES TROUBLESHOOTING

Electric valves respond only to the signal supplied by their controllers. Step motor valves will maintain their position, whether voltage is removed intentionally, or due to controller, power or wiring failure. In those applications where system damage may result from valves failing in an open position, a liquid line solenoid should be placed before the valve. Testing has shown that under most operating conditions

EEVs modulate at about 10% of full open. EEV or controller failures would most likely not lead to floodback, except immediately after defrost. Battery backup or Uninterruptable Power Supplies (UPS) can be designed for step motor applications, but reliability testing indicates that this would be an unnecessary expense.

Most modern controllers used with electric valves have built-in diagnostic capabilities. When a failure is experienced in the valve/controller system, the first step is to define the failure as controller related or valve related. The manufacturer should be consulted for specific trouble shooting information on the controller.

SMA-12

A simple resistance check can be made of the motor windings, however, actual winding failures are rare. Instead, all Sporlan electric valves can be tested with an optional hand held device, the SMA-12. The SMA-12 is a step motor actuator that operates all 12 volt DC, bipolar, and 4 phase unipolar step motor valves. The step rate can be selected at 1, 50, 100, or 200 steps-per-second. At the one step-per-second

rate the SMA-12 will test the continuity of the valve wiring and motor. The SMA-12 can also be used to manually open, position, or shut the valve during controller failure or replacement.

CONTAMINANT RELATED FAILURES

Contaminants remain the largest cause of component failures in refrigeration and air conditioning systems. In some instances, electric valves may be more tolerant to foreign material simply because they can be driven to a full open position to purge particulates. However, a high quality, solid core filter drier, like the Sporlan Catch-All® should be used in all systems having electric valves. Catch-All® Filter-Driers are proven to remove foreign materials as well as acid and oil breakdown material. Acid removal is important in all systems. In systems using step motors the reliability and life of the motor is extended when acid levels remain low. If contaminants are suspected the valves may be driven fully open to purge the foreign material. Most Sporlan electric step motor valves may be taken apart for cleaning and inspection, after the refrigerant is removed from the valve.

NOMENCLATURE AND CAPACITY INFORMATION

ELECTRIC EXPANSION VALVES					
MODEL	CONNECTIONS - ODF INLET - OUTLET	STYLE	MAX CAP TONS @ 125 ΔP R-22 @ 20°F	MAX CAP kW @ 8 BAR ΔP R-22 @ -10°F	NOMINAL STEPS
ESX-14	5/16, 3/18 - 5/16, 3/8, 1/2	ANGLE	1	3.5	500
ESX-18	5/16, 3/18 - 5/16, 3/8, 1/2	ANGLE	3	10.5	500
ESX-24	5/16, 3/18 - 5/16, 3/8, 1/2	ANGLE	5	17.5	500
SER-1.5	3/18, 1/2 - 1/2, 5/8	ANGLE	1.6	5.5	1596
SER-6	3/18, 1/2 - 1/2, 5/8	ANGLE	6.5	21.9	1596
SER-11	3/18, 1/2 - 1/2, 5/8	ANGLE	12.0	40.2	1596
SER-20	3/18, 1/2 - 1/2, 5/8	ANGLE	21.8	73.1	1596
SEI-30	1/2, 5/8, 7/8, 1-1/8 - 5/8, 7/8, 1-1/8, 1-3/8	ANGLE	38.1	128.0	3193
SEI-50	7/8, 1-1/8 - 1-1/8, 1-3/8, 1-5/8	STRAIGHTTHROUGH	54.3	183.0	6286
SEH-100	1-1/8 - 1-5/8	STRAIGHTTHROUGH	109.0	365.0	6386
SEH-175	1-1/8 - 2-1/8	STRAIGHTTHROUGH	190.0	638.0	6386

SER	-	1.5	3/8 X 1/2 ODF	-	10	-	S
VALVE TYPE		SIZE	CONNECTIONS		CABLE LENGTH - FEET		STRIPPED and TINNED CABLE ENDS

ELECTRIC EVAPORATOR PRESSURE REGULATORS					
MODEL	CONNECTIONS INCHES	STYLE	MAX CAP TONS @ 2 ΔP R-22 @ 20°F	MAX CAP kW @ 14 BAR ΔP R-22 @ -7°C	NOMINAL STEPS
CDS-9	5/8, 7/8 - 1-1/8 ODF	STRAIGHTTHROUGH	5.0/7.7	17.5/27	3193/6386
CDS-16	1-3/8 ODF	ANGLE	12.8	45	6386
CDS-17	1-3/8, 1-5/8 ODF	STRAIGHT	14.3	50	6386

CDS-T	-	16	1-3/8 ODF	ANGLE	-	10	-	S
CONTROLS DISCHARGE STEP with PRESSURE TAP		SIZE	CONNECTIONS	STYLE		CABLE LENGTH - FEET		STRIPPED and TINNED CABLE ENDS

ELECTRIC DISCHARGE GAS BYPASS VALVES					
MODEL	CONNECTIONS INCHES	STYLE	MAX CAP TONS @ 100° F COND R-22 @ 26°F EVAP	MAX CAP kW @ 38°C R-22 @ -3°C EVAP	NOMINAL STEPS
SDR-3	3/8, 1/2, 5/8 ODF	ANGLE	5.0	17.5	3193
SDR-3X	3/8, 1/2, 5/8 ODF	ANGLE	12.7	44.5	3193
SDR-4	7/8, 1-1/8 ODF	STRAIGHTTHROUGH	25.0	87.5	6386

SDR	-	3	1/2 ODF	-	10	-	S
STEP DISCHARGE REGULATOR		SIZE	CONNECTIONS		CABLE LENGTH - FEET		STRIPPED and TINNED CABLE ENDS

DIAGNOSTIC TOOL		
MODEL	STEP RATE	POWER REQUIREMENTS
SMA-12	1, 50, 100, 200 SELECTABLE	2-9 VOLT ALKALINE BATTERIES

SINGLE POINT TEMPERATURE CONTROLLER & INTERFACE BOARDS				
MODEL	EXTERN SIGNAL	* SENSORS -40°F - 210° F RANGE	POWER REQUIREMENT	USED WITH
TCBP/N952660	4-20 milliamp 1-10 volt DC 5 volt TTL 120 volt AC PWM	N/A	24 VAC @ 40 VA	CDS Series SDR Series y-1177-1
TCB with Potentiometer P/N 952664	1-10 volt DC 5 volt TTL 120 VOLT AC PWM Temperature Control	Air Sensor - P/N 952669 Surface Sensor with Mounting Clip - P/N 952662 Well Sensor - P/N 952795		
IB1 P/N 952955	4-20 milliamp 0-10 volt DC	N/A	24 VAC @ 20 VA	SER**
IB3 P/N 952956				SDR-3, SEI-30**
IB6 P/N 952957				**All other valves

* TCB setpoint readout available in °F only.

** Interface boards may be used with EEVs but, the external signal must represent superheat to prevent compressor damage.

GLOSSARY

A to D - Analog to Digital conversion. Most real world conditions are analog, but most computers need digital signals. This device converts the signals from analog (varying) to digital (on/off).

ALGORITHM - The set of instructions that the microcontroller uses to perform a specific task. Example-controlling superheat by the two temperature method.

AMP/AMPERE - A unit of measure of electrical flow. Similar to gallons per minute or pounds per minute in other fluids.

ANALOG SIGNAL - Type of information flow that varies in magnitude, voltage, current, etc. Most real world processes like temperature, pressure, etc. are analog.

ANALOG VALVE - A electronically driven valve that modulates by a varying voltage or current signal. Sporlan CDA and EI valves were of this type.

BIPOLAR - A type of step motor in which the current flow changes direction for each step. In all Sporlan valves, except the ESX, the black lead is positive for the first step and negative for the second step, while the white lead is negative for the first step and positive for the second step.

BURNED-IN - One of two processes. The first is placing a unchangeable program into a microprocessor, the second is a quality test where the completed device is powered and tested for a time, usually at an elevated temperature.

CHIP - Informal way of referring to an integrated circuit. Integrated circuits are printed on a "chip" of silicon.

CHOPPER DRIVE - A step motor drive in which the voltage begins high and is reduced during the power sequence.

CODE - The language the computer actually uses to perform a task. Example: movw, f oxo2B.

CURRENT - The flow of electricity.

D to A - Refers to Digital to Analog conversion. Used to convert the computers digital signal (a number) to a varying signal (loudness).

DDC - Direct Digital Control. What most modern electronically controlled building or energy management systems are called.

DIGITAL - Type of information flow that is on or off, or binary. Opposite of analog.

FLOW CHART - The plain language description of how an algorithm works. Example: When the superheat is 10 degrees too high, open the valve 200 steps.

GATEWAY - A software program that must be used to allow one computer system to communicate with another computer system.

HARDWARE - The parts of a computer or controller. For example, the printed circuit board, the electronic components and connectors.

HEAT MOTOR - A motive power for valves that consists of a bellows filled with oil or other fluid. A heater is immersed in the fluid, and when supplied with power, the heater heats and expands the fluid forcing the valve to close.

L/R DRIVE - Inductance/resistance drive for step motors. Basically a fixed voltage is turned on and off to supply power to the valves.

MICROCONTROLLER - A small computer built onto a "chip" of silicon. It needs few additional parts to perform sophisticated calculation. Usually purchased with the program or algorithm already installed or burned in.

MICROPROCESSOR - Usually the part of the computer or microcontroller that runs and keeps track of the program.

MILLIAMP - Short for Milliampere, abbreviated ma. One thousandth of an ampere of current. See: AMP/Ampere.

PLC - Programmable Logic Controller. Like a microcontroller but usually programmed by the user.

PRESSURE TRANSDUCER - A device that senses a pressure and converts it to an electrical signal, usually voltage.

PROGRAM - A set of instructions given to a computer.

PWM - Pulse Width Modulation. A form of control in which a valve is open for a percentage of time proportional to load, e.g. for 50% load the valve will be open 50% of time and closed for 50% of the time.

PULSE VALVE - A solenoid-like valve that opens fully and closes fully each time a signal is received. Controlled by Pulse Width Modulation. See: PWM.

SENSOR - A device that senses something in the real world and translates it to information the computer can use. See: thermistor, pressure transducer.

SOFTWARE - A general term for programs.

STEP/STEPPER MOTOR - A motor that rotates a set number of degrees of arc for each electrical impulse it receives. Referred to by the degrees of rotation and diameter. Sporlan uses a 3.6°, 42 millimeter motor.

THERMISTOR - A device that changes its electrical resistance with changes in temperature. Used as a temperature sensor.

μC - Symbol for microcontroller.

UNIPOLAR - A type of step motor where the current always flows in the same direction. In the ESX valve the gray lead is always positive and each of the other leads is grounded in turn.

μP - Symbol for microprocessor.

VOLT - A unit of electrical pressure. Causes electricity to flow. Similar to PSI for other fluids.



Parker Hannifin Ltd
Refrigeration and Air Conditioning Europe
Cortonwood Drive, Brampton
South Yorkshire S73 0UF
United Kingdom
phone +44 (0) 1226 273400
fax +44 (0) 1226 273401
www.parker.com/race

RACE Catalogue 100-9 UK - 06/2010 - Zalsman