

Kelvion



Coolers

Searle KEC Air cooler

HIGH EFFICIENCY, HIGH PERFORMANCE



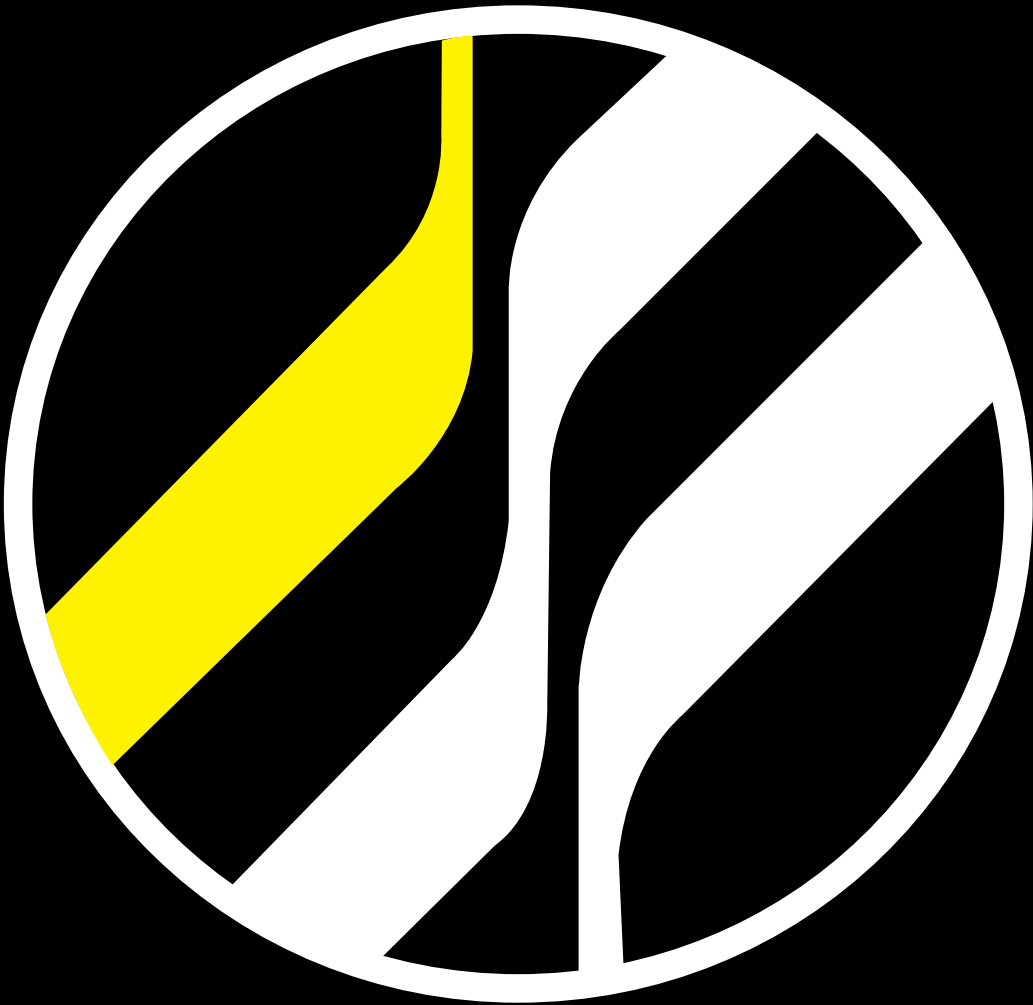

WE ARE KELVION – THE NEW BRAND IN HEAT EXCHANGE

GEA Heat Exchangers has changed: another new standalone company has been created out of the former Heat Exchanger Division of the GEA Group AG. The name Kelvion is new, but we continue as global experts in heat exchange. As always, we remain committed to earning your trust.

You'll still recognise us. We continue to develop our products, manufacture them with precision and distribute globally. We continue to offer one of the world's largest heat exchanger product portfolios: Plate heat exchangers, shell & tube heat exchangers, finned tube heat exchangers, modular cooling towers and refrigeration heat exchangers for a wide range of applications.

We operate in global markets for power generation, oil and gas, chemistry, marine applications, climate and environment, and food and beverages. From us, you can expect products with outstanding levels of efficiency, safety, and sustainability. More importantly, we care about your business, like close, trusted partners.

Customers rely on us to understand their needs, boost their performance, and deliver products that always get the job done. We compete for the toughest deals, in the harshest environments. But we're not too big to care. We're Kelvion – ready to take on the challenges of heat exchange. www.kelvion.com

Experts in Heat Exchange.

Searle KEC air cooler

HIGH EFFICIENCY HIGH PERFORMANCE



The Searle KEC cooler is part of the next generation of Unit Coolers by Kelvion, with market leading performance, noise levels and energy efficiency. Using EC fan set technology as standard across the range, the power input for the KEC cooler is typically in excess of 50% lower than that of equivalent AC motor technology. The KEC coolers cover a capacity range from 1.2 - 10.5kW at Eurovent conditions and are the cooler of choice for a wide range of cold room applications. The KEC has a modern aesthetic design and is easy to install and maintain without compromise on reliability and rigidity. A range of refrigerants can be selected using Kelvion selection software. The KEC defrost system has been designed with efficiency and application variability in mind. The KEC utilises more heater elements than previous design

variants, operating at a lower temperature to achieve a more even heat flux.

- Suitable for medium and low temperature cold room applications
- Unit is ceiling mounted.
- CO₂ options for direct expansion and pumped applications
- 1, 2 or 3 fan configurations



Features

- Comprises of 10 models
- Available in 4mm, 6mm and 8mm fin spacings
- 1,2 or 3 fan configurations
- Eurovent certified

Searle KEC air cooler

KEC RANGE PRODUCT PROFILE

1 CASEWORK

The casework is formed from galvanized steel and finished with oven cured white epoxy powder paint (RAL 9010). The construction is both rigid and versatile, giving the installer and users flexibility and confidence in service life. Connections and junction boxes for the unit are easily accessible through removable side panels which are fixed in place using easy-alignment keyhole slots.

The drain tray is fabricated from galvanised painted steel and is supplied loose, once the unit is installed on site the drain connection can be fitted to the tray and the tray fitted to the unit in its operating position.

2 FANS

The Searle KEC cooler from Kelvion, utilises EC fan sets as standard. The EC motors can accept 196-253V 1Ph at 50/60Hz with built in thermal protection.

- Fan diameter: 300mm
- Number of Blades: 5
- Guard: Metal Wire (Black)
- Fan Rotation: Clockwise when facing air stream
- Motor Rating: IP54
- Aluminium orifice
- Temperature Range :40°C to +40°C

3 COIL

The coil used in the KEC range balances surface and defrost efficiency and is the result of extensive R&D. The coil is assembled in one block, is available as either 4 or 6 rows deep and uses using aluminium fins as standard. The coil has inner groove tubes on 43mm equilateral centres mechanically bonded to the fin.

- Manufactured from ½" Tube
- Tube Pitch Across Airflow: 43mm
- Tube Pitch In Direction of Airflow: 37.2mm
- Fin Spacing (s): 4mm, 6mm and 8mm
- Fin Enhancements: Light Ripple
- Formed heater holes

CO₂ OPTION

Kelvion has delivered a new generation of environmentally friendly CO₂ unit coolers, with a capacity range of 0.9 - 9.9kW. Using the same robust case construction as the standard KEC range and utilising the same high efficiency fan sets, the difference lies in the coil itself. To develop this coil technology specifically for a range of CO₂ applications, extensive testing and analysis was essential to ensure they deliver the performance required across a wide range of potential operating conditions. All units are tested to 1.43 x maximum operating pressure before delivery, and 3 standard operating pressure are offered as standard:

- 57 Bar = KEC-LP
- 80 Bar = KEC - MP
- 90 Bar = KEC-HP.

KEC Refrigerant data

Refrigeration	R404A	R134a	R507A	R407A/F	R407C
Capacity factor (dew point, DT1)	1.00	0.91	0.97	1.24*	1.26*
Refrigerant charge density (kg/dm ³)	0.312	0.338	0.313	0.332	0.332

* Capacity factors for refrigerants with high glide apply only at the nominal rating condition.

Refrigerant charge densities are based on 25% of the internal volume being liquid.

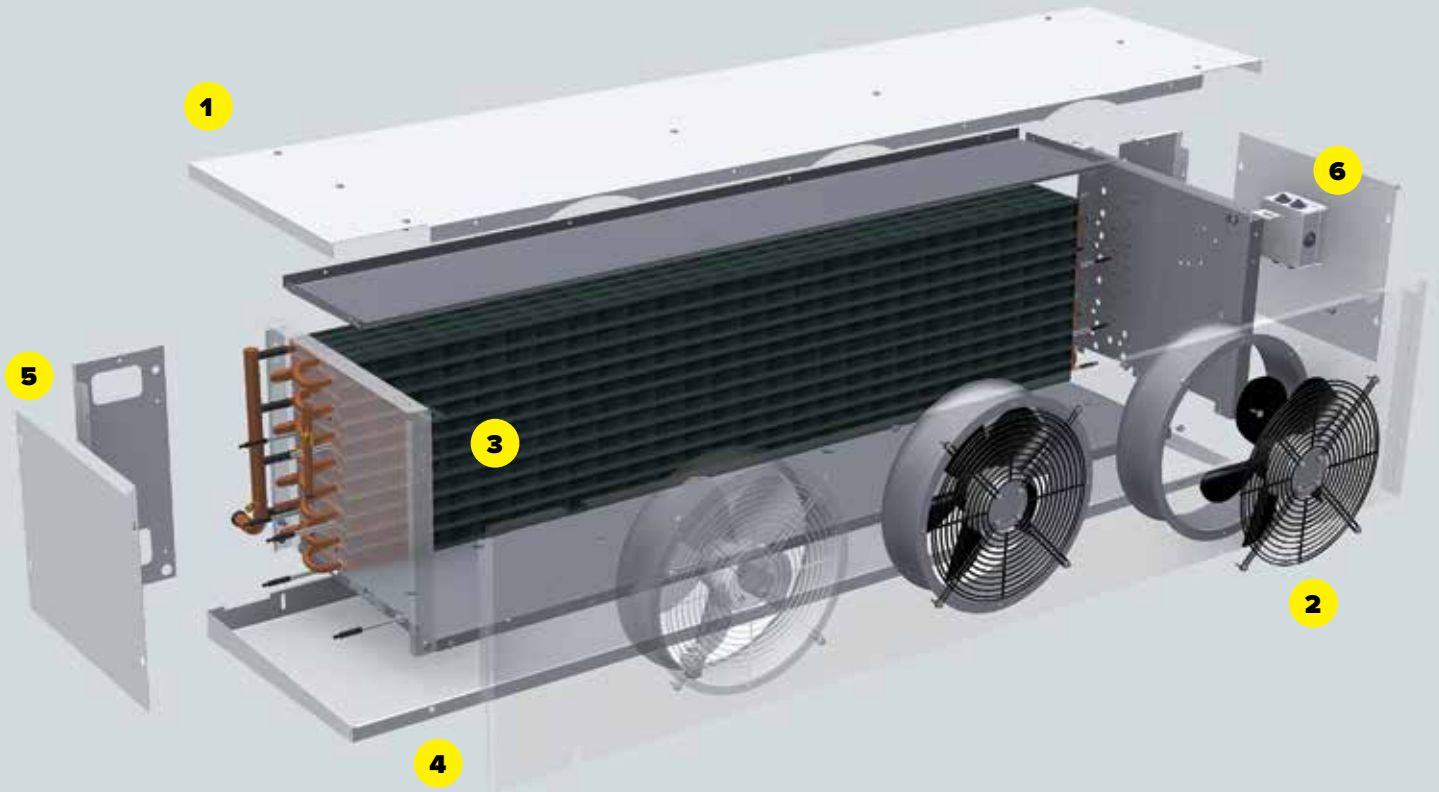

- 4** Drain Tray
- 5** End plates
- 6** Junction box



Nomenclature

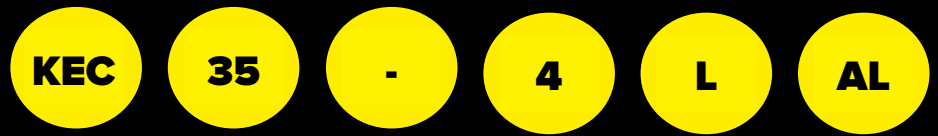

Range: KEC, KEC-LP, KEC-MP, KEC-LX, KEC-MX, KEC-HX

Model: 10, 15, 20, 25, 30, 35, 40, 45, 55, 70

Fin Spacing: 4mm, 6mm, 8mm

(Type for CO₂): X = direct expansion, L = 57 bar, M = 80 bar, H = 90 bar

Defrost: No defrost, L = Standard Electric defrost, HGD = Hot Gas Coil & tray, HGE = Hot Gas Coil & Electric tray. Each gas defrost option is followed with either an A/ B / C /D, to designate the circuiting option.

Fin Material: AL = Aluminium

Capacities: R404A: 1.2 kW - 10.5 kW CO₂: 0.9 kW - 9.9kW

KEC Selection Data

Fin spacing	Model	Capacity 8K R744 *	Motor details 230V - 1ph - 50Hz					Fan data			Connections		Internal volume	Surface area	Ref Charge	Weight
			No. of fans	Power input	FLC per fan	SC per fan	Speed	Air Volume	Air throw ***	Noise level @ 3m **	Inlet	Outlet				
		kW	W	amps	amps	RPM	m ³ /s	m	dB(A)			dm ³				
4mm	KEC10-4	1.65	1	33	0.35	0.50	1370	0.28	16.0	44	1/2"	1/2"	1.4	8.5	0.5	27
	KEC15-4	2.01	1	33	0.35	0.50	1370	0.28	16.0	44	1/2"	1/2"	1.9	10.0	0.6	28
	KEC20-4	2.35	1	33	0.35	0.50	1370	0.29	16.0	44	1/2"	5/8"	2.5	13.7	0.8	33
	KEC25-4	3.00	1	77	0.70	1.00	1750	0.42	22.0	52	1/2"	5/8"	2.5	13.7	0.8	33
	KEC30-4	3.73	1	77	0.70	1.00	1750	0.40	22.0	52	1/2"	7/8"	3.8	20.5	1.2	35
	KEC35-4	4.57	2	66	0.35	0.50	1370	0.58	16.0	47	1/2"	7/8"	4.3	24.9	1.4	47
	KEC40-4	5.84	2	154	0.70	1.00	1750	0.83	22.0	55	1/2"	7/8"	4.3	24.9	1.4	47
	KEC45-4	6.99	2	154	0.70	1.00	1750	0.81	22.0	55	1/2"	7/8"	6.5	37.4	2.1	53
	KEC55-4	8.79	3	231	0.70	1.00	1750	1.25	22.0	57	1/2"	7/8"	6.3	37.4	2.0	67
KEC70-4	10.51	3	231	0.70	1.00	1750	1.21	22.0	57	5/8"	7/8"	9.4	56.0	3.0	74	
6mm	KEC10-6	1.34	1	33	0.35	0.50	1370	0.31	16.0	44	1/2"	1/2"	1.4	5.8	0.5	27
	KEC15-6	1.72	1	33	0.35	0.50	1370	0.31	16.0	44	1/2"	1/2"	1.9	6.8	0.6	28
	KEC20-6	1.99	1	33	0.35	0.50	1370	0.32	16.0	44	1/2"	5/8"	2.5	9.4	0.8	33
	KEC25-6	2.38	1	77	0.70	1.00	1750	0.43	22.0	52	1/2"	5/8"	2.5	9.4	0.8	33
	KEC30-6	3.16	1	77	0.70	1.00	1750	0.42	22.0	52	1/2"	7/8"	3.8	14.1	1.2	35
	KEC35-6	3.85	2	66	0.35	0.50	1370	0.63	16.0	47	1/2"	7/8"	4.3	17.0	1.4	47
	KEC40-6	4.63	2	154	0.70	1.00	1750	0.85	22.0	55	1/2"	7/8"	4.3	17.0	1.4	47
	KEC45-6	5.97	2	154	0.70	1.00	1750	0.83	22.0	55	1/2"	7/8"	6.5	25.6	2.1	53
	KEC55-6	7.00	3	231	0.70	1.00	1750	1.28	22.0	57	1/2"	7/8"	6.3	25.6	2.0	67
KEC70-6	8.98	3	231	0.70	1.00	1750	1.25	22.0	57	5/8"	7/8"	9.4	38.3	3.0	74	
8mm	KEC10-8	1.17	1	33	0.35	0.50	1370	0.32	16.0	44	1/2"	1/2"	1.4	4.4	0.5	27
	KEC15-8	1.52	1	33	0.35	0.50	1370	0.32	16.0	44	1/2"	1/2"	1.9	5.2	0.6	28
	KEC20-8	1.74	1	33	0.35	0.50	1370	0.33	16.0	44	1/2"	5/8"	2.5	7.2	0.8	33
	KEC25-8	2.06	1	77	0.70	1.00	1750	0.44	22.0	52	1/2"	5/8"	2.5	7.2	0.8	33
	KEC30-8	2.75	1	77	0.70	1.00	1750	0.43	22.0	52	1/2"	7/8"	3.8	10.8	1.2	35
	KEC35-8	3.30	2	66	0.35	0.50	1370	0.65	16.0	47	1/2"	7/8"	4.3	13.1	1.4	47
	KEC40-8	3.98	2	154	0.70	1.00	1750	0.86	22.0	55	1/2"	7/8"	4.3	13.1	1.4	47
	KEC45-8	5.31	2	154	0.70	1.00	1750	0.86	22.0	55	1/2"	7/8"	6.5	19.7	2.1	53
	KEC55-8	6.01	3	231	0.70	1.00	1750	1.31	22.0	57	1/2"	7/8"	6.3	19.7	2.0	67
KEC70-8	7.97	3	231	0.70	1.00	1750	1.29	22.0	57	5/8"	7/8"	9.4	29.5	3.0	74	

Notes: Rating conditions - The duties shown in this brochure are at EN 328 Standard Condition 2 (-8°C saturated suction temperature, 0°C air entering). To select at your application conditions please use the Kelvion Searle Selection Software or contact your local sales representative for more information.

- * DT1 is the difference between the entering air temperature and the saturated suction temperature at the outlet of the cooler.
- ** Noise levels are based on free field conditions at a distance of 3m. Actual noise levels will depend upon cold store construction, store loading and the number of coolers installed.
- *** Terminal air velocity 0.25m/s, free air conditions at 10°C. Air throw cannot be considered an absolute value because many factors have a substantial effect on the distance achieved.

Electric defrost data

Model	Electric Defrost		
	230V-1PH-50/60Hz		Standard
	Coil	Pan	Total
	kW	kW	kW
KEC10-*	0.68	0.34	1.02
KEC15-*	0.68	0.34	1.02
KEC20-*	0.92	0.46	1.38
KEC25-*	0.92	0.46	1.38
KEC25-*	0.92	0.46	1.38
KEC35-*	1.6	0.8	2.4
KEC40-*	1.6	0.8	2.4
KEC45-*	1.6	0.8	2.4
KEC55-*	2.4	1.2	3.6
KEC70-*	2.4	1.2	3.6

CO₂ KEC Direct expansion

LX (57bar), MX (80 bar), HX (90 bar)

Fin spacing	Model	Capacity 8K R744 *	Motor details 230V - 1ph - 50Hz					Fan data			Connections		Internal volume	Surface area	Ref Charge	Weight
			No. of fans	Power input	FLC per fan	SC per fan	Speed	Air Volume	Air throw ***	Noise level @ 3m **	Inlet	Outlet				
		kW	W	amps	amps	RPM	m ³ /s	m	dB(A)			dm ³				
4mm	KEC-*X10-4	1.40	1	33	0.35	0.50	1370	0.28	16	44	1/2"	5/8"	2.0	7.5	0.9	29
	KEC-*X15-4	1.70	1	33	0.35	0.50	1370	0.28	16	44	1/2"	5/8"	2.0	10.0	0.9	30
	KEC-*X20-4	2.00	1	33	0.35	0.50	1370	0.29	16	44	1/2"	5/8"	3.0	13.7	1.3	37
	KEC-*X25-4	2.50	1	77	0.70	1.00	1750	0.42	22	52	1/2"	5/8"	3.0	13.7	1.3	37
	KEC-*X30-4	3.10	1	77	0.70	1.00	1750	0.40	22	52	1/2"	5/8"	4.0	20.5	1.7	41
	KEC-*X35-4	4.00	2	66	0.35	0.50	1370	0.58	16	47	1/2"	5/8"	5.0	24.9	2.2	54
	KEC-*X40-4	5.20	2	154	0.70	1.00	1750	0.83	22	55	1/2"	5/8"	5.0	24.9	2.2	54
	KEC-*X45-4	6.90	2	154	0.70	1.00	1750	0.81	22	55	1/2"	5/8"	7.0	37.3	3.0	62
	KEC-*X55-4	8.60	3	231	0.70	1.00	1750	1.25	22	57	1/2"	5/8"	6.0	37.3	2.6	76
KEC-*X70-4	9.90	3	231	0.70	1.00	1750	1.21	22	57	1/2"	5/8"	9.0	56.0	3.9	89	
6mm	KEC-*X10-6	1.20	1	33	0.35	0.50	1370	0.31	16	44	1/2"	5/8"	2.0	5.1	0.9	29
	KEC-*X15-6	1.50	1	33	0.35	0.50	1370	0.31	16	44	1/2"	5/8"	2.0	6.8	0.9	30
	KEC-*X20-6	1.80	1	33	0.35	0.50	1370	0.32	16	44	1/2"	5/8"	3.0	9.4	1.3	37
	KEC-*X25-6	2.10	1	77	0.70	1.00	1750	0.43	22	52	1/2"	5/8"	3.0	9.4	1.3	37
	KEC-*X30-6	2.70	1	77	0.70	1.00	1750	0.42	22	52	1/2"	5/8"	4.0	14.0	1.7	41
	KEC-*X35-6	3.40	2	66	0.35	0.50	1370	0.63	16	47	1/2"	5/8"	5.0	17.0	2.2	54
	KEC-*X40-6	4.20	2	154	0.70	1.00	1750	0.85	22	55	1/2"	5/8"	5.0	17.0	2.2	54
	KEC-*X45-6	6.00	2	154	0.70	1.00	1750	0.83	22	55	1/2"	5/8"	7.0	25.5	3.0	62
	KEC-*X55-6	7.00	3	231	0.70	1.00	1750	1.28	22	57	1/2"	5/8"	6.0	25.5	2.6	76
KEC-*X70-6	8.40	3	231	0.70	1.00	1750	1.25	22	57	1/2"	5/8"	9.0	38.3	3.9	89	
8mm	KEC-*X10-8	0.90	1	33	0.35	0.50	1370	0.32	16	44	1/2"	5/8"	2.0	3.9	0.9	29
	KEC-*X15-8	1.30	1	33	0.35	0.50	1370	0.32	16	44	1/2"	5/8"	2.0	5.2	0.9	30
	KEC-*X20-8	1.60	1	33	0.35	0.50	1370	0.33	16	44	1/2"	5/8"	3.0	7.2	1.3	37
	KEC-*X25-8	1.80	1	77	0.70	1.00	1750	0.44	22	52	1/2"	5/8"	3.0	7.2	1.3	37
	KEC-*X30-8	2.40	1	77	0.70	1.00	1750	0.43	22	52	1/2"	5/8"	4.0	10.8	1.7	41
	KEC-*X35-8	3.00	2	66	0.35	0.50	1370	0.65	16	47	1/2"	5/8"	5.0	13.1	2.2	54
	KEC-*X40-8	3.60	2	154	0.70	1.00	1750	0.86	22	55	1/2"	5/8"	5.0	13.1	2.2	54
	KEC-*X45-8	5.20	2	154	0.70	1.00	1750	0.86	22	55	1/2"	5/8"	7.0	19.6	3.0	62
	KEC-*X55-8	6.10	3	231	0.70	1.00	1750	1.31	22	57	1/2"	5/8"	6.0	19.6	2.6	76
KEC-*X70-8	7.90	3	231	0.70	1.00	1750	1.29	22	57	1/2"	5/8"	9.0	29.4	3.9	89	

CO2 KEC Pumped

LP (57bar), MP (80 bar)

Fin spacing	Model	Capacity 8K R744 *	Motor details 230V - 1ph - 50Hz					Fan data			Connections		Internal volume	Surface area	Ref Charge	Weight
			No. of fans	Power input	FLC per fan	SC per fan	Speed	Air Volume	Air throw ***	Noise level @ 3 **	Inlet	Outlet				
		kW	W	amps	amps	RPM	m ³ /s	m	dB(A)			dm ³				
4mm	KEC-*P10-4	1.80	1	33	0.35	0.5	1370	0.28	16	44	5/8"	7/8"	2.0	7.5	1.2	29
	KEC-*P15-4	2.09	1	33	0.35	0.5	1370	0.28	16	44	5/8"	7/8"	2.0	10.0	1.2	30
	KEC-*P20-4	2.33	1	33	0.35	0.5	1370	0.29	16	44	5/8"	7/8"	3.0	13.7	1.8	37
	KEC-*P25-4	2.97	1	77	0.7	1	1750	0.42	22	52	5/8"	7/8"	3.0	13.7	1.8	37
	KEC-*P30-4	3.57	1	77	0.7	1	1750	0.40	22	52	5/8"	7/8"	4.0	20.5	2.4	41
	KEC-*P35-4	4.70	2	66	0.35	0.5	1370	0.58	16	47	5/8"	7/8"	5.0	24.9	3.0	54
	KEC-*P40-4	6.35	2	154	0.7	1	1750	0.83	22	55	5/8"	7/8"	5.0	24.9	3.0	54
	KEC-*P45-4	7.91	2	154	0.7	1	1750	0.81	22	55	5/8"	7/8"	7.0	37.3	4.2	62
	KEC-*P55-4	10.16	3	231	0.7	1	1750	1.25	22	57	5/8"	7/8"	6.0	37.3	3.6	76
KEC-*P70-4	11.36	3	231	0.7	1	1750	1.21	22	57	5/8"	7/8"	9.0	56.0	5.4	89	
6mm	KEC-*P10-6	1.55	1	33	0.35	0.5	1370	0.31	16	44	5/8"	7/8"	2.0	5.1	1.2	29
	KEC-*P15-6	1.85	1	33	0.35	0.5	1370	0.31	16	44	5/8"	7/8"	2.0	6.8	1.2	30
	KEC-*P20-6	2.10	1	33	0.35	0.5	1370	0.32	16	44	5/8"	7/8"	3.0	9.4	1.8	37
	KEC-*P25-6	2.49	1	77	0.7	1	1750	0.43	22	52	5/8"	7/8"	3.0	9.4	1.8	37
	KEC-*P30-6	3.11	1	77	0.7	1	1750	0.42	22	52	5/8"	7/8"	4.0	14.0	2.4	41
	KEC-*P35-6	4.00	2	66	0.35	0.5	1370	0.63	16	47	5/8"	7/8"	5.0	17.0	3.0	54
	KEC-*P40-6	5.12	2	154	0.7	1	1750	0.85	22	55	5/8"	7/8"	5.0	17.0	3.0	54
	KEC-*P45-6	6.88	2	154	0.7	1	1750	0.83	22	55	5/8"	7/8"	7.0	25.5	4.2	62
	KEC-*P55-6	8.27	3	231	0.7	1	1750	1.28	22	57	5/8"	7/8"	6.0	25.5	3.6	76
KEC-*P70-6	9.64	3	231	0.7	1	1750	1.25	22	57	5/8"	7/8"	9.0	38.3	5.4	89	
8mm	KEC-*P10-8	1.16	1	33	0.35	0.5	1370	0.32	16	44	5/8"	7/8"	2.0	3.9	1.2	29
	KEC-*P15-8	1.60	1	33	0.35	0.5	1370	0.32	16	44	5/8"	7/8"	2.0	5.2	1.2	30
	KEC-*P20-8	1.87	1	33	0.35	0.5	1370	0.33	16	44	5/8"	7/8"	3.0	7.2	1.8	37
	KEC-*P25-8	2.14	1	77	0.7	1	1750	0.44	22	52	5/8"	7/8"	3.0	7.2	1.8	37
	KEC-*P30-8	2.76	1	77	0.7	1	1750	0.43	22	52	5/8"	7/8"	4.0	10.8	2.4	41
	KEC-*P35-8	3.53	2	66	0.35	0.5	1370	0.65	16	47	5/8"	7/8"	5.0	13.1	3.0	54
	KEC-*P40-8	4.39	2	154	0.7	1	1750	0.86	22	55	5/8"	7/8"	5.0	13.1	3.0	54
	KEC-*P45-8	5.96	2	154	0.7	1	1750	0.86	22	55	5/8"	7/8"	7.0	19.6	4.2	62
	KEC-*P55-8	7.21	3	231	0.7	1	1750	1.31	22	57	5/8"	7/8"	6.0	19.6	3.6	76
KEC-*P70-8	9.06	3	231	0.7	1	1750	1.29	22	57	5/8"	7/8"	9.0	29.4	5.4	89	

Notes: Rating conditions - The duties shown in this brochure are at EN 328 Standard Condition 2 (-8°C saturated suction temperature, 0°C air entering). To select at your application conditions please use the Kelvion Searle Selection Software or contact your local sales representative for more information.

- * DT1 is the difference between the entering air temperature and the saturated suction temperature at the outlet of the cooler.
- ** Noise levels are based on free field conditions at a distance of 3m. Actual noise levels will depend upon cold store construction, store loading and the number of coolers installed.
- *** Terminal air velocity 0.25m/s, free air conditions at 10°C. Air throw cannot be considered an absolute value because many factors have a substantial effect on the distance achieved.

KEC - dimension drawings

KEC 10 - 15

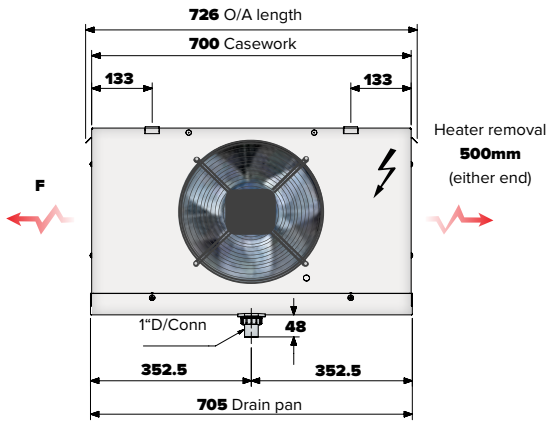

Hanging bracket for all KEC Models

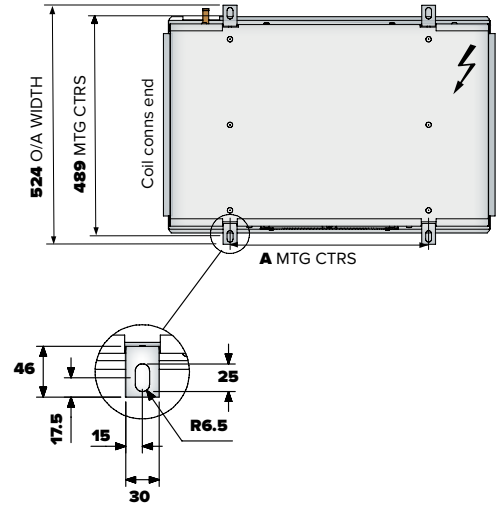

KEC 20 - 30

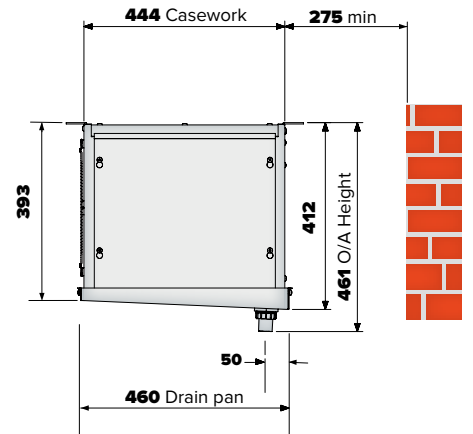
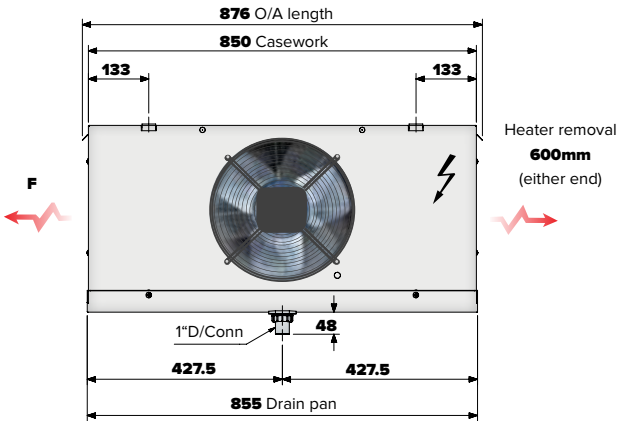

KEC 35 - 45

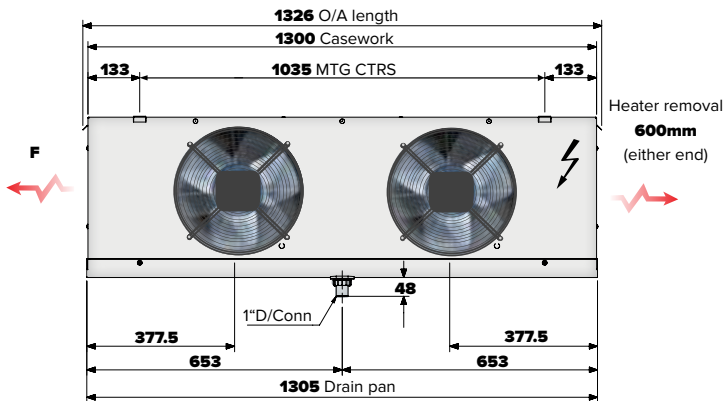

Model	Dim A
KEC10	435
KEC15	435
KEC20	585
KEC25	585
KEC30	585
KEC35	1035
KEC40	1035
KEC45	1035
KEC55	1535
KEC70	1535

KEC 55 - 70

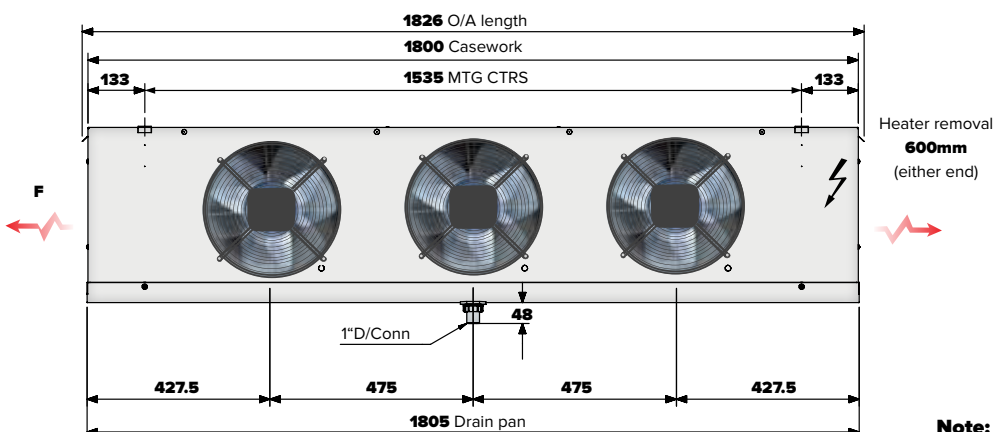

Note: All dimensions in mm, **F'** = Min heat Withdrawal

Kelvion

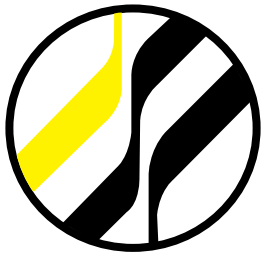

Terms and Conditions of Sales. Searle A trading division of Kelvion Ltd.

1. GENERAL

Special attention is drawn to the Warranty.

The following words shall have the following meanings in these Conditions.

- (a) The "Buyer" is the person firm or company with whom the Seller has entered into the Contract.
- (b) The "Conditions" shall mean the terms and conditions set out below.
- (c) The "Contract" is the agreement (as referred to in clause 2) to supply particular Goods.
- (d) The "Goods" are the goods sold by the Seller to the Buyer.
- (e) The "Seller" is Kelvion Ltd
- (f) "Warranty" shall mean the warranty to be given to the Buyer pursuant to clause 14.
- (g) In "Writing" is any memorandum or letter signed on behalf of the Seller by a duly authorised representative. In the case of a letter sent to the Buyer the Seller shall be entitled to assume that its terms are agreed unless notified to the contrary in writing within 7 days.

2. THE CONTRACT

- (a) The Goods are sold subject to the Conditions which shall supersede all other terms and conditions, representations or undertakings made by the Buyer or the Seller or otherwise and nothing said or written during the course of negotiations between the Buyer and Seller shall have contractual or other legal effect unless agreed in accordance with the Conditions.
- (b) The Contract shall not be varied unless the Seller expressly agrees the variation in Writing or the Conditions expressly provide otherwise.
- (c) The giving of any delivery instructions, the acceptance of or payment for the Goods or any conduct in confirmation of the transaction hereby contemplated shall constitute unqualified acceptance by the Buyer of the Conditions.
- (d) The buyer can only cancel the contract with written consent of the seller. Cancellation charges may be imposed.

3. PRICE

Unless otherwise agreed in Writing the price of the Goods shall be calculated in accordance with the Seller's price list in force at the date of delivery of the Goods.

4. PAYMENT

- (a) Payment is due by the end of the month following the month during which risk passed to the Buyer, unless other terms have been agreed in Writing. These terms of payment must be strictly observed. If the Buyer is in breach of the Contract then all payments shall become immediately due and payable.
- (b) If any sum due hereunder or any other sum due to the Seller is not paid in full by the due date or if before such date the Seller believes that the Buyer is unable or unwilling to make such payment in full then the Seller shall have the right either to suspend delivery of the Goods pending payment of such sums or to terminate the Contract forthwith.
- (c) Interest shall be payable by the Buyer from the date by which payment should have been made till the date of payment (both before and after judgement) on the unpaid amount on a daily basis at the rate of 4% per annum above the base lending rate of Danske Bank from time to time in force unless otherwise specified.
- (d) The Buyer shall not be entitled to withhold payment of all or any of the purchase price while any claim in relation to the Goods or other dispute is being investigated by the Seller and without limitation no deduction shall be made by the Buyer in respect of any set-off or counter-claim howsoever arising.

5. DELIVERY

- (a) The place of and the date of delivery shall be as agreed between the Buyer and the Seller. However the date for delivery is the Seller's best estimate based on present information and subject to sub-clause below.
- (b) The Seller shall not be liable for delay in delivery in any circumstances whatsoever (even if caused by the negligence of the Seller its servants or agents) nor for any loss, damage or expense which the Buyer may suffer by reason of such delay.
- (c) If the date of delivery is important to the Buyer the Seller is prepared to provide a definite date of delivery provided that the date and a limit on the Seller's liability under this sub-clause have both been agreed in Writing as a variation to the Contract.

6. RISK, ACCEPTANCE AND IN STORAGE

- (a) The risk in the Goods shall pass to the Buyer on the sooner of the Buyer paying the price in full or the Buyer taking delivery of the Goods or the Seller notifying the Buyer that the Goods are ready for delivery and the Buyer having failed to take delivery of the Goods for whatever reason.
- (b) Without limitation after risk has passed to the Buyer if the Goods or any item there of are lost, damaged or destroyed from any cause whatsoever (including the negligence of the Seller, its servants or agents) whether or not the Goods are still in the possession of the Seller then the Buyer shall remain liable to pay the price of the Goods in full and if the Seller repairs the Goods the Buyer shall pay the reasonable cost of repairing the Goods.
- (c) Any change in Delivery Time or the collection date agreed upon between the Seller and the Buyer following the award of the contract or the placing of the order for the Goods by the Buyer will not alter the Seller's production scheduling operations and the Seller shall be entitled, for Goods actually completed and stored by the Seller for delivery or collection after the end of the Delivery Period originally agreed upon, to a storage levy charge equal to zero decimal five percent (0.5%) of the contract value of the Goods so stored for each week of storage commenced until said Goods have actually been delivered or collected provided however that no such storage charge shall be owed by the Buyer if the delay in delivery or collection is due to any reason for which the seller is liable.
- (d) The seller may in some instances waive the storage charge if the buyer shall agree to be invoiced and pay for the goods.

7. TITLE TO THE GOODS

- (a) Property in Goods shall not pass to the Buyer until the Buyer has paid to the Seller the whole of the price of the Goods in full and any other payments due from the Buyer.
- (b) Until the payments referred to in sub-clause (a) above have been made in full the Buyer shall hold the Goods as fiduciary agent for the Seller and shall mark the Goods with an indication that they remain the Seller's property, and they shall be kept separate and identifiable from any other products in the Buyer's possession and shall be returned to the Seller upon request and all the incidence associated with a fiduciary relationship shall apply.
- (c) Without prejudice to any of the Seller's other remedies the Seller shall have the right with or without prior notice at any time to retake possession of the whole or any part of the Goods (and for that purpose shall be granted an irrevocable licence to go upon any premises occupied by the Buyer or which the Buyer is entitled access to) and to dismantle the Goods or detach the Goods from any items in which they may have been incorporated.
- (d) The Buyer shall indemnify the Seller against all costs and liabilities which the Seller incurs in retaking possession of the Goods (or any part thereof) or in exercising any of its rights under this Clause including without limitation any liability in respect of any damage (including damage caused to such premises in such retaking of possession and removal of goods) which it was not reasonably practicable to avoid.
- (e) If any of the Goods supplied by the Seller are incorporated or used as material for other goods before title has passed to the Buyer the property in the whole of such goods shall be and remain with the Seller until such payment has been made. Any sale of such goods by the Buyer shall take place upon the basis that the buyer shall hold on trust for the seller with effect from the date of receipt of the sale proceeds by the Buyer such proportion of those proceeds as is equal to the outstanding price payable by the buyer to the Seller for the Goods.

8. ACCEPTANCE OF GOODS

Unless the Seller is notified to the contrary in writing within 3 days of the date of actual delivery the Goods shall be deemed to have been accepted by the Buyer as being in good condition and in accordance with the Contract.

9. FORCE MAJEURE

- (a) Without prejudice to the other terms of the Conditions the Seller shall not be liable if manufacture or delivery or installation is prevented, hindered or delayed by reason of strikes, sit-ins, trade disputes, lock-outs or any other actual or threatened industrial action or by difficulty in obtaining labour, plant, materials or bought in components or by breakdown of plant or machinery (including transport) or by interruption of power supplies, or by fire or by legal action by a third party (whether or not any of the aforesaid are caused by the negligence of the Seller, its servants or agents) or by reason of any circumstances outside the Seller's control which shall include, but not be limited to national emergency, war, civil riot, intervention by Government and all other cases of force majeure.
- (b) If the manufacture or delivery of the full quantity of Goods due under the Contract is prevented, hindered or delayed by reason of any circumstances within sub-clause (a) for a period greater than 3 months after the agreed delivery date then both the Seller and the Buyer shall be released from their respective obligations in respect of any goods which have not been delivered by that time.

10. PACKING

- (a) Where specified in the Seller's sales literature the cost of the Goods will include the cost of packaging. Such packaging shall be non-returnable and suitable for the protection of the Goods under normal transport conditions and for dry indoor storage in temperate climates for up to 3 months from the date of such delivery provided that the packaging is not damaged or disturbed.
- (b) All other goods will (unless otherwise agreed in Writing) be delivered by the Seller without packaging. Where the Seller so agrees the packaging will be as agreed and if not specified will be non-returnable and suitable for the protection of the Goods under normal transport conditions and for dry indoor storage in temperate climates for up to 3 months from the date of such delivery provided that the packaging is not damaged or disturbed. The Seller shall be entitled to make an additional charge as agreed with the Buyer or (if no charge has been agreed) a reasonable charge for packaging. The additional charge will be payable by the Buyer at the same time and on the same terms as the price of the Goods.

11. TRADE NAMES AND TRADE TERMS

- (a) The Buyer undertakes not to hold himself out in any circumstances or in any manner whatsoever as having authority to sell, service, maintain or deal with the Goods as agent or dealer or other authorised representative of the Seller.
- (b) In particular and without prejudice to the provisions of sub-clause (a) the Buyer undertakes not to use or reproduce any trade name or registered trade mark of the Seller on goods, premises, vehicles, letter headings and other stationery, sales literature or in any way whatsoever and not to do or authorise to be done any infringing act to which the Trade Marks Act 1994 applies.
- (c) The Buyer's undertakings under this Clause are conditions of this Contract so that any breach thereof shall entitle the Seller to terminate the Contract and to recover damages in respect of all loss, damage and expense occasioned thereby. The Seller at its option shall be entitled to recover the profit made by the Buyer during the period of the breach from sales, servicing, maintenance and other dealings with goods manufactured by the Seller.
- (d) Notwithstanding the terms of the Conditions no document purporting to authorise the Buyer to do any act which would otherwise be a breach of the Buyer's undertakings under this Clause or purporting to consent thereto on behalf of the Seller shall be binding on the Seller unless it is a formal licence agreement bearing the Seller's corporate seal.

12. DRAWINGS, PRINTS AND SPECIFICATIONS

- (a) Any technical drawings, prints and specifications supplied by the Seller under or in connection with a quotation or the Contract shall remain the property of the Seller who shall reserve the copyright, design right and any registered design right therein. The Buyer shall not copy them or communicate their contents to any third party without the Seller's consent (which consent shall not be unreasonably withheld) and shall comply with the Seller's reasonable requirements as to their use, return and otherwise.
- (b) The property in the design of the Goods shall (subject to any existing rights of any third party or the Buyer in any design or invention incorporated or used in the design of Goods) remain the exclusive property of the Seller and neither the buyer nor any agent contractor or other person authorised by the Buyer nor any other person, firm or company shall at any time make use of the design or any part thereof.
- (c) The Seller gives no warranty or indemnity in respect of any actual or alleged infringement of any patents, registered designs, design copyright, or any other industrial property right relating to the Goods.

13. DESCRIPTION OF GOODS

- (a) Illustrations, photographs, descriptions (including descriptions relating to technical performance, capacity, output, consumption and dimensions) and general literature relating to the Goods are intended as a general guide only and such material shall not form part of the Contract. The Goods will not necessarily correspond in all respects with the goods shown in those illustrations and photographs or such descriptions or general literature. Without limitation the Seller reserves the right to make without notice to the Buyer any improvement or alteration in the material, specification, dimensions or design of the Goods which it thinks reasonable or desirable or which it is required to make by law and such improvement or alteration shall be deemed to have been accepted by the Buyer and the Seller as a variation to the Contract.
- (b) The Seller can provide goods which are suitable to meet the Buyer's purpose or which will meet specified technical performance provided that the Buyer provides written details of its requirements and obtains the Seller's advice (as to which goods will be suitable) in Writing. Unless the Seller has agreed in Writing to provide equipment for a specified purpose or of a specified technical performance the Buyer shall be deemed to have selected the Goods without having made its purpose or requirements known to the Seller.

14. WARRANTY

- (a) Subject to clause 16 the Seller warrants to the Buyer that as from the date of supply and for a period of twenty four months from date of dispatch (as to which the Seller's determination is final) the Seller will free of charge replace or repair any part or parts thereof proved to the Seller's satisfaction to be defective owing to faults in workmanship of the Seller or materials comprised in the Goods. All labour, travel and carriage costs involved in effecting such replacements or repairs will be borne by the Buyer.
- (b) If the Buyer requires a warranty greater than that set out above any such warranty to be effective must be in writing and signed by either the Secretary or a Director of the Seller and shall in any event be limited to the amount that the Seller can recover under the product liability insurance policies held by the Seller at the date of the Contract.
- (c) Save as expressed in this Clause the Seller shall be under no liability for any personal consequential or other loss or damage of whatsoever kind or howsoever caused as a result of any goods supplied or work done being defective or not in accordance with any order or as a result of anything done or omitted in connection with any work done or omitted to be done by the Seller including any breach by the Seller of any fundamental term of any order and the Seller's liability under this Clause shall be in lieu of and to the exclusion of any liability, condition, guarantee, warranty, term undertaking or representation whether express or implied, statutory or otherwise and shall in any event be limited to the value of the Goods to which any claim relates or the amount received by the Seller in relation to the Goods under any product liability insurance held by the Seller at the date of the Contract.
- (d) Nothing contained in the Clause shall exclude:
 - (i) any liability for breach of the Seller's implied undertakings as to title
 - (ii) where the Buyer deals as a consumer (as defined by the Unfair Contract Terms Act 1977) any liability for breach of the Seller's implied undertakings as to conformity of goods with description or sample or as to their quality or fitness for a particular purpose.
 - (iii) any liability arising from the Seller's negligence causing death or personal injury.

15. EXCLUSIONS

The Warranty shall not apply to:-

- (a) Any defect which in the opinion of the Seller arises by reason of misuse, misapplication, neglect or accident occurring after risk has passed to the Buyer.
- (b) Any defect not notified to the Seller or its authorised distributors or dealers within 3 working days of the Buyer having become aware of such defect.
- (c) Any equipment which shall in the opinion of the Seller have been improperly installed, serviced, repaired or altered (other than by the Seller) or in or to which any part not manufactured or sold by the Seller has been fitted.
- (d) Goods not of the Seller's manufacture in which case the Buyer is entitled only to such benefit as the Seller may receive under any warranty given in respect thereof.
- (e) Any equipment on which service has been carried out by anyone other than the Seller or any approved service agent.
- (f) Any equipment installed or situated outside United Kingdom of Great Britain & Northern Ireland, Isle of Man, Republic of Ireland, Eire and the Channel Islands without the Seller's consent in Writing.

16. TERMINATION OF THE CONTRACT

If the Buyer becomes insolvent or goes into bankruptcy, receivership, administration or liquidation or enters into any voluntary arrangement with its creditors or commits a breach of the Contract or any other contract with the Seller or has any process of distress or execution levied upon its goods or the Seller reasonably considers that any of the above events is likely to occur then the Seller may forthwith on written notice to the Buyer terminate the Contract without incurring any liability to the Buyer and without prejudice to the Seller's right to recover the Price and / or damages for any breach of the Contract by the Buyer.

17. MISCELLANEOUS

- (a) The Contract is between the Seller and the Buyer as principals and is not assignable without the Seller's consent.
- (b) Each of the Clauses and sub-clauses of the Conditions shall be construed as separate and severable.
- (c) None of the provisions of any of the clauses or sub-clauses of the Conditions shall in any way limit any of the other clauses or sub-clauses of the Conditions.
- (d) The law governing the Contract shall be the law of England. Any disputes arising out of or in connection with the Contract shall be submitted to the jurisdiction of the English Courts, except that the Seller may elect and be entitled to proceed in Scotland or Northern Ireland or any foreign jurisdiction wherever proceedings may lawfully be brought against the Buyer.
- (e) The Buyer recognises that the Conditions and (without limitation) the limitations of liability contained in the Conditions are reasonable in that the prices quoted by the Seller are dependent upon such limitations being incorporated in the Contract and because greater liability can be accepted if expressly agreed in Writing in accordance with the Conditions.
- (f) Any notice may be served by either party on the other by leaving it at or sending it by post or facsimile to the address of the party contained in the Contract. Such notice shall be deemed to be served if by hand when delivered if by facsimile when sent and if by first class post two working days after posting.

Warranty Procedure

For products and services supplied directly by Kelvion, you should follow the procedure outlined below. For products supplied via a wholesaler, distributor or agent, your warranty agreement is with them and therefore you should supply the same information as outlined below to your contact.

Warranty Procedure

This warranty applies to all units detailed in this list price and, unless otherwise stated in product literature or specific contracts, provides for a manufacturer's guarantee of twenty four months from date of dispatch against faults in workmanship or materials.

When submitting a warranty claim, a claim number will be supplied. Please give the following information in order to process your claim quickly and efficiently:

- Customer's original reference job number / order number.
- Kelvion's job number / advice note number.
- Type of unit and serial number.
- Date of installation.
- Details of defect.

When providing details of the defect, please give as much information as possible, ie.

- Was the unit satisfactory on delivery?
- Frequency of fault (continuous / intermittent)
- Is the unit leaking ? (+ location of leak)

Items manufactured by Kelvion:

No work should be undertaken to resolve the problem either by the customer or a third party until approved by Kelvion – failure to do so could invalidate the warranty.

The item may be replaced or rectified if the guarantee claim is valid.

For items that have been installed, Kelvion have the right to decide if rectification on site is suitable and who should undertake the work or whether to return / replace the unit(s). For items where Kelvion decides to replace, the original faulty item must be returned. All items which are returned will be inspected.

If the guarantee claim is not valid the customer will be advised and further instructions requested, either to return the item or to issue an official order to replace or rectify the item.

If you require a replacement product the buyer will be asked to supply a purchase order, when the unit has been returned and evaluated.

The buyer will be notified by Kelvion if the claim is valid.

Items NOT manufactured by Kelvion:

- The item will be replaced and the customer will be invoiced
- The item will be returned to the supplier for evaluation.
- If the claim is valid the credit received from the supplier will be passed on to the customer.

Items supplied by Kelvion DAWMEC

- The item will be replaced and the customer will be invoiced.
- The item will be returned to the supplier for evaluation.
- If the claim is valid, the credit received from the supplier will be passed on to the customer.

www.kelvion.com