

Reliable and efficient cooling

This low profile range of NS unit coolers continues the GEA Searle philosophy of energy efficient product design. With a capacity range from 1.69 kW up to 6.93kW and 6mm fin spacing, these coolers are suitable for both high and low temperature applications.

NS Air Cooler

Reliable and efficient cooling

The heat exchanger incorporates Searle'D' fin with extended inner surface copper tube which has proved very popular since its introduction. Its unique coil geometry is highly efficient and provides a high secondary surface on which to deposit frost and extend initiation times between defrost cycles. The range is certified for its performance by Eurovent (see below) and the capacities listed are in accordance with its strict rules.

Casework

All the coolers are constructed from aluminum sheet panels to form a rigid but lightweight structure. To enable the unit to be lifted directly into place the drain tray is constructed from pre-galvanized steel. There are key hole slots in the top plate to allow the cooler to be fitted flush to the ceiling thereby limiting the opportunities for bacterial growth. The end covers are secured by only two screws, thus making removal quick and easy for installation and service needs.



Coils

Standard (Cu/Al) coils are manufactured from copper tube (with extended inner surface) mechanically expanded into aluminum fins. The metric fin spacing of 6mm, this equates to approximately 4 fins per inch. All coils are tested to 35.8 bar using dry air down to -40°C dew point. The Searle 'D' fin which has been specially developed for refrigeration applications, ensures optimum heat transfer efficiency combined with minimum defrost demand and low refrigerant charge. The units have been designed with the refrigerant connections located at the left hand side when looking at the fans.

Distribution System

Good refrigerant distribution is essential to achieve maximum and stable performance from any system. The NS coolers have been thoroughly tested to determine the ideal distribution system to operate over the wide range of conditions expected. The NS14 can be used with an internally equalized TEV. All other units must use externally equalized TEV's.

Motors and Fans

All units use 1300rpm 18 Watt shaded pole motors fitted with 5 bladed 254mm diameter fans. These components were selected after extensive testing and trials. These 4 pole motors conform to IP42 and are suitable for 230V-1ph-50/60 Hz supply. They are individually connected back to a terminal box via a push on plug and socket which allows the motor fan assembly to be quickly and easily dismantled for service purposes.

Defrost

The low temperature versions of these coolers employ electric defrost systems comprising two stainless steel hairpin heater elements fitted into the coil block and one to the coil base plate. Extensive testing has been carried out to determine the optimum heater wattage necessary to clear frost formation whilst minimising power input and the risk of steaming. The heaters are individually wired to the terminal box located at the opposite end to the refrigerant connections.

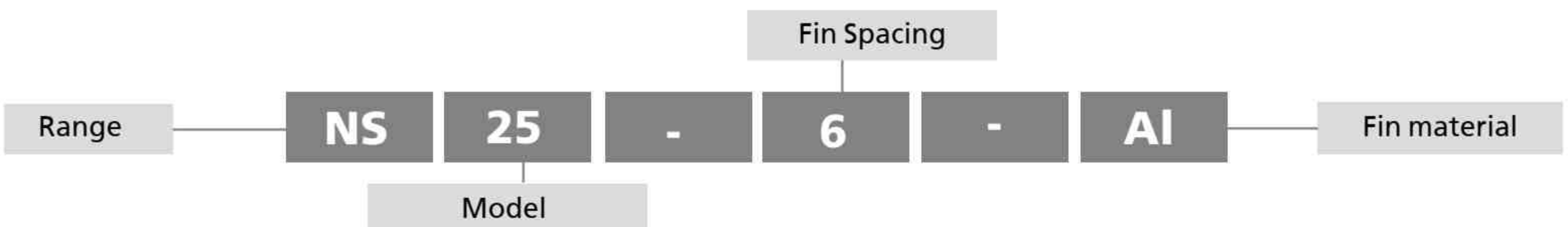

NS Selection Data

Model	R404A Capacity @ SC2	Fan and motor specifications 230 - 1ph 50Hz								Coil data		Connections		Electric defrost
		No of fans	Air volume	Air throw (***)	Noise level (**)	Total power input †	Motor size	F.L.C per fan	SC per fan	Surface area	Internal volume	Inlet	Outlet	
	kW*	m ³ /s	m	dBA	W	W	A	A	m ²	dm ²			W	
NS14 - 6	1.69	1	0.24	6.0	53	70	18	0.55	1.5	9.02	2.48	1/2"	1/2"	1.29
NS25 - 6	2.74	2	0.50	6.5	56	140	18	0.55	1.5	12.02	3.01	1/2"	5/8"	2.21
NS28 - 6	3.44	2	0.49	6.0	56	140	18	0.55	1.5	18.04	4.52	1/2"	5/8"	2.25
NS37 - 6	4.13	3	0.75	6.5	58	210	18	0.55	1.5	18.04	4.52	1/2"	7/8"	3.18
NS43 - 6	5.18	3	0.73	6.0	58	210	18	0.55	1.5	27.06	6.56	1/2"	7/8"	3.24
NS57 - 6	6.73	4	0.97	6.0	59	280	18	0.55	1.5	36.07	8.60	1/2"	7/8"	4.23

Notes:

Rating conditions:

The duties shown in this catalogue are at EN 328 Standard Condition 2 (-8°C saturated suction temperature, 0°C air entering). For data on refrigerants not shown, please contact your supplier.

* DT₁ is the difference between the entering air temperature and the saturated suction temperature at the outlet of the cooler.

** Noise levels are based on free field conditions at a distance of 3m. Actual noise levels will depend upon cold store construction, store loading and the number of coolers installed.

*** Terminal air velocity 0.25m/s, free air conditions at 10°C. Air throw cannot be considered on absolute value because many factors have a substantial effect on the distance achieved.

† Total Power Input at Standard Condition 2 (-8°C saturated suction temperature, 0°C air entering).

Refrigeration	R404A	R134a	R507A	R407A/F	R407C
Capacity factor (dew point, DT ₁)	1.00	0.91	0.97	1.18*	1.35*
Refrigerant charge density (kg/dm ³)	0.312	0.338	0.313	0.332	0.332

* Capacity factors for refrigerants with high glide apply only at the nominal rating condition. Refrigerant charge densities are based on 25% of the internal volume being liquid.

NS Cooler DT₁ - WET

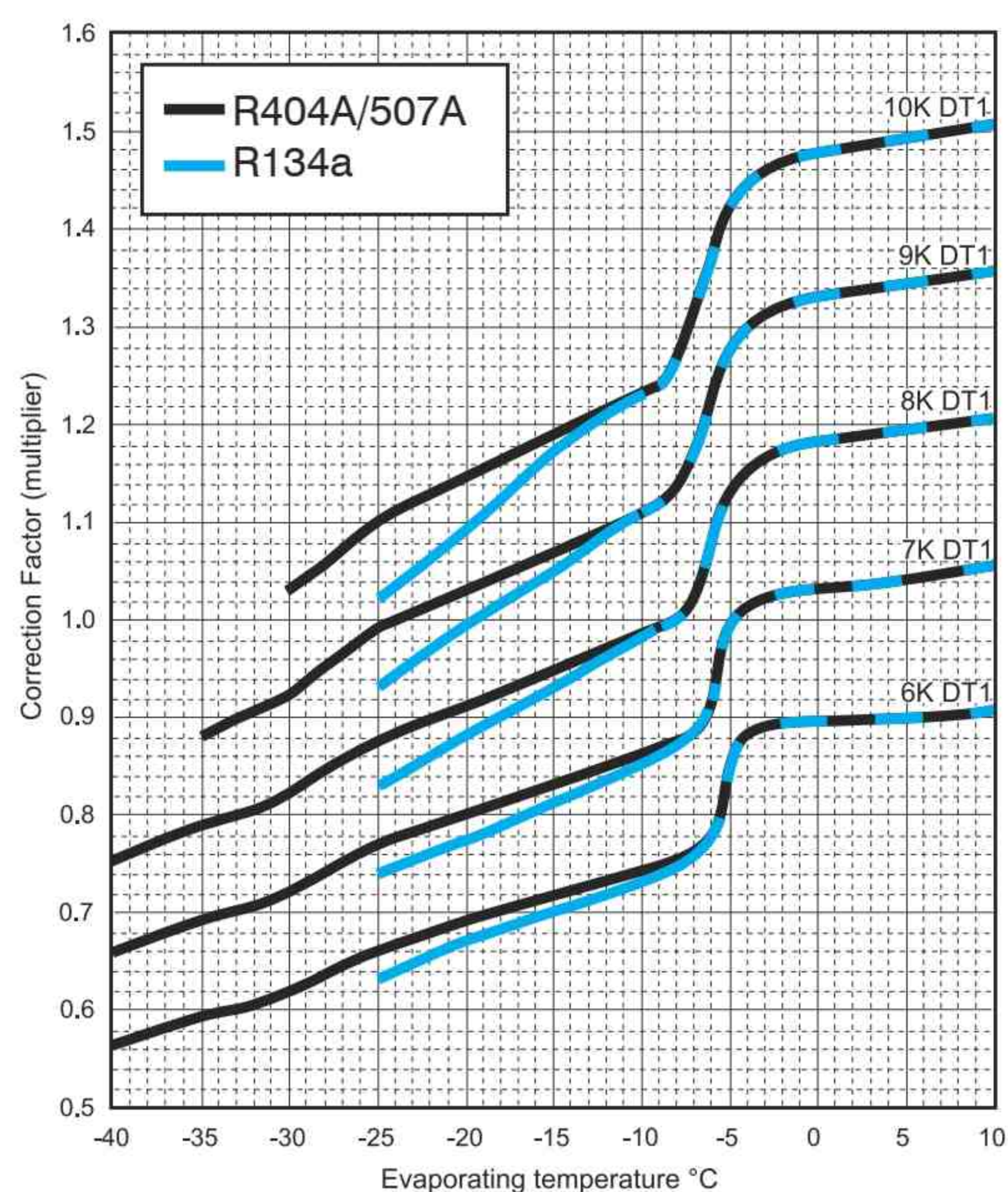

Correction factors

(Multiply capacity by appropriate correction factor to give performance at chosen conditions)

Note: For R407, DT₁ is calculated from mid point evaporating temperature.

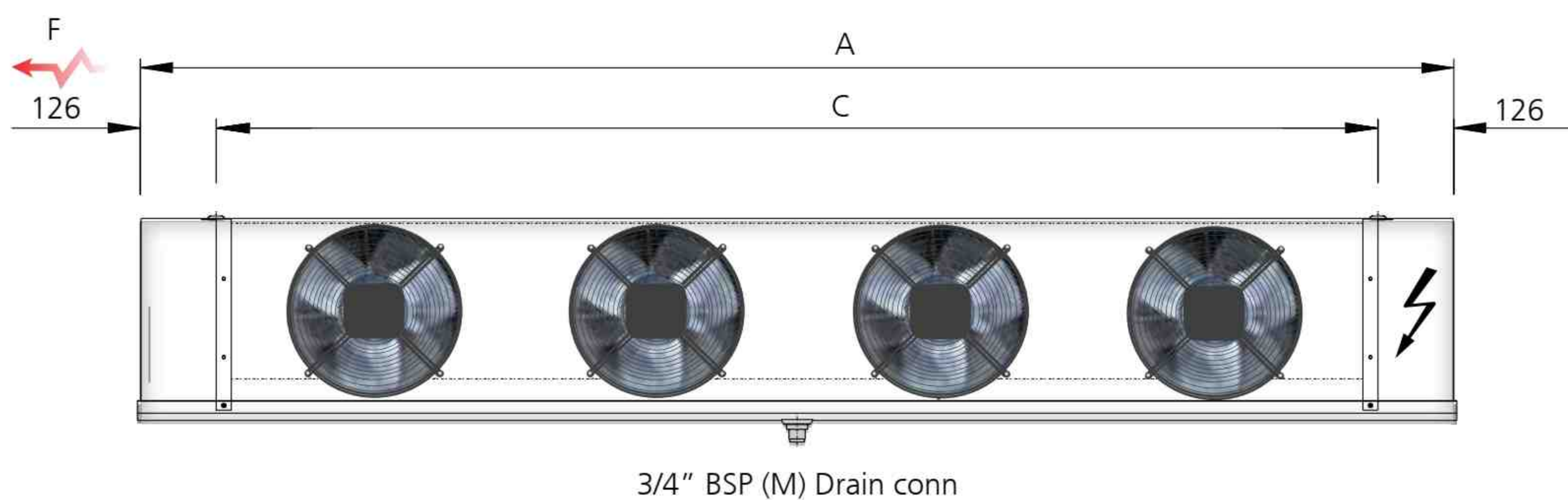
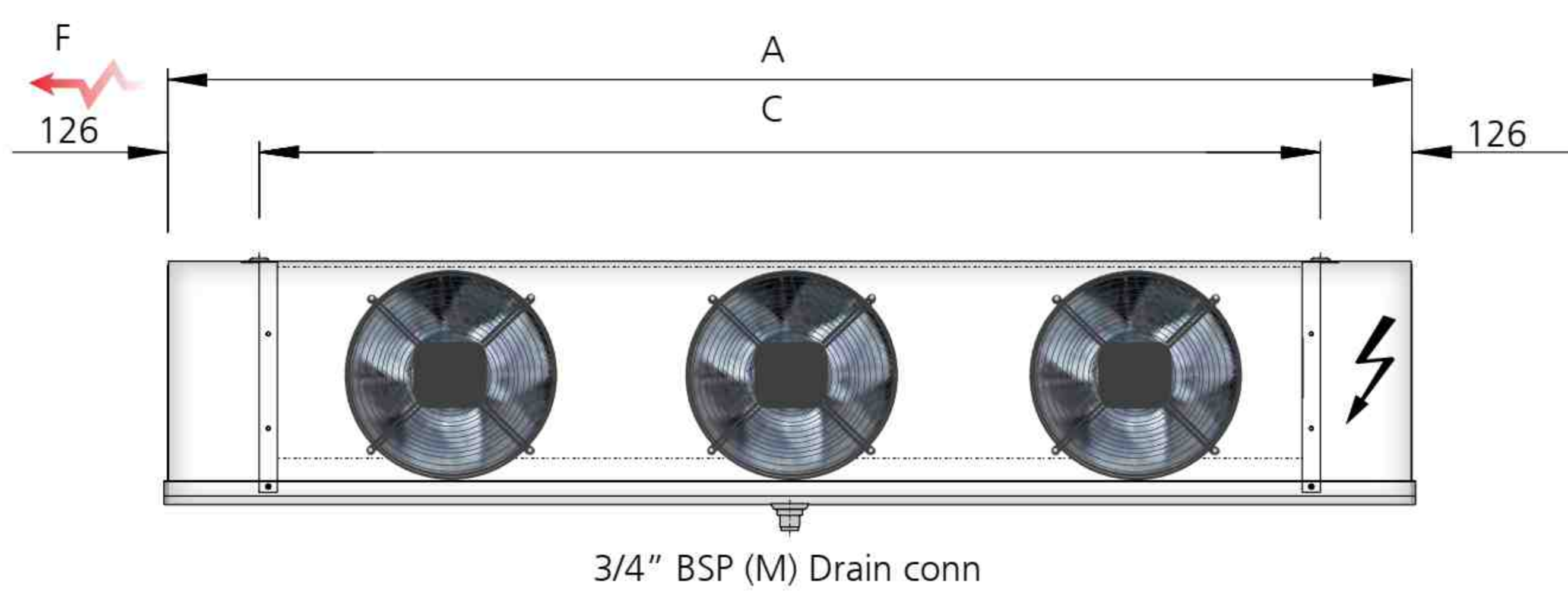
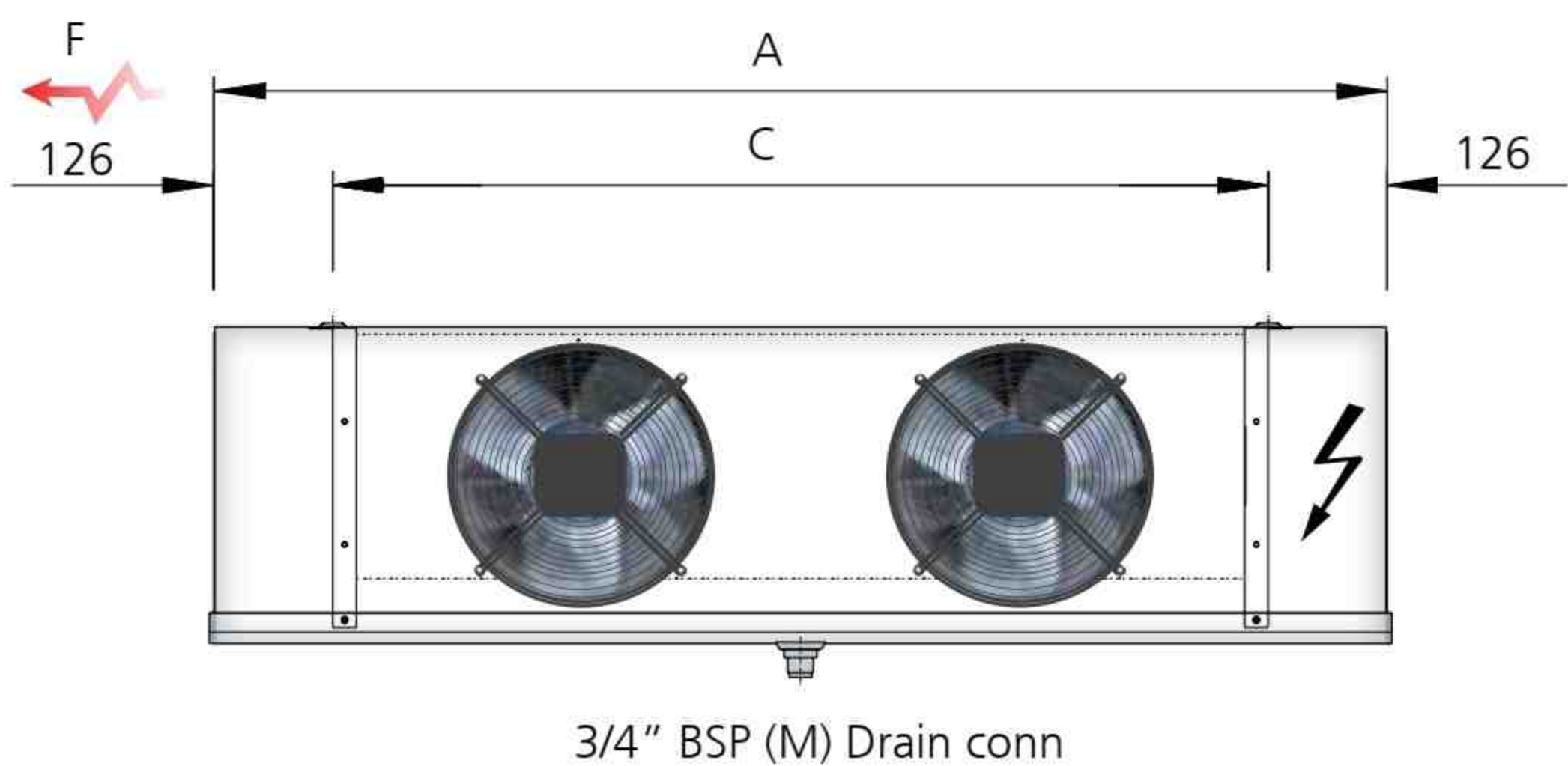
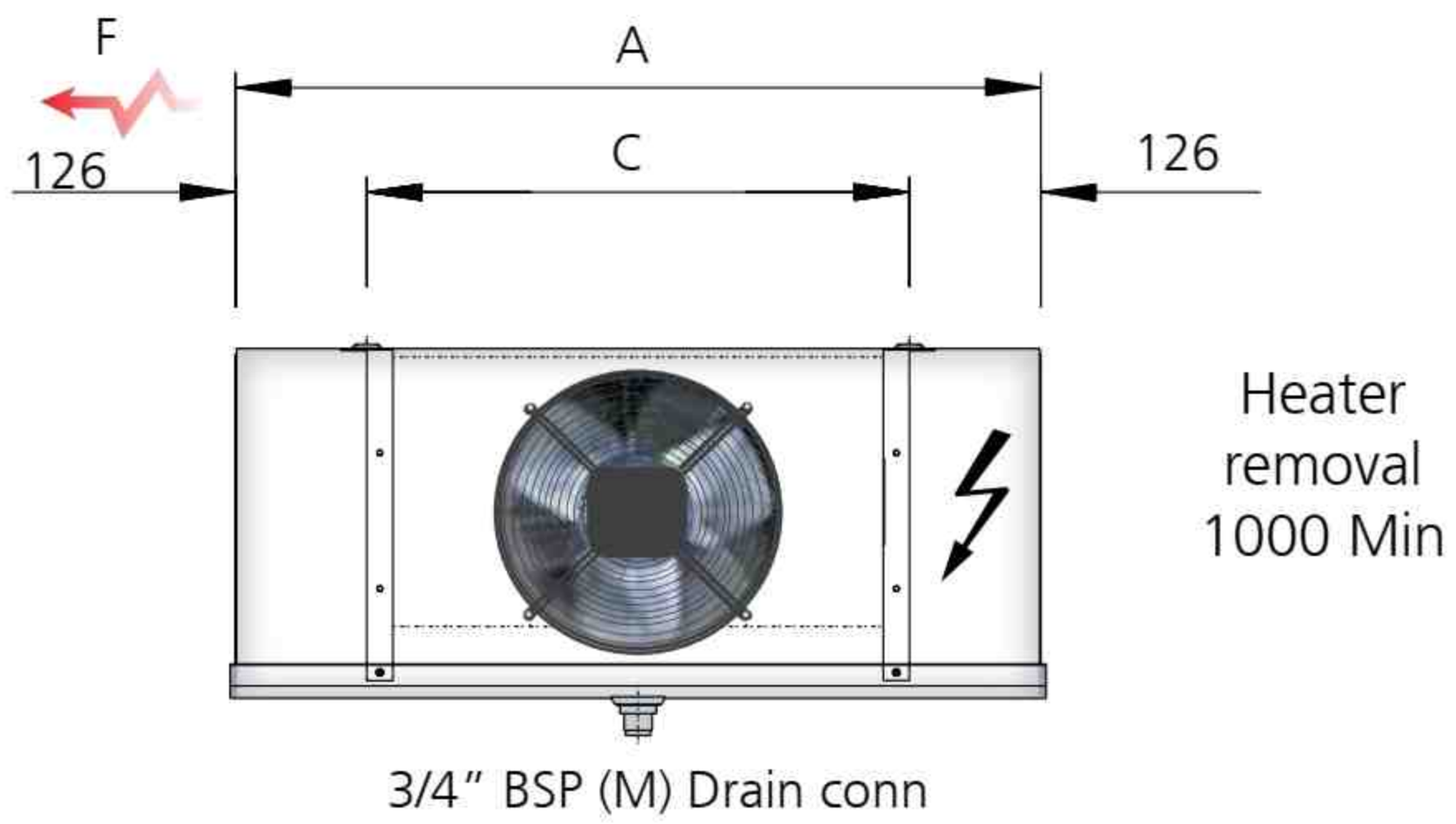

Min HTR Unit to wall

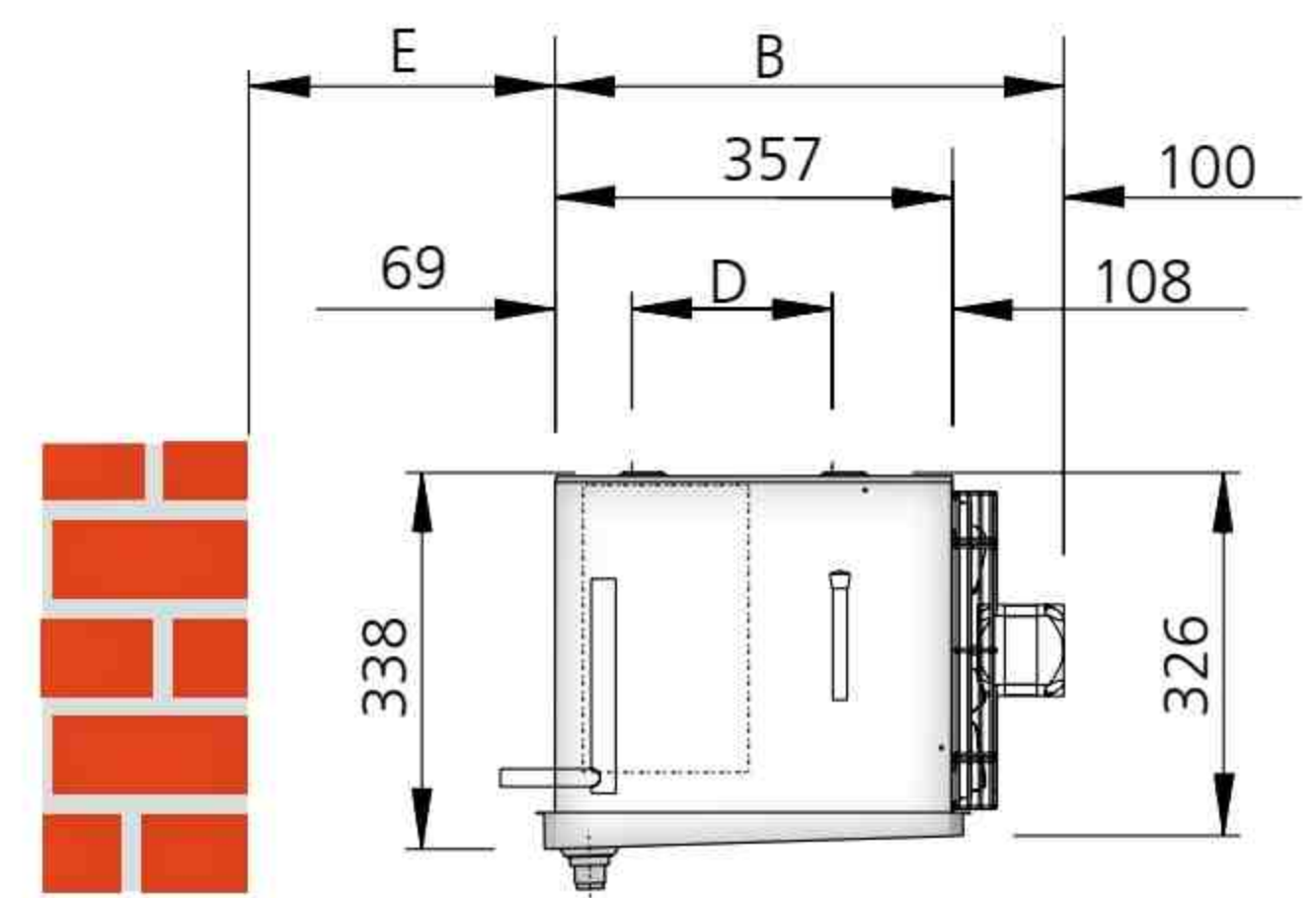

Key hole slot

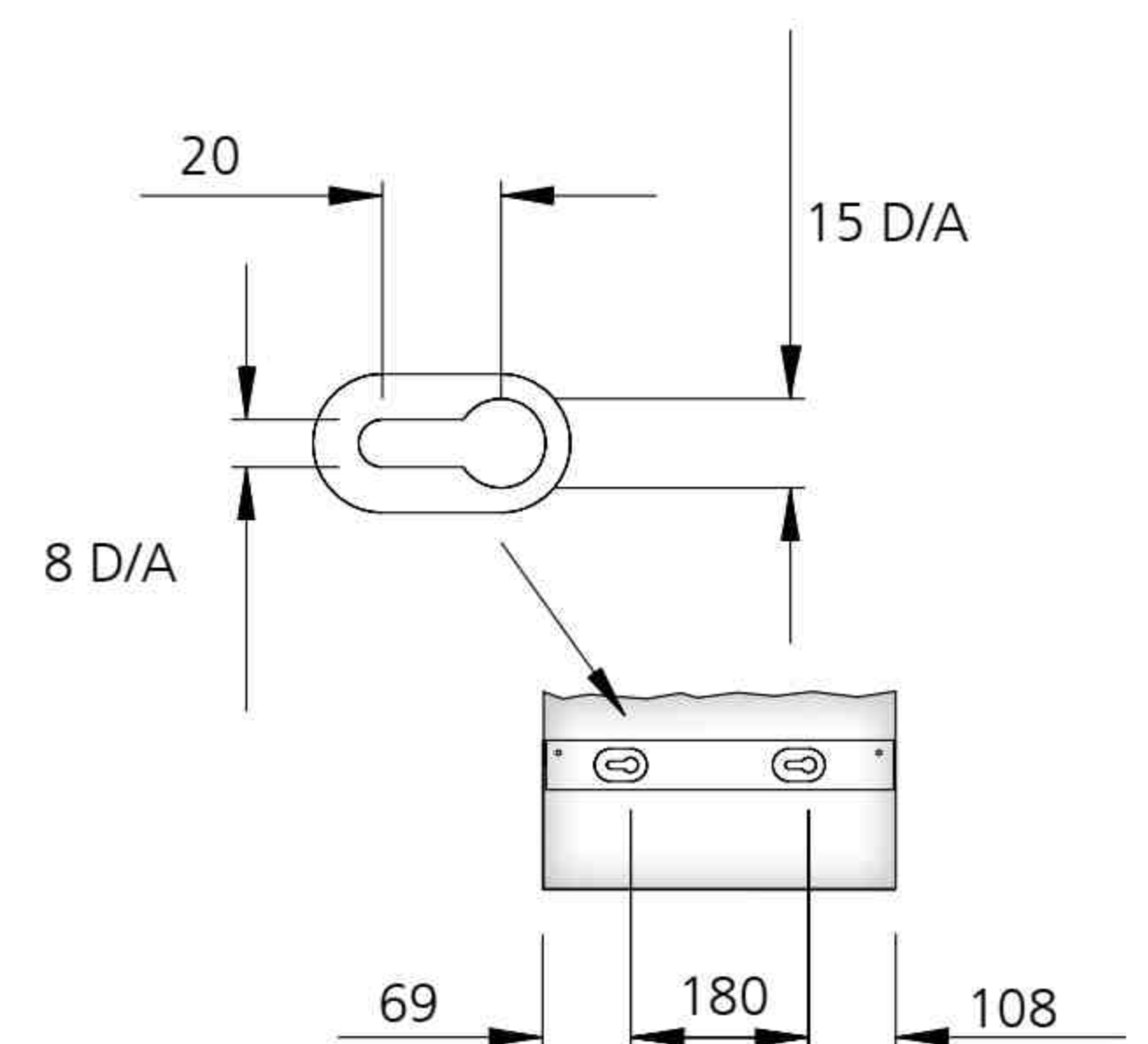

'F' = Min heater Withdrawal

All dimensions in mm unless otherwise stated

NS Dimensions (mm)

Model	Overall		Mounting centres		E	F	Dry Weight kg
	A	B	C	D			
NS14 - 6	772	457	520	180	275	550	15
NS25 - 6	1242	457	990	180	275	1020	22
NS28 - 6	1242	457	900	180	275	1020	26
NS37 - 6	1712	457	1460	180	275	1200	31
NS43 - 6	1712	457	1460	180	275	1200	36
NS57 - 6	2182	457	1930	180	275	1200	46