

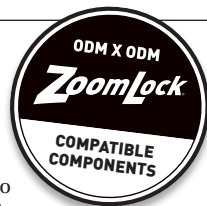

Suction Line Filter-Driers and Suction Filters

INSTALLATION AND SERVICING INSTRUCTIONS
SD-51 / 22021

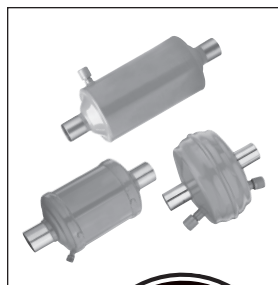

GENERAL SUGGESTIONS

Suction Line Filter-Driers and Suction Filters should be installed as close to the compressor as possible. If a suction vibration eliminator is used, the drier or filter should be installed upstream of it. Suction Line Filter-Driers and Suction Filters may be installed either in a **horizontal** or **vertical** position. If the vertical position is used, the flow should be downward to prevent oil trapping. Always install the unit with the **flow direction** as specified on the product label.

Use a **support bracket** with the Suction Line Filter so its weight does not add undue strain to the refrigerant line. The A-685 bracket can be used with types SF-6417-T, SF-6421-T, and the C-430-S-T-HH Series Filter-Driers.

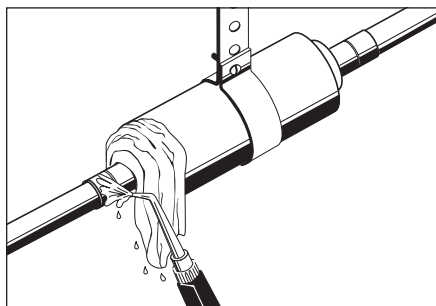

All sealed model suction line filters and filter-driers have copper fittings. It is not necessary to clean the fittings prior to brazing.

Any **brazing alloy** may be used, including Sil-Fos, Phos-Copper, silver solder, or soft solder. It is suggested that a **wet cloth** be wrapped around the end of the shell, and that the flame be directed away from shell to protect the paint from deterioration by the heat of brazing. Avoid touching the paint while it is soft from the heat of brazing. These precautions will maintain the corrosion protective finish and prevent rust in service.

The Suction Line Filter-Driers and Suction Filters are dehydrated and sealed. Do not remove the seals until ready for installation to prevent moisture pickup from the atmosphere.

When a need exists, a Suction Line Filter-Drier can be used in a liquid line application. The construction of both types is similar, except the Suction Line Filter-Drier has larger connections and an access valve. The performance characteristics of the two drier types are similar.

SPECIAL SUGGESTIONS FOR PARTICULAR TYPES

-T, -TT MODELS WITH ACCESS VALVES

These types have an access valve on the inlet end or both the inlet and outlet to permit **pressure drop readings** during clean-up. The access valve can also be used for charging purposes. The valve cores are shipped in a separate envelope in the box. No additional charge is needed when filter-drier is installed in the suction line of a system.

The **valve core** should be installed after the unit has been brazed in the line, and after it has cooled to room temperature. Insert the core and tighten with a tire valve wrench. The proper torque is 1-1/2 to 3 inch-lbs. When properly installed the tip of the access valve actuator will be no more than 1/32" below the end of the flare fitting. Use the seal cap supplied as a further precaution against leaks.

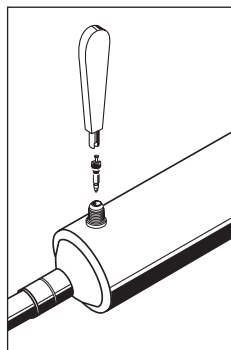

During brazing, the access valve will serve as a vent to relieve internal pressure or as a port for entry or venting of dry nitrogen. Passing dry nitrogen through the joint during brazing is recommended to prevent the formation of copper oxide scale on the inside of the line.

ZOOMLOCK® INSTRUCTIONS*

The Type PZK models with ODM X ODM connections are compatible with ZoomLock® MAX press-to-connect fittings and ZoomLock® PUSH push-to-connect fittings.

ZoomLock MAX

1. Deburr and clean copper to ensure tube ends are free and clear of any residual burrs, oxidation, dirt or debris. Use the ZoomLock MAX depth gauge to determine the proper insertion depth. Mark the tubing with a permanent marker to indicate proper insertion depth on every tube.

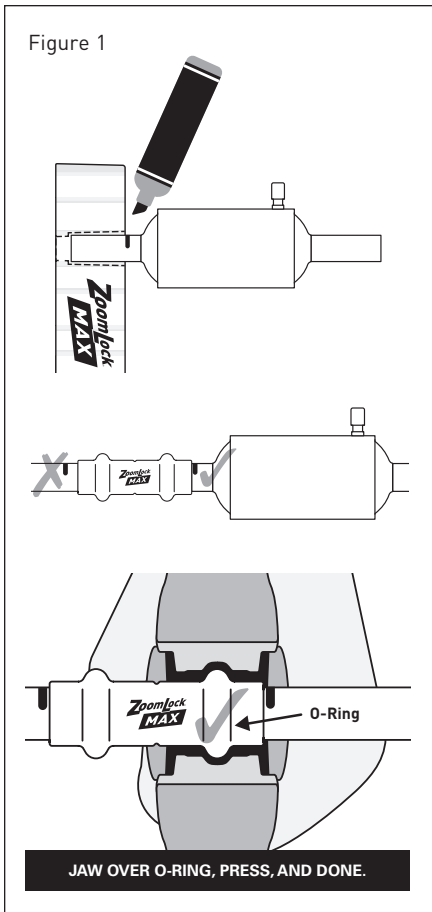

2. Push the ZoomLock MAX fitting onto the tube. Use the mark to assure insertion depth and secure fit.
3. Use the grooves in the jaws as a guide to properly place the crimping jaws onto the fitting. (See illustration below for proper crimping alignment.) Press and continue to hold the trigger on the ZoomLock MAX Crimping Tool until the tool completes its cycle. Once the tool has completed a full cycle, the crimp is complete.

NOTE: The Type PZK ODM X ODM models can be brazed into the ODF solder connections of other components or tubing using the brazing instructions contained herein.

**COMPACT MODELS
C-140 Series**

The C-140-S-TT-HH is specifically designed for cramped piping situations such as heat pumps. However, it is not a reversible filter-drier, therefore it must be installed in the common suction line of heat pump units.

**SUCTION FILTERS
Types SF-285-T through SF-4813-T**

The design of these Suction Filters permit their installation **with** or **without** the optional relief (bypass) feature. When installed with the flow in the same direction as the flow arrow marked on the product “with bypass relief”, this feature will be active.

If the bypass relief feature is not desired, install the Suction Filter “without bypass relief” as indicated on the product. When used on **heat pumps** and systems with hot gas defrost, the Suction Filter should be installed in this direction of flow, without bypass relief.

To effectively use the access valve for pressure drop measurement on these Suction Filters, the filter must be installed without bypass relief.

**SUCTION FILTERS
Types SF-6417-T and SF-6421-T**

These types do not have the bypass relief feature and are always installed in the same flow direction.

If a Suction Line Filter-Drier is dropped, be sure to shake it to see if the core has been broken. Do not install a drier with a broken core since particles might escape and damage the system. Sporlan Suction Filters and Filter-Driers should not be subjected to temperatures below -50°F. All Suction Filters and Filter-Driers

are suitable to use with Refrigerants 22, 134a, 404A, 407A/C/F, 448A, 449A, 450A, 507 and 513A. Suction line filter-driers can be used with R-410A since the shells are qualified to handle the higher working pressure. Listed by Underwriters' Laboratories Inc. - Guide Card

SMGT(7) - File No. SA1756. For more detailed information on **Suction Line Filter-Driers** for clean-up after a hermetic motor burnout see Bulletin 40-10. Additional information on Suction Filters is available in Bulletin 80-10.

*** FOR DETAILED ZOOMLOCK INSTALLATION PROCEDURES, VISIT ZOOMLOCK.COM.
OR POINT AND SCAN THE QR CODE(S) BELOW WITH A CAMERA PHONE.**



ZoomLock PUSH
[Push-to-Connect Fittings](#)
[Catalog K-2](#)

To download, point and scan this QR code with a camera phone.



ZoomLock MAX
[Press-to-Connect Fittings](#)
[Catalog K-3](#)

To download, point and scan this QR code with a camera phone.

⚠ WARNING – USER RESPONSIBILITY

Failure or improper selection or improper use of the products described herein or related items can cause death, personal injury and property damage.

This document and other information from Parker Hannifin Corporation, its subsidiaries and authorized distributors provide product or system options for further investigation by users having technical expertise.

The user, through its own analysis and testing, is solely responsible for making the final selection of the system and components and assuring that all performance, endurance, maintenance, safety and warning requirements of the application are met. The user must analyze all aspects of the application, follow applicable industry standards, and follow the information concerning the product in the current product catalog and in any other materials provided from Parker or its subsidiaries or authorized distributors.

To the extent that Parker or its subsidiaries or authorized distributors provide component or system options based upon data or specifications provided by the user, the user is responsible for determining that such data and specifications are suitable and sufficient for all applications and reasonably foreseeable uses of the components or systems.

