

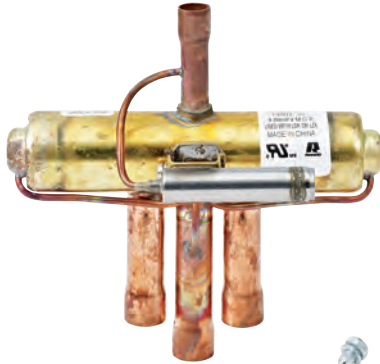

REFRIGERATION

RANCO

REVERSING VALVES



V2-408060-170

V Series

The Ranco® 4-Way Reversing Valves (Generation 4) are designed for heat pump applications such as window-type, unitary and split systems.

They are the key component to provide heating and cooling from the heat pump system by reversing the flow direction of the refrigerant.

These solenoid operated valves are slide type with a 4-way pilot valve, and operate under the full pressure of the heat pump system.

Note: Solenoid coils are not included. Generation 4 type Ranco Reversing Valves work with LDK Series Solenoid Coils.

Specifications

Part Numbers	Description	Capacity Nominal	Capacity R-22	Capacity R-410A	Tube Size Suction	Tube Size Discharge	Style
V2-408060-170	4-Way Reversing Valve	1 ton	0.75 to 2.0 tons	0.9 to 2.2 tons	1/2"	3/8"	A
V2-408060-270	4-Way Reversing Valve	2 tons	0.75 to 2.0 tons	0.9 to 2.2 tons	1/2"	3/8"	B
V2-410060-470	4-Way Reversing Valve	2 tons	1.0 to 2.5 tons	1.3 to 2.5 tons	5/8"	3/8"	D
V2-4100F0-370	4-Way Reversing Valve	2 tons	1.0 to 2.5 tons	1.3 to 2.5 tons	5/8"	3/8" Outer Diameter	C
V3-410080-770	4-Way Reversing Valve	3 tons	1.0 to 2.8 tons	1.3 to 3.1 tons	5/8"	1/2"	E
V3-412080-870	4-Way Reversing Valve	3 tons	1.0 to 3.0 tons	1.3 to 3.5 tons	3/4"	1/2"	E
V6-412080-170	4-Way Reversing Valve	6 tons	1.0 to 5.5 tons	1.3 to 6.7 tons	3/4"	1/2"	A
V6-414080-170	4-Way Reversing Valve	6 tons	1.0 to 5.5 tons	1.3 to 6.7 tons	7/8"	1/2"	A
V10-414080-170	4-Way Reversing Valve	10 tons	3.0 to 9.9 tons	3.8 to 11.9 tons	7/8"	1/2"	A
V10-418140-170	4-Way Reversing Valve	10 tons	3.0 to 11.2 tons	3.8 to 13.5 tons	1-1/8"	7/8"	A
V12-4220T0-270	4-Way Reversing Valve	12 tons	6.0 to 14.0 tons	6.3 to 16.8 tons	1-3/8"	1-1/8" Outer Diameter	F

Product Drawings

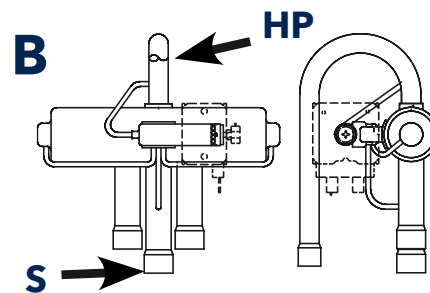
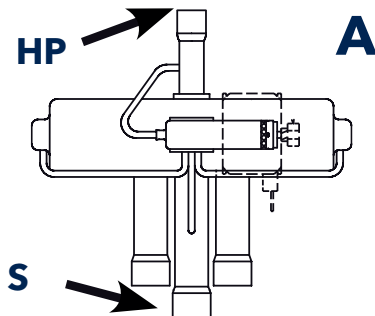



Product Drawings

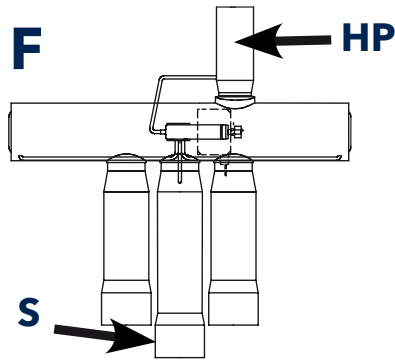
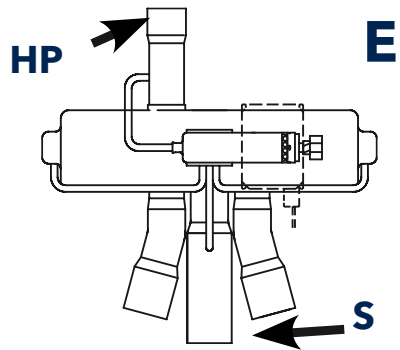
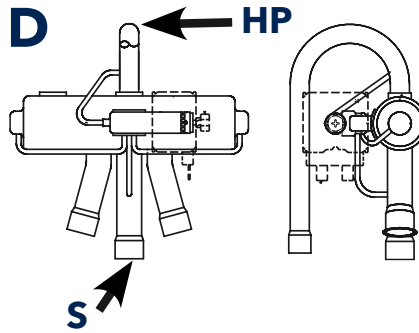
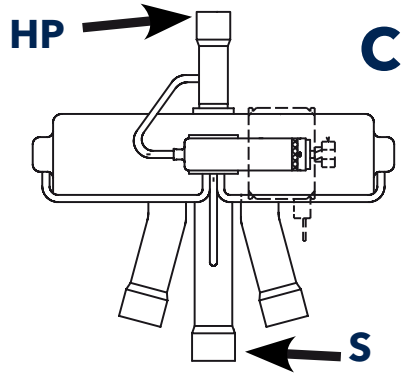

Legend
HP: High Pressure
S: Suction

R
R
A
N
G
O

1 Year
Limited
Warranty

F45