



Tecumseh

Compressor Voltage Code : XG

FH4532Z-XG

High Temp. Commercial (HP)

380-420V 3~ 50Hz / 460V 3~ 60 Hz

R452A / R404A / R448A / R449A

FH4532Z-XG1A

Conditions	Frequency	Nominal Cooling Capacity		Sound Power ISO3745 / ISO 3743-1
		Watts	BTU/h	
EN12900_HP / R452A	50 Hz / 60 Hz	6260 / 7561	21348 / 25783	73 dBA
EN12900_HP / R404A	50 Hz / 60 Hz	6248 / 7547	21307 / 25734	73 dBA
EN12900_HP / R448A	50 Hz / 60 Hz	6270 / 7572	21380 / 25821	73 dBA
EN12900_HP / R449A	50 Hz / 60 Hz	6270 / 7572	21380 / 25820	73 dBA

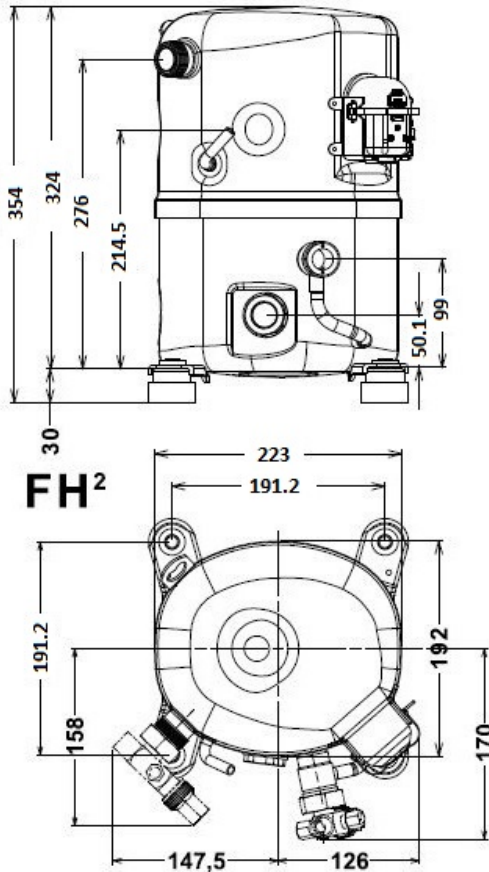

Displacement (cc)	50,6
Net Weight (Kg)	29.0
Oil Quantity (cc)	1140.0
Oil Type	Polyolester
Expansion Device	Capillary_Tube/Expansion_Valve
Cooling	Fan
Main Winding (Ohm)	5.0
Current	
RLA (A)	4.1 4.5
MCC (A)	7.3
LRA (A)	30
Electrical Equipment	TRI
Overload	Interne
Refrigerating connection for	
Suction Tube	22.2 (7/8")
Discharge Tube	12.7 (1/2")
Process Tube	6.35 (1/4")

* EN12900_HP : T°Cond. 50.0°C / T°Evap. 5.0°C / T°Return gas temp.. 20.0°C
T°Subcooling. 0.0K

Certificates :



Note : Tecumseh reserves the right to change information contained in this document without notification.



Tecumseh

FH4532Z-XG	Tension XG : 380-420V 3~ 50Hz / 460V 3~ 60 Hz
-------------------	--

Les performances sont données dans les **conditions EN12900_HP** :
 Condition Dew
 The performance data are in **EN12900_HP conditions** :
 Dew Condition

Gaz aspirés : 20.0 °C
 Sous refroidissement : 0.0 K
 Return gas : 20.0 °C
 Subcooling : 0.0 K

50 Hz R452A											
											N°User-230
4 T condensation	5 T évaporation	(°C)	-25	-20	-15	-10	-5	0	5	10	15
30	1 P frigorifique	(Watt)	2200	2972	3879	4943	6185	7626	9288	11191	13359
	2 P absorbée	(W)	1114	1275	1418	1545	1656	1752	1834	1903	1959
	3 I absorbée	(A)	2.20	2.38	2.55	2.69	2.82	2.94	3.04	3.14	3.24
40	1 P frigorifique	(Watt)		2345	3148	4074	5143	6376	7795	9421	11276
	2 P absorbée	(W)		1337	1525	1696	1849	1986	2107	2213	2305
	3 I absorbée	(A)		2.43	2.67	2.88	3.08	3.25	3.40	3.55	3.68
50	1 P frigorifique	(Watt)			2411	3189	4076	5093	6260	7601	9135
	2 P absorbée	(W)			1598	1817	2017	2200	2365	2515	2648
	3 I absorbée	(A)			2.74	3.04	3.30	3.54	3.76	3.96	4.15
60	1 P frigorifique	(Watt)				2314	3011	3803	4711	5757	6961
	2 P absorbée	(W)				1904	2157	2391	2606	2803	2983
	3 I absorbée	(A)				3.13	3.48	3.81	4.10	4.37	4.62

60 Hz R452A											
											N°User-230
4 T condensation	5 T évaporation	(°C)	-25	-20	-15	-10	-5	0	5	10	15
30	1 P frigorifique	(Watt)	2606	3578	4684	5950	7399	9058	10952	13105	15543
	2 P absorbée	(W)	1306	1520	1716	1890	2040	2165	2262	2329	2363
	3 I absorbée	(A)	2.32	2.54	2.75	2.93	3.11	3.28	3.45	3.61	3.78
40	1 P frigorifique	(Watt)		2809	3824	4959	6240	7691	9338	11206	13320
	2 P absorbée	(W)		1567	1813	2041	2250	2437	2601	2738	2847
	3 I absorbée	(A)		2.59	2.86	3.11	3.34	3.56	3.76	3.96	4.16
50	1 P frigorifique	(Watt)			2902	3882	4968	6186	7561	9118	10882
	2 P absorbée	(W)			1863	2138	2398	2641	2864	3065	3241
	3 I absorbée	(A)			2.90	3.22	3.52	3.80	4.06	4.31	4.55
60	1 P frigorifique	(Watt)				2784	3650	4609	5685	6905	8294
	2 P absorbée	(W)				2187	2491	2782	3057	3314	3552
	3 I absorbée	(A)				3.24	3.62	3.98	4.31	4.62	4.92

1 = cooling capacity 2 = power input 3 = current 4 = condensing temperature 5 = evaporating temperature

Nota : Tecumseh se réserve le droit de modifier les informations contenues dans ce document sans préavis.
Note : Tecumseh reserves the right to change information contained in this document without notification.

© 2023 Tecumseh Products Company
All rights reserved



Tecumseh

FH4532Z-XG	Tension XG : 380-420V 3~ 50Hz / 460V 3~ 60 Hz
-------------------	--

Les performances sont données dans les **conditions EN12900_HP** :
 Condition Dew
 The performance data are in **EN12900_HP conditions** :
 Dew Condition

Gaz aspirés : 20.0 °C
 Sous refroidissement : 0.0 K
 Return gas : 20.0 °C
 Subcooling : 0.0 K

© 2023 Tecumseh Products Company
All rights reserved

50 Hz R404A

N°User-229

4 T condensation	5 T évaporation	(°C)	-25	-20	-15	-10	-5	0	5	10	15
30	1 P frigorifique	(Watt)	2371	3135	4039	5102	6344	7785	9443	11340	13494
	2 P absorbée	(W)	1194	1357	1502	1629	1736	1822	1886	1927	1944
	3 I absorbée	(A)	2.35	2.54	2.70	2.84	2.96	3.05	3.13	3.18	3.21
40	1 P frigorifique	(Watt)	1815	2502	3291	4202	5256	6470	7867	9463	11281
	2 P absorbée	(W)	1225	1427	1613	1783	1935	2068	2180	2272	2341
	3 I absorbée	(A)	2.34	2.59	2.82	3.03	3.22	3.38	3.52	3.64	3.74
50	1 P frigorifique	(Watt)		1861	2529	3282	4140	5122	6248	7539	9012
	2 P absorbée	(W)		1477	1703	1913	2108	2286	2445	2585	2704
	3 I absorbée	(A)		2.62	2.92	3.20	3.45	3.68	3.89	4.07	4.24
60	1 P frigorifique	(Watt)			1783	2370	3025	3767	4617	5593	6716
	2 P absorbée	(W)			1782	2032	2268	2488	2692	2878	3046
	3 I absorbée	(A)			3.00	3.34	3.66	3.96	4.24	4.49	4.71

60 Hz R404A

N°User-229

4 T condensation	5 T évaporation	(°C)	-25	-20	-15	-10	-5	0	5	10	15
30	1 P frigorifique	(Watt)	2809	3775	4878	6142	7590	9247	11135	13278	15701
	2 P absorbée	(W)	1400	1618	1817	1992	2137	2250	2326	2359	2347
	3 I absorbée	(A)	2.49	2.71	2.91	3.09	3.26	3.41	3.54	3.65	3.74
40	1 P frigorifique	(Watt)	2093	2996	3996	5115	6377	7806	9424	11257	13327
	2 P absorbée	(W)	1415	1673	1918	2147	2354	2537	2690	2810	2891
	3 I absorbée	(A)	2.49	2.77	3.02	3.27	3.50	3.71	3.90	4.07	4.22
50	1 P frigorifique	(Watt)		2173	3045	3995	5046	6222	7547	9044	10736
	2 P absorbée	(W)		1708	1984	2252	2507	2744	2960	3150	3310
	3 I absorbée	(A)		2.78	3.09	3.39	3.68	3.95	4.20	4.43	4.65
60	1 P frigorifique	(Watt)			2096	2851	3667	4566	5572	6709	8001
	2 P absorbée	(W)			2041	2332	2619	2896	3159	3404	3627
	3 I absorbée	(A)			3.11	3.47	3.81	4.14	4.45	4.74	5.02

1 = cooling capacity 2 = power input 3 = current 4 = condensing temperature 5 = evaporating temperature

Nota : Tecumseh se réserve le droit de modifier les informations contenues dans ce document sans préavis.

Note : Tecumseh reserves the right to change information contained in this document without notification.



Tecumseh

FH4532Z-XG	Tension XG : 380-420V 3~ 50Hz / 460V 3~ 60 Hz
-------------------	--

Les performances sont données dans les **conditions EN12900_HP** :
 Condition Dew
 The performance data are in **EN12900_HP conditions** :
 Dew Condition

Gaz aspirés : 20.0 °C
 Sous refroidissement : 0.0 K
 Return gas : 20.0 °C
 Subcooling : 0.0 K

© 2023 Tecumseh Products Company
All rights reserved

50 Hz R448A (*)

N°User-232

4 T condensation	5 T évaporation	(°C)	-25	-20	-15	-10	-5	0	5	10	15
30	1 P frigorifique	(Watt)	1958	2685	3556	4594	5822	7263	8942	10880	13102
	2 P absorbée	(W)	1051	1197	1331	1452	1558	1645	1712	1757	1777
	3 I absorbée	(A)	2.07	2.24	2.39	2.53	2.65	2.76	2.84	2.90	2.94
40	1 P frigorifique	(Watt)		2156	2929	3839	4908	6160	7618	9305	11245
	2 P absorbée	(W)		1263	1435	1595	1742	1873	1985	2078	2148
	3 I absorbée	(A)		2.30	2.51	2.71	2.90	3.06	3.21	3.33	3.43
50	1 P frigorifique	(Watt)			2295	3073	3979	5036	6270	7702	9356
	2 P absorbée	(W)			1518	1720	1910	2087	2248	2391	2513
	3 I absorbée	(A)			2.61	2.88	3.13	3.36	3.58	3.77	3.94
60	1 P frigorifique	(Watt)				2329	3068	3927	4932	6104	7468
	2 P absorbée	(W)				1827	2064	2290	2501	2697	2874
	3 I absorbée	(A)				3.01	3.34	3.65	3.94	4.20	4.45

60 Hz R448A (*)

N°User-232

4 T condensation	5 T évaporation	(°C)	-25	-20	-15	-10	-5	0	5	10	15
30	1 P frigorifique	(Watt)	2319	3233	4294	5529	6965	8628	10544	12741	15244
	2 P absorbée	(W)	1232	1427	1611	1776	1918	2032	2111	2151	2145
	3 I absorbée	(A)	2.19	2.39	2.58	2.76	2.93	3.08	3.22	3.33	3.42
40	1 P frigorifique	(Watt)		2582	3558	4673	5956	7431	9127	11069	13283
	2 P absorbée	(W)		1481	1706	1920	2120	2298	2450	2570	2654
	3 I absorbée	(A)		2.45	2.69	2.92	3.15	3.36	3.55	3.72	3.87
50	1 P frigorifique	(Watt)			2764	3741	4849	6118	7572	9239	11145
	2 P absorbée	(W)			1769	2024	2271	2505	2721	2913	3076
	3 I absorbée	(A)			2.76	3.05	3.33	3.61	3.86	4.10	4.32
60	1 P frigorifique	(Watt)				2803	3718	4759	5951	7323	8900
	2 P absorbée	(W)				2097	2384	2665	2935	3190	3423
	3 I absorbée	(A)				3.12	3.47	3.81	4.14	4.45	4.74

1 = cooling capacity 2 = power input 3 = current 4 = condensing temperature 5 = evaporating temperature

(*) Veuillez vous référer strictement aux Recommandations d'Utilisation et Bulletins Marketing Tecumseh du fait de la température de refoulement élevée pour les applications LBP.

(*) Due to very high discharge temperature especially on LBP conditions, please strictly refer to Tecumseh Guidelines & Marketing Bulletin when using this refrigerant.

Nota : Tecumseh se réserve le droit de modifier les informations contenues dans ce document sans préavis.

Note : Tecumseh reserves the right to change information contained in this document without notification.



Tecumseh

FH4532Z-XG	Tension XG : 380-420V 3~ 50Hz / 460V 3~ 60 Hz
-------------------	--

Les performances sont données dans les conditions EN12900_HP :	Gaz aspirés :	20.0 °C
Condition Dew	Sous refroidissement :	0.0 K
The performance data are in EN12900_HP conditions :	Return gas :	20.0 °C
Dew Condition	Subcooling :	0.0 K

50 Hz R449A (*)											
											N°User-231
4 T condensation	5 T évaporation	(°C)	-25	-20	-15	-10	-5	0	5	10	15
30	1 P frigorifique	(Watt)	1958	2685	3556	4594	5822	7263	8942	10880	13102
	2 P absorbée	(W)	1051	1197	1331	1452	1558	1645	1712	1757	1777
	3 I absorbée	(A)	2.07	2.24	2.39	2.53	2.65	2.76	2.84	2.90	2.94
40	1 P frigorifique	(Watt)		2156	2929	3839	4908	6160	7618	9305	11245
	2 P absorbée	(W)		1263	1435	1595	1742	1873	1985	2078	2148
	3 I absorbée	(A)		2.30	2.51	2.71	2.90	3.06	3.21	3.33	3.43
50	1 P frigorifique	(Watt)			2295	3073	3979	5036	6270	7702	9356
	2 P absorbée	(W)			1518	1720	1910	2087	2248	2391	2513
	3 I absorbée	(A)			2.61	2.88	3.13	3.36	3.58	3.77	3.94
60	1 P frigorifique	(Watt)				2329	3068	3927	4932	6104	7468
	2 P absorbée	(W)				1827	2064	2290	2501	2697	2874
	3 I absorbée	(A)				3.01	3.34	3.65	3.94	4.20	4.45

60 Hz R449A (*)											
											N°User-231
4 T condensation	5 T évaporation	(°C)	-25	-20	-15	-10	-5	0	5	10	15
30	1 P frigorifique	(Watt)	2319	3233	4294	5529	6965	8628	10544	12741	15244
	2 P absorbée	(W)	1232	1427	1611	1776	1918	2032	2111	2151	2145
	3 I absorbée	(A)	2.19	2.39	2.58	2.76	2.93	3.08	3.22	3.33	3.42
40	1 P frigorifique	(Watt)		2582	3558	4673	5956	7431	9127	11069	13283
	2 P absorbée	(W)		1481	1706	1920	2120	2298	2450	2570	2654
	3 I absorbée	(A)		2.45	2.69	2.92	3.15	3.36	3.55	3.72	3.87
50	1 P frigorifique	(Watt)			2764	3741	4849	6118	7572	9239	11145
	2 P absorbée	(W)			1769	2024	2271	2505	2721	2913	3076
	3 I absorbée	(A)			2.76	3.05	3.33	3.61	3.86	4.10	4.32
60	1 P frigorifique	(Watt)				2803	3718	4759	5951	7323	8900
	2 P absorbée	(W)				2097	2384	2665	2935	3190	3423
	3 I absorbée	(A)				3.12	3.47	3.81	4.14	4.45	4.74

1 = cooling capacity 2 = power input 3 = current 4 = condensing temperature 5 = evaporating temperature

(*) Veuillez vous référer strictement aux Recommandations d'Utilisation et Bulletins Marketing Tecumseh du fait de la température de reflux élevée pour les applications LBP.
 (*) Due to very high discharge temperature especially on LBP conditions, please strictly refer to Tecumseh Guidelines & Marketing Bulletin when using this refrigerant.

Nota : Tecumseh se réserve le droit de modifier les informations contenues dans ce document sans préavis.
Note : Tecumseh reserves the right to change information contained in this document without notification.

© 2023 Tecumseh Products Company
All rights reserved