



Tecumseh

Compressor Voltage Code : XG

FH4544Z-XG

High Temp. Commercial (HP)

380-420V 3~ 50Hz / 460V 3~ 60 Hz

R452A / R404A / R448A / R449A

FH4544Z-XG1A

Conditions	Frequency	Nominal Cooling Capacity		Sound Power ISO3745 / ISO 3743-1
		Watts	BTU/h	
EN12900_HP / R452A	50 Hz / 60 Hz	9050 / 10715	30860 / 36537	77 dBA
EN12900_HP / R404A	50 Hz / 60 Hz	9032 / 10694	30801 / 36467	77 dBA
EN12900_HP / R448A	50 Hz / 60 Hz	9063 / 10731	30906 / 36592	77 dBA
EN12900_HP / R449A	50 Hz / 60 Hz	9063 / 10731	30906 / 36592	77 dBA

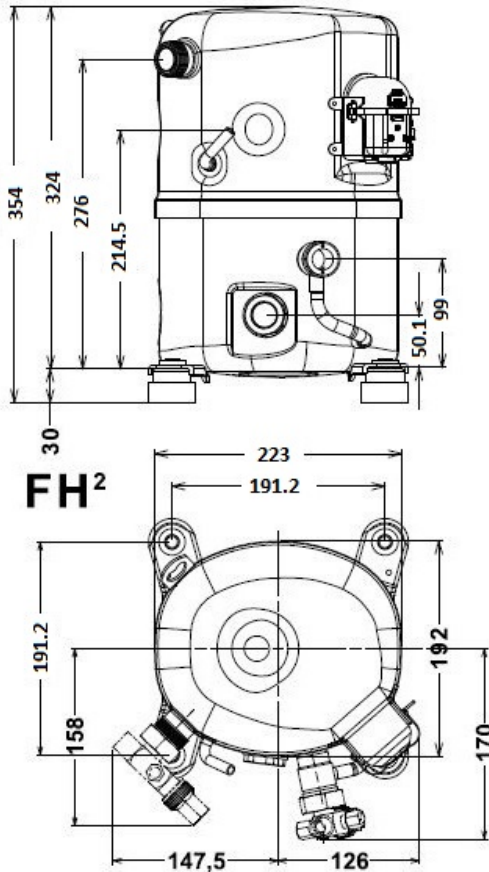

Displacement (cc)	68
Net Weight (Kg)	31.0
Oil Quantity (cc)	1140.0
Oil Type	Polyolester
Expansion Device	Capillary_Tube/Expansion_Valve
Cooling	Fan
Main Winding (Ohm)	4.3
Current	
RLA (A)	6.7 6.6
MCC (A)	12
LRA (A)	42
Electrical Equipment	TRI
Overload	Interne
Refrigerating connection for	
Suction Tube	22.2 (7/8")
Discharge Tube	12.7 (1/2")
Process Tube	6.35 (1/4")

* EN12900_HP : T°Cond. 50.0°C / T°Evap. 5.0°C / T°Return gas temp.. 20.0°C
T°Subcooling. 0.0K

Certificates :



Note : Tecumseh reserves the right to change information contained in this document without notification.



Tecumseh

FH4544Z-XG	Tension XG : 380-420V 3~ 50Hz / 460V 3~ 60 Hz
-------------------	--

Les performances sont données dans les **conditions EN12900_HP** :
 Condition Dew
 The performance data are in **EN12900_HP conditions** :
 Dew Condition

Gaz aspirés : 20.0 °C
 Sous refroidissement : 0.0 K
 Return gas : 20.0 °C
 Subcooling : 0.0 K

© 2023 Tecumseh Products Company
All rights reserved

50 Hz R452A

N°User-304

4 T condensation	5 T évaporation	(°C)	-25	-20	-15	-10	-5	0	5	10	15
30	1 P frigorifique	(Watt)	3306	4474	5792	7291	9001	10953	13179	15708	18573
	2 P absorbée	(W)	1737	2016	2259	2470	2653	2811	2947	3066	3170
	3 I absorbée	(A)	3.78	4.08	4.35	4.59	4.81	5.01	5.20	5.39	5.59
40	1 P frigorifique	(Watt)		3478	4685	6026	7531	9231	11157	13339	15810
	2 P absorbée	(W)		2042	2363	2649	2903	3128	3327	3505	3664
	3 I absorbée	(A)		4.12	4.49	4.83	5.13	5.41	5.67	5.91	6.15
50	1 P frigorifique	(Watt)			3553	4721	6006	7439	9050	10870	12931
	2 P absorbée	(W)			2404	2768	3096	3391	3657	3897	4115
	3 I absorbée	(A)			4.54	4.99	5.40	5.78	6.12	6.44	6.75
60	1 P frigorifique	(Watt)				3417	4467	5617	6898	8341	9977
	2 P absorbée	(W)				2830	3235	3604	3940	4246	4526
	3 I absorbée	(A)				5.01	5.55	6.05	6.50	6.92	7.31

60 Hz R452A

N°User-304

4 T condensation	5 T évaporation	(°C)	-25	-20	-15	-10	-5	0	5	10	15
30	1 P frigorifique	(Watt)	3915	5298	6858	8632	10657	12968	15603	18598	21990
	2 P absorbée	(W)	2050	2378	2665	2915	3130	3317	3478	3617	3740
	3 I absorbée	(A)	3.65	3.94	4.20	4.43	4.64	4.83	5.02	5.21	5.39
40	1 P frigorifique	(Watt)		4117	5547	7135	8917	10929	13209	15794	18718
	2 P absorbée	(W)		2409	2789	3126	3425	3690	3926	4135	4323
	3 I absorbée	(A)		3.98	4.34	4.66	4.96	5.22	5.47	5.71	5.94
50	1 P frigorifique	(Watt)			4207	5590	7111	8807	10715	12870	15310
	2 P absorbée	(W)			2837	3266	3653	4001	4315	4598	4855
	3 I absorbée	(A)			4.38	4.82	5.22	5.58	5.91	6.22	6.51
60	1 P frigorifique	(Watt)				4046	5289	6650	8167	9875	11812
	2 P absorbée	(W)				3339	3817	4252	4648	5010	5340
	3 I absorbée	(A)				4.84	5.36	5.84	6.28	6.68	7.06

1 = cooling capacity 2 = power input 3 = current 4 = condensing temperature 5 = evaporating temperature

Nota : Tecumseh se réserve le droit de modifier les informations contenues dans ce document sans préavis.

Note : Tecumseh reserves the right to change information contained in this document without notification.



Tecumseh

FH4544Z-XG	Tension XG : 380-420V 3~ 50Hz / 460V 3~ 60 Hz
-------------------	--

Les performances sont données dans les **conditions EN12900_HP** :
 Condition Dew
 The performance data are in **EN12900_HP conditions** :
 Dew Condition

Gaz aspirés : 20.0 °C
 Sous refroidissement : 0.0 K
 Return gas : 20.0 °C
 Subcooling : 0.0 K

50 Hz R404A											
											N°User-303
4 T condensation	5 T évaporation	(°C)	-25	-20	-15	-10	-5	0	5	10	15
30	1 P frigorifique	(Watt)	3563	4720	6031	7526	9233	11181	13399	15917	18762
	2 P absorbée	(W)	1862	2145	2392	2604	2781	2923	3031	3105	3146
	3 I absorbée	(A)	4.06	4.35	4.61	4.84	5.04	5.21	5.35	5.46	5.54
40	1 P frigorifique	(Watt)	2628	3710	4897	6216	7697	9368	11260	13400	15817
	2 P absorbée	(W)	1825	2179	2499	2785	3038	3257	3444	3598	3720
	3 I absorbée	(A)	4.01	4.40	4.75	5.08	5.37	5.64	5.87	6.07	6.24
50	1 P frigorifique	(Watt)		2681	3729	4859	6100	7482	9032	10781	12757
	2 P absorbée	(W)		2178	2562	2915	3235	3523	3780	4006	4202
	3 I absorbée	(A)		4.38	4.83	5.25	5.64	6.00	6.33	6.63	6.89
60	1 P frigorifique	(Watt)			2572	3499	4487	5565	6761	8105	9625
	2 P absorbée	(W)			2612	3022	3401	3751	4070	4360	4622
	3 I absorbée	(A)			4.84	5.36	5.84	6.30	6.72	7.11	7.47

60 Hz R404A											
											N°User-303
4 T condensation	5 T évaporation	(°C)	-25	-20	-15	-10	-5	0	5	10	15
30	1 P frigorifique	(Watt)	4219	5588	7141	8910	10931	13238	15864	18845	22214
	2 P absorbée	(W)	2197	2531	2823	3073	3281	3449	3576	3664	3712
	3 I absorbée	(A)	3.91	4.20	4.45	4.67	4.86	5.03	5.16	5.27	5.35
40	1 P frigorifique	(Watt)	3112	4393	5798	7359	9113	11092	13331	15865	18727
	2 P absorbée	(W)	2153	2571	2949	3286	3584	3843	4063	4245	4389
	3 I absorbée	(A)	3.87	4.24	4.59	4.90	5.19	5.44	5.67	5.86	6.03
50	1 P frigorifique	(Watt)		3175	4415	5753	7223	8858	10694	12765	15104
	2 P absorbée	(W)		2569	3023	3439	3817	4157	4460	4727	4958
	3 I absorbée	(A)		4.23	4.66	5.07	5.45	5.79	6.11	6.40	6.65
60	1 P frigorifique	(Watt)			3045	4143	5313	6588	8005	9596	11396
	2 P absorbée	(W)			3082	3566	4013	4425	4802	5145	5453
	3 I absorbée	(A)			4.67	5.17	5.64	6.08	6.48	6.86	7.21

1 = cooling capacity 2 = power input 3 = current 4 = condensing temperature 5 = evaporating temperature

Nota : Tecumseh se réserve le droit de modifier les informations contenues dans ce document sans préavis.

Note : Tecumseh reserves the right to change information contained in this document without notification.

© 2023 Tecumseh Products Company
All rights reserved



Tecumseh

FH4544Z-XG	Tension XG : 380-420V 3~ 50Hz / 460V 3~ 60 Hz
-------------------	--

Les performances sont données dans les conditions EN12900_HP :	Gaz aspirés :	20.0 °C
Condition Dew	Sous refroidissement :	0.0 K
The performance data are in EN12900_HP conditions :	Return gas :	20.0 °C
Dew Condition	Subcooling :	0.0 K

50 Hz R448A (*)											
											N°User-328
4 T condensation	5 T évaporation	(°C)	-25	-20	-15	-10	-5	0	5	10	15
30	1 P frigorifique	(Watt)	2943	4043	5310	6776	8473	10433	12688	15272	18216
	2 P absorbée	(W)	1638	1892	2120	2322	2495	2639	2751	2831	2876
	3 I absorbée	(A)	3.57	3.83	4.08	4.31	4.52	4.70	4.86	4.98	5.07
40	1 P frigorifique	(Watt)		3197	4359	5679	7188	8919	10904	13175	15766
	2 P absorbée	(W)		1930	2223	2492	2735	2950	3136	3291	3414
	3 I absorbée	(A)		3.89	4.23	4.54	4.84	5.10	5.35	5.55	5.73
50	1 P frigorifique	(Watt)			3383	4549	5863	7357	9063	11015	13244
	2 P absorbée	(W)			2284	2620	2931	3217	3475	3705	3905
	3 I absorbée	(A)			4.31	4.72	5.11	5.48	5.82	6.13	6.40
60	1 P frigorifique	(Watt)				3440	4551	5800	7220	8844	10704
	2 P absorbée	(W)				2717	3096	3451	3782	4086	4362
	3 I absorbée	(A)				4.81	5.32	5.79	6.24	6.66	7.05

60 Hz R448A (*)											
											N°User-328
4 T condensation	5 T évaporation	(°C)	-25	-20	-15	-10	-5	0	5	10	15
30	1 P frigorifique	(Watt)	3484	4787	6287	8023	10031	12352	15022	18081	21567
	2 P absorbée	(W)	1933	2232	2502	2740	2944	3114	3246	3340	3393
	3 I absorbée	(A)	3.44	3.70	3.94	4.16	4.36	4.54	4.69	4.81	4.89
40	1 P frigorifique	(Watt)		3785	5161	6723	8510	10559	12910	15599	18666
	2 P absorbée	(W)		2277	2623	2940	3227	3480	3700	3883	4028
	3 I absorbée	(A)		3.76	4.08	4.38	4.67	4.93	5.16	5.36	5.53
50	1 P frigorifique	(Watt)			4006	5386	6941	8710	10731	13041	15680
	2 P absorbée	(W)			2695	3091	3458	3795	4100	4372	4608
	3 I absorbée	(A)			4.16	4.56	4.94	5.29	5.62	5.92	6.18
60	1 P frigorifique	(Watt)				4073	5388	6867	8549	10471	12673
	2 P absorbée	(W)				3206	3653	4072	4462	4821	5146
	3 I absorbée	(A)				4.65	5.13	5.59	6.03	6.43	6.80

1 = cooling capacity 2 = power input 3 = current 4 = condensing temperature 5 = evaporating temperature

(*) Veuillez vous référer strictement aux Recommandations d'Utilisation et Bulletins Marketing Tecumseh du fait de la température de reflux élevée pour les applications LBP.
 (*) Due to very high discharge temperature especially on LBP conditions, please strictly refer to Tecumseh Guidelines & Marketing Bulletin when using this refrigerant.

Nota : Tecumseh se réserve le droit de modifier les informations contenues dans ce document sans préavis.

Note : Tecumseh reserves the right to change information contained in this document without notification.

© 2023 Tecumseh Products Company
All rights reserved



Tecumseh

FH4544Z-XG	Tension XG : 380-420V 3~ 50Hz / 460V 3~ 60 Hz
-------------------	--

Les performances sont données dans les conditions EN12900_HP :	Gaz aspirés :	20.0 °C
Condition Dew	Sous refroidissement :	0.0 K
The performance data are in EN12900_HP conditions :	Return gas :	20.0 °C
Dew Condition	Subcooling :	0.0 K

50 Hz R449A (*)											
											N°User-305
4 T condensation	5 T évaporation	(°C)	-25	-20	-15	-10	-5	0	5	10	15
30	1 P frigorifique	(Watt)	2943	4043	5310	6776	8473	10433	12688	15272	18216
	2 P absorbée	(W)	1638	1892	2120	2322	2495	2639	2751	2831	2876
	3 I absorbée	(A)	3.57	3.83	4.08	4.31	4.52	4.70	4.86	4.98	5.07
40	1 P frigorifique	(Watt)		3197	4359	5679	7188	8919	10904	13175	15766
	2 P absorbée	(W)		1930	2223	2492	2735	2950	3136	3291	3414
	3 I absorbée	(A)		3.89	4.23	4.54	4.84	5.10	5.35	5.55	5.73
50	1 P frigorifique	(Watt)			3383	4549	5863	7357	9063	11015	13244
	2 P absorbée	(W)			2284	2620	2931	3217	3475	3705	3905
	3 I absorbée	(A)			4.31	4.72	5.11	5.48	5.82	6.13	6.40
60	1 P frigorifique	(Watt)				3440	4551	5800	7220	8844	10704
	2 P absorbée	(W)				2717	3096	3451	3782	4086	4362
	3 I absorbée	(A)				4.81	5.32	5.79	6.24	6.66	7.05

60 Hz R449A (*)											
											N°User-305
4 T condensation	5 T évaporation	(°C)	-25	-20	-15	-10	-5	0	5	10	15
30	1 P frigorifique	(Watt)	3484	4787	6287	8023	10031	12352	15022	18081	21567
	2 P absorbée	(W)	1933	2232	2502	2740	2944	3114	3246	3340	3393
	3 I absorbée	(A)	3.44	3.70	3.94	4.16	4.36	4.54	4.69	4.81	4.89
40	1 P frigorifique	(Watt)		3785	5161	6723	8510	10559	12910	15599	18666
	2 P absorbée	(W)		2277	2623	2940	3227	3480	3700	3883	4028
	3 I absorbée	(A)		3.76	4.08	4.38	4.67	4.93	5.16	5.36	5.53
50	1 P frigorifique	(Watt)			4006	5386	6941	8710	10731	13041	15680
	2 P absorbée	(W)			2695	3091	3458	3795	4100	4372	4608
	3 I absorbée	(A)			4.16	4.56	4.94	5.29	5.62	5.92	6.18
60	1 P frigorifique	(Watt)				4073	5388	6867	8549	10471	12673
	2 P absorbée	(W)				3206	3653	4072	4462	4821	5146
	3 I absorbée	(A)				4.65	5.13	5.59	6.03	6.43	6.80

1 = cooling capacity 2 = power input 3 = current 4 = condensing temperature 5 = evaporating temperature

(*) Veuillez vous référer strictement aux Recommandations d'Utilisation et Bulletins Marketing Tecumseh du fait de la température de refoulement élevée pour les applications LBP.
 (*) Due to very high discharge temperature especially on LBP conditions, please strictly refer to Tecumseh Guidelines & Marketing Bulletin when using this refrigerant.

Nota : Tecumseh se réserve le droit de modifier les informations contenues dans ce document sans préavis.

Note : Tecumseh reserves the right to change information contained in this document without notification.

© 2023 Tecumseh Products Company
All rights reserved