



Compressor
Voltage Code : FZ

RK5512Y

Air Conditioning & Heating (CA)

220 - 240V 1~ 50 Hz

R134a

RKA5512YFZ

Conditions	Frequency	Nominal Cooling Capacity		Sound Power ISO3745 / ISO 3743-1
		Watts	BTU/h	
EN12900 / R134a	50 Hz	2406	8205	67 dBA

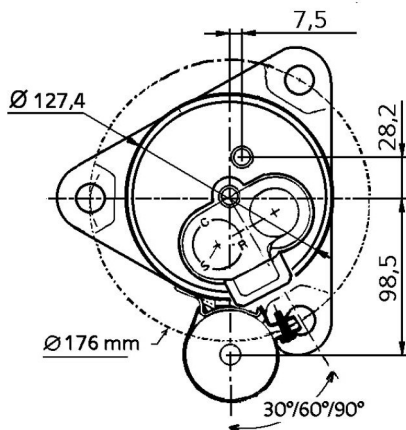
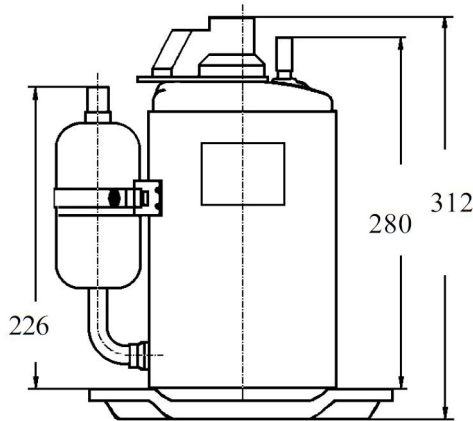

* EN12900 : T°Cond. 50.0°C / T°Evap. 5.0°C / T°Superheat. 10.0°C
T°Subcooling. 0.0K

Certificates :



Displacement (cc)	24,4
Net Weight (Kg)	13.5
Oil Quantity (cc)	444.0
Oil Type	Polyvinylether
Expansion Device	Capillary_Tube
Cooling	Fan
Main Winding (Ohm)	2.6
Start Winding (Ohm)	4.3
Current	
RLA (A)	4
MCC (A)	6
LRA (A)	24
Electrical Equipment	CSR,PSC
Overload	MST20ALZ
Time Check	2.8s - 5.2s / 22.5 A
Open Temp	120° C
Close Temp	61° C
Optional	T0615
Start Capacitor	21 µF / 330 V
Run Capacitor	25 µF / 400 V
Potential Relay	RVA2C**
Pick Up	140/153V
Drop Out	40/90V
Optional	3ARR3*3AL*
Refrigerating connection for	
Suction Tube	15.9 (5/8")
Discharge Tube	7.9 (5/16")

Note : Tecumseh reserves the right to change information contained in this document without notification.



Tecumseh

RK5512Y	Tension FZ : 220 - 240V 1~ 50 Hz
----------------	---

Les performances sont données dans les conditions EN12900 :	Surchauffe :	10.0 K
Condition Dew	Sous refroidissement :	0.0 K
The performance data are in EN12900 conditions :	Superheat :	10.0 K
Dew Condition	Subcooling :	0.0 K

50 Hz R134a

N°313SH-F

4 T condensation	5 T évaporation	(°C)	-25	-20	-15	-10	-5	0	5	10	15
40	1 P frigorifique	(Watt)				1685	2022	2441	2943	3529	4197
	2 P absorbée	(W)				692	713	730	743	753	759
	3 I absorbée	(A)				3.23	3.35	3.46	3.55	3.62	3.69
50	1 P frigorifique	(Watt)					1596	1967	2406	2915	3494
	2 P absorbée	(W)					746	779	810	838	863
	3 I absorbée	(A)					3.43	3.59	3.74	3.88	4.02
60	1 P frigorifique	(Watt)						1564	1934	2360	2842
	2 P absorbée	(W)						828	875	922	967
	3 I absorbée	(A)						3.73	3.94	4.15	4.36

© 2023 Tecumseh Products Company
All rights reserved

1 = cooling capacity 2 = power input 3 = current 4 = condensing temperature 5 = evaporating temperature

Nota : Tecumseh se réserve le droit de modifier les informations contenues dans ce document sans préavis.

Note : Tecumseh reserves the right to change information contained in this document without notification.