



Compressor  
Voltage Code : TZ

**TAG4528Y**

High Temp. Commercial (HP)

400V 3~ 50Hz / 440V 3~ 60 Hz

R134a

AGB4528YTZ

Conditions	Frequency	Nominal Cooling Capacity		Sound Power ISO3745 / ISO 3743-1
		Watts	BTU/h	
EN12900_HP / R134a	50 Hz / 60 Hz	6106 / 7180	20820 / 24484	76 dBA

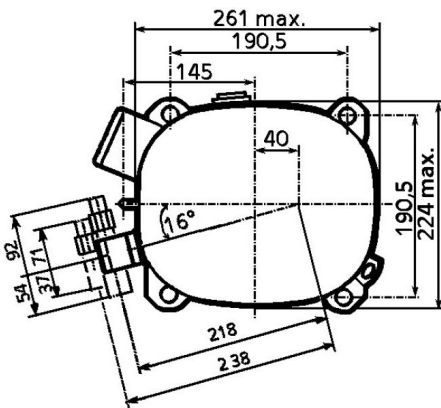
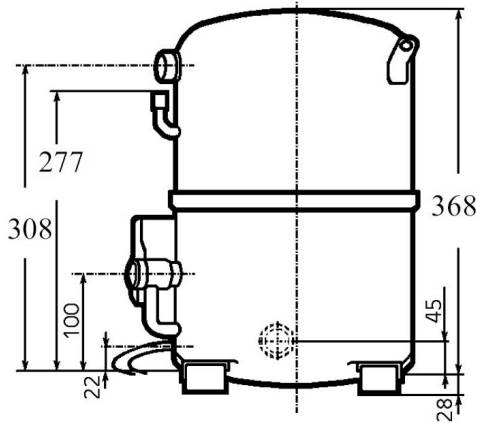

<b>Displacement (cc)</b>	90,2
<b>Net Weight (Kg)</b>	44.0
<b>Oil Quantity (cc)</b>	1760.0
<b>Oil Type</b>	Polyolester
<b>Expansion Device</b>	Capillary_Tube/Expansion_Valve
<b>Cooling</b>	Fan
<b>Main Winding (Ohm)</b>	4.6
<b>Current</b>	
RLA (A)	4.4   4.4
MCC (A)	10   8.6
LRA (A)	42   43
<b>Electrical Equipment</b>	TRI
<b>Overload</b>	Interne
<b>Refrigerating connection for</b>	
Suction Tube	22.2 (7/8")
Discharge Tube	15.9 (5/8")
Process Tube	6.35 (1/4")

\* EN12900\_HP : T°Cond. 50.0°C / T°Evap. 5.0°C / T°Return gas temp.. 20.0°C  
T°Subcooling. 0.0K

Certificates :



Note : Tecumseh reserves the right to change information contained in this document without notification.



**Tecumseh**

<b>TAG4528Y</b>	<b>Tension TZ : 400V 3~ 50Hz / 440V 3~ 60 Hz</b>
-----------------	--

Les performances sont données dans les <b>conditions EN12900_HP</b> :	Gaz aspirés :	20.0 °C
Condition Dew	Sous refroidissement :	0.0 K
The performance data are in <b>EN12900_HP conditions</b> :	Return gas :	20.0 °C
Dew Condition	Subcooling :	0.0 K

© 2023 Tecumseh Products Company  
All rights reserved

### 50 Hz R134a

**N°217CU-T**

4   T condensation	5   T évaporation	(°C)	-25	-20	-15	-10	-5	0	5	10	15
<b>30</b>	1   P frigorifique	(Watt)	879	1484	2366	3516	4920	6569	8450	10553	12866
	2   P absorbée	(W)	656	929	1174	1390	1577	1735	1864	1965	2037
	3   I absorbée	(A)	2.51	2.76	2.98	3.20	3.39	3.57	3.73	3.87	3.99
<b>40</b>	1   P frigorifique	(Watt)	734	1219	1963	2953	4176	5621	7276	9129	11168
	2   P absorbée	(W)	643	921	1182	1425	1650	1857	2047	2219	2373
	3   I absorbée	(A)	2.50	2.75	2.99	3.23	3.47	3.71	3.95	4.19	4.42
<b>50</b>	1   P frigorifique	(Watt)		953	1557	2388	3432	4675	6106	7710	9476
	2   P absorbée	(W)		914	1190	1460	1723	1980	2230	2473	2710
	3   I absorbée	(A)		2.74	3.00	3.27	3.56	3.86	4.18	4.51	4.85
<b>60</b>	1   P frigorifique	(Watt)			1150	1822	2687	3730	4938	6297	7792
	2   P absorbée	(W)			1199	1495	1797	2103	2413	2728	3047
	3   I absorbée	(A)			3.01	3.31	3.64	4.01	4.40	4.83	5.28

### 60 Hz R134a

**N°217CU-T**

4   T condensation	5   T évaporation	(°C)	-25	-20	-15	-10	-5	0	5	10	15
<b>30</b>	1   P frigorifique	(Watt)	924	1690	2768	4145	5807	7742	9938	12381	15060
	2   P absorbée	(W)	680	1029	1346	1629	1880	2098	2283	2435	2555
	3   I absorbée	(A)	2.27	2.53	2.80	3.06	3.32	3.58	3.83	4.09	4.35
<b>40</b>	1   P frigorifique	(Watt)	769	1387	2296	3481	4929	6626	8557	10711	13073
	2   P absorbée	(W)	671	1022	1355	1670	1967	2246	2507	2750	2975
	3   I absorbée	(A)	2.28	2.53	2.80	3.09	3.40	3.72	4.07	4.43	4.81
<b>50</b>	1   P frigorifique	(Watt)		1082	1822	2816	4050	5510	7180	9046	11093
	2   P absorbée	(W)		1015	1365	1711	2054	2394	2731	3065	3395
	3   I absorbée	(A)		2.53	2.81	3.13	3.48	3.87	4.30	4.76	5.27
<b>60</b>	1   P frigorifique	(Watt)			1345	2149	3172	4396	5807	7388	9124
	2   P absorbée	(W)			1374	1752	2142	2543	2956	3380	3815
	3   I absorbée	(A)			2.82	3.16	3.56	4.02	4.53	5.10	5.73

1 = cooling capacity 2 = power input 3 = current 4 = condensing temperature 5 = evaporating temperature

**Nota : Tecumseh se réserve le droit de modifier les informations contenues dans ce document sans préavis.**

**Note : Tecumseh reserves the right to change information contained in this document without notification.**