



Compressor
Voltage Code : TZ

TAJ4492Y-TZ

High Temp. Commercial (HP)

400V 3~ 50Hz / 440V 3~ 60 Hz

R134a

AJ4492Y-TZ1C

Conditions	Frequency	Nominal Cooling Capacity		Sound Power ISO3745 / ISO 3743-1
		Watts	BTU/h	
EN12900_HP / R134a	50 Hz / 60 Hz	2175 / 2451	7417 / 8358	58 dBA

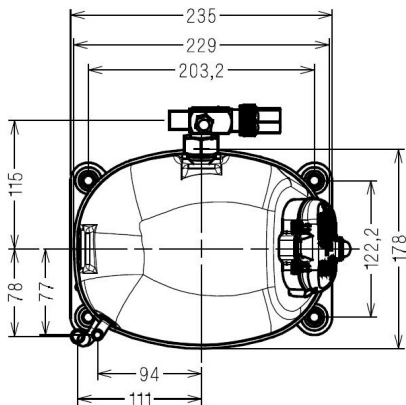
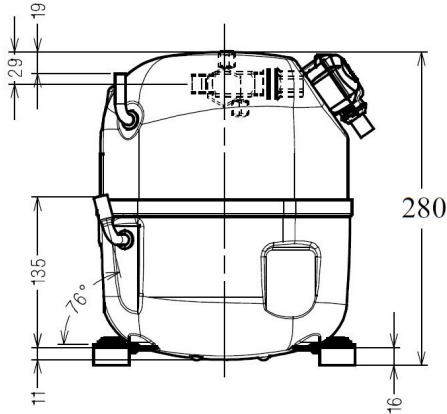

Displacement (cc)	25,95
Net Weight (Kg)	19.0
Oil Quantity (cc)	475.0
Oil Type	Polyolester
Expansion Device	Capillary_Tube/Expansion_Valve
Cooling	Fan
Main Winding (Ohm)	16.9
Current	
RLA (A)	1.8 1.9
MCC (A)	3.5 3.7
LRA (A)	12.6 12.8
Electrical Equipment	TRI
Overload	Interne
Refrigerating connection for	
Suction Tube	12.7 (1/2")
Discharge Tube	7.9 (5/16")
Process Tube	6.35 (1/4")

* EN12900_HP : T°Cond. 50.0°C / T°Evap. 5.0°C / T°Return gas temp.. 20.0°C
T°Subcooling. 0.0K

Certificates :



Note : Tecumseh reserves the right to change information contained in this document without notification.



Tecumseh

TAJ4492Y-TZ	Tension TZ : 400V 3~ 50Hz / 440V 3~ 60 Hz
--------------------	--

Les performances sont données dans les **conditions EN12900_HP** :
 Condition Dew
 The performance data are in **EN12900_HP conditions** :
 Dew Condition

Gaz aspirés : 20.0 °C
 Sous refroidissement : 0.0 K
 Return gas : 20.0 °C
 Subcooling : 0.0 K

50 Hz R134a											
N°214LU-TZ											
4 T condensation	5 T évaporation	(°C)	-25	-20	-15	-10	-5	0	5	10	15
30	1 P frigorifique	(Watt)	615	856	1143	1487	1898	2387	2964	3640	4425
	2 P absorbée	(W)	385	445	500	551	599	644	688	730	772
	3 I absorbée	(A)	1.16	1.20	1.25	1.29	1.35	1.40	1.45	1.50	1.54
40	1 P frigorifique	(Watt)	447	684	954	1267	1632	2062	2565	3153	3837
	2 P absorbée	(W)	370	452	527	596	659	718	772	823	872
	3 I absorbée	(A)	1.15	1.21	1.27	1.34	1.41	1.48	1.54	1.61	1.67
50	1 P frigorifique	(Watt)		484	744	1033	1361	1738	2175	2683	3272
	2 P absorbée	(W)		427	529	623	709	788	861	928	991
	3 I absorbée	(A)		1.19	1.28	1.37	1.47	1.56	1.65	1.74	1.83
60	1 P frigorifique	(Watt)			505	777	1074	1407	1785	2220	2722
	2 P absorbée	(W)			489	614	730	837	935	1026	1110
	3 I absorbée	(A)			1.23	1.36	1.49	1.62	1.75	1.87	1.99

60 Hz R134a											
N°214LU-TZ											
4 T condensation	5 T évaporation	(°C)	-25	-20	-15	-10	-5	0	5	10	15
30	1 P frigorifique	(Watt)	644	955	1307	1710	2173	2705	3317	4016	4814
	2 P absorbée	(W)	429	510	581	644	703	759	818	881	951
	3 I absorbée	(A)	1.10	1.18	1.26	1.32	1.39	1.45	1.52	1.60	1.68
40	1 P frigorifique	(Watt)	403	711	1050	1428	1857	2344	2900	3534	4256
	2 P absorbée	(W)	386	500	599	688	768	843	916	990	1068
	3 I absorbée	(A)	1.02	1.15	1.27	1.37	1.47	1.56	1.65	1.75	1.84
50	1 P frigorifique	(Watt)		447	769	1121	1513	1953	2451	3017	3659
	2 P absorbée	(W)		444	580	701	811	912	1007	1100	1193
	3 I absorbée	(A)		1.04	1.21	1.37	1.51	1.65	1.77	1.89	2.01
60	1 P frigorifique	(Watt)			482	805	1157	1547	1985	2480	3041
	2 P absorbée	(W)			513	675	821	956	1081	1201	1317
	3 I absorbée	(A)			1.11	1.33	1.53	1.71	1.88	2.04	2.19

1 = cooling capacity 2 = power input 3 = current 4 = condensing temperature 5 = evaporating temperature

Nota : Tecumseh se réserve le droit de modifier les informations contenues dans ce document sans préavis.

Note : Tecumseh reserves the right to change information contained in this document without notification.

© 2023 Tecumseh Products Company
All rights reserved