

ESY 1~

User Manual



Specialized Vac stepless Controllers

for

**single-phase Asynchronous Motors
on Axial & Centrifugal Fans**

ON

**Ventilated Heat Exchangers
Drycoolers & Air Cooled Condensers**

S.EL.PRO.®
sistemi elettronici professionali

FAN speed Control Solutions

Global
3
YEAR
Warranty



WARNING ! HIGH LEAKAGE CURRENT First connect to Earth !
DO NOT touch the electrical parts of the circuit when the power supply is connected under any circumstances



Safety Warnings

- We disclaim all responsibility for accident, loss or damage caused by the use of these appliances. These must be correctly installed by qualified personnel in conformity with their intended use and, whenever needed, must undergo correct maintenance which should be carried out while ensuring the safety of people, domestic animals and goods.
- Do **NOT** tamper with or disassemble the regulator internal components; doing so will **INVALIDATE THE GUARANTEE** and may cause unnecessary damage. The regulator does not contain components that can be repaired by the user.
- The regulator must be **SUITABLY AND EFFECTIVELY EARTHED** by the installer, under his own responsibility, according to the standards in force; earthing is essential for the EMC filter to operate correctly.

Precautions

- When receiving the goods, check that the packing is intact; in the event of any damage due to transportation, notify the forwarding agent according to legal requirements.
- The regulator must be installed by qualified personnel who will connect the electric supply with **GROUND CONNECTION**, attach the cables in their permanent positions and commission the plant.
- Incorrect installation of the ESY100 voltage regulator may cause damage to objects or people, so ensure the instructions in this manual and all required security measures are read and followed carefully.
- Before supplying power to the unit, make sure that the regulator is correctly connected to the power supply and to earth. Follow the instructions in this manual exactly and observe all safety measures in force.
- The user must be protected from the electric supply and the motor must be protected from possible overloads in compliance with the standards in force. **DO NOT** touch any electrical parts of the circuit when the power supply is connected under any circumstances.
- If the mains supply is "disturbed", which may be due to other electrical power components causing irregularities in the supply (power contactors), it is recommended that supplementary SINGLE phase 'SURGE ARRESTER' filters are installed directly on the regulator supply.
- Avoid repeatedly connecting and disconnecting the power supply to the regulator; a constant supply keeps the regulator at working temperature and eliminates problems caused by condensate inside the protection case.
- Install the regulator out of direct sunlight, in order to protect the case from overheating. The appliance can operate at environmental temperatures up to 50°C. Do **NOT** install it where this temperature may exceed, otherwise the integrity of the regulator will be compromised, since the controller may make the user appliance operate at full load (**100%**) with all consequent effects.
- The equipment must be placed vertically, in order to encourage heat dissipation and to ensure sufficient air circulation in a free space measuring at least **150 mm** above and below the regulator. If several regulators are to be grouped together on a single electric board, please provide forced air circulation with a fan or with a sufficiently powerful cooling unit.

Description of symbols in use in the present manual



! Attention !



Important information



Compliance with:
CE mark –Electromagnetic Emissions – Low Voltage Directives

Factory Default

The highlighted characteristics are Factory STANDARD settings



PRODUCT end of life – WEEE directive

Contents:

Safety Warnings	Errore. Il segnalibro non è definito.
Precautions.....	1
Contents	2
1.. EC DIRECTIVES & TECHNICAL STANDARDS	3
2... Mechanical Dimensions ESY-1	3
3... OPERATING MODES AND APPLICATIONS.....	4
4... TECHNICAL CHARACTERISTICS ESY-1	5
5... ELECTRICAL CONNECTIONS.....	Errore. Il segnalibro non è definito.
5.1. Power Supply Connection (Terminal Block M1).....	7
6... SIGNAL CONNECTIONS for the 4 CONFIGURATIONS (ALL-in-ONE).....	8
6.1. OM CONFIGURATION (STANDARD SELPRO)	8
6.2. OX Configuration (on request).....	8
6.3. OV Configuration (on request).....	9
6.4. OB Configuration (on request).....	9
7... Electrical connection for Slave Module/s	10
7.1. Connection of SLAVE modules, SV series (0-10Vdc power units).....	10
7.2. Connecting ESY-1 to SLAVE-SV / 0-10 Vdc modules (Three-/Single-phase connection).....	10
7.3. Connection of SLAVE modules, SP series (PWM power units)	11
7.4. Connecting SLAVE-SP modules – Power supply in phase with the Master unit (network synchronization).....	11
8... ESY-1: CONTROL & POWER CARD IN DETAIL, ALL-in-ONE version	12
8.1. ESY-1: CONTROL & POWER CARD IN DETAIL, SLAVE-ONE versions.....	12
8.2. LED signals	13
8.3. Configuration and selection JUMPERS.....	13
9... Set-up of operating LIMITS and PARAMETERS.....	14
9.1. Available regulations in the standard ESY-1 version (ALL-in-ONE).....	14
9.2. How to set up the operating limits for the ALL-in-ONE version).....	14
9.3. How to set up the operating limits for SLAVE-ONE modules (only SLAVE-SV version).....	15
9.4. Table showing the scale of values for setting up the ESY-1 regulation VAC Limits.....	15
9.5. Tables for the Set-Point selection:	16
9.5.1. Set-Point values, range 0-15 bar (Transducer 4-20 mA).....	16
9.5.2. Set-Point values, range 0-15 bar (Transducer 4-20 mA).....	16
9.5.3. Set Point values, range 0-25 bar (Transducer 4-20 mA).....	17
9.5.4. Set Point values, range 0-30 bar (Transducer 4-20 mA).....	17
9.5.5. Set-Point values, range 0-45 bar (Transducer 4-20 mA).....	18
9.5.6. Set Point values, range 0-30 bar (Transducer 0,5-4,5 Vdc)	18
9.5.7. Set-Point values, range 10°C to 60°C (NTC probe 10kohm@25°C).....	19
9.6. Regulation with Double SET-Point (optional).....	19
10. Function diagrams & Operating parameters in MASTER & SLAVE modes	20
10.1. ESY-1 MASTER mode.....	20
10.2. ESY-1 SLAVE mode	20
11. ACCESSORIES.....	21
11.1. Manual Remote Control Units.....	Errore. Il segnalibro non è definito.
11.2. Pressure Transducer for 4-20 mA & 0-5 V.....	22
11.3. Temperature Probe NTC (10 kohm@25°C).....	Errore. Il segnalibro non è definito.
11.4. RGF-MEI(4) / UNIVERSAL input Expansion Module.....	Errore. Il segnalibro non è definito.

PRODUCT end of life

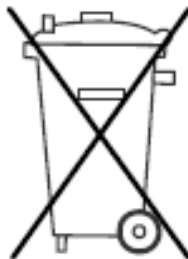

The device must be disposed of separately, according to the local authority advice.

1. EC DIRECTIVES & TECHNICAL STANDARDS

This series has been designed and manufactured for use in industrial environments, and complies therefore with the following European Directives:

- Machine Directive 98/37 CE and following amendments
- Low Voltage Directive (LVD) 2006/95/EC
- EMC Directive 2004/108/EC

Thanks to its advanced technical solutions, the **ESY100** series has obtained the **CE** mark in compliance with the EMC (Electromagnetic Compatibility) directive **2004/108/EC** also in household environment.

The essential requirements of the directive are satisfied by the conformity to the “**generic standards**” for industrial environments.

Directive	Standard Code	Description
98/37/CE	EN 60204-1	Safety of machinery. Electrical equipment of machines.
73/23/CE	EN60204-1	Safety of machinery. Electrical equipment of machines.
	EN 50178	Electronic equipment for use in power installations.
89/336/CE	EN 61000-3	Adjustable speed electrical power drive systems. Part 3: EMC product standard including specific test methods.



All products have been tested in accordance with the procedures and test conditions laid down in the standards specified in the product technical file.

Since these products are destined to be used not only as “stand alone” systems, but also as components of other machines or plants, all compatibility tests to the standards have been performed under typical conditions of use.

In particular, the tests have been performed in a system consisting of a voltage controller RGM300, a control cable and relative commands, a supply cable, a motor cable and a group of fans with an equivalent power to the value of the nominal current of the controller, set to operate within specific VAC values for the single-phase regulation according to EMC requirements.



! WARNING !



The final specifications of the system or plant, in compliance with the EMC directive, are in any case the responsibility of the installer, who must put the system into operation carefully, according to the rules in force and following the information provided by the present manual.

2. Mechanical Dimensions ESY-1

Model	A	B	C	D	E	F	Kg.	Ø fastening holes
ESY 08	195	162	97	195	145	162	1.4 Kg	Ø 5
ESY 12	195	162	97	195	145	162	1.5 Kg	Ø 5
ESY 16	240	152	115	195	93	210	1.7 Kg	Ø 5
ESY 20	240	152	115	195	93	210	1.8 Kg	Ø 5

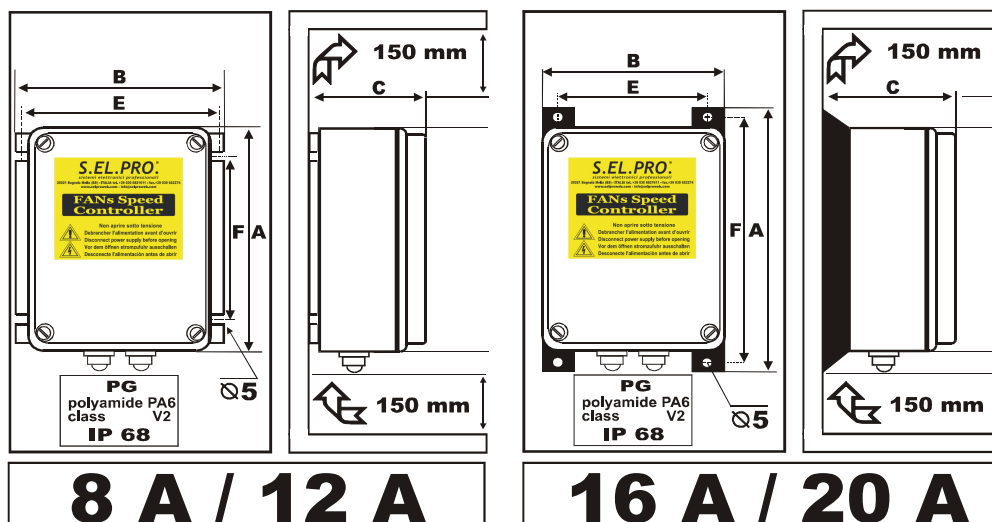

3. OPERATING MODES AND APPLICATIONS

The **ESY1** devices are electronic analog regulators of single-phase AC voltage, which use the phase-cutting principle (Triac) in order to vary the output active voltage applied to a resistive or inductive load.

When connected to asynchronous high-slip electric motors of fans or pumps, they control their rotational speed in order to maintain the key parameter within desired values. On this purpose they have been projected and specialized for control applications on Air Cooled Heat Exchangers, used in Air Conditioning, Refrigerating, Air Handling and Ventilation Systems.

The series is available in the following versions:

- **ALL-in-ONE** (multi-input), with 4 control inputs, 3 inputs for mA-Vdc-NTC sensors and 1 0-10Vdc control signal, for MASTER-SLAVE operating modes.
- **SLAVE-ONE**, with 1 input for 0-10Vdc (Slave-SV) or PWM (Slave-SP) control signals, to be used as single regulation units or as additional modules in order to share out the overall controlled power, only for SLAVE operating mode.

With the **ALL-in-ONE** mode, the selection of input signal and operating mode are performed automatically: the controller operates through the presently active sensor/signal and there is NO need to use any selection or programming hardware device.

The regulator selects the currently ACTIVE control signal, according to the mode preset by the Jumpers.

It is possible to modify the **factory** settings **during the installation procedure of the device**, by moving the following JUMPERS:

- J1**, operating mode: **DIRECT** - the VAC output increases as the control signal value increases
REVERSE - the VAC output decreases as the control signal value increases
- J2**, VAC fans at Set Point: VAC/RMP = 100% with **SP = MAX**, the Set-P corresponds to the fans Max-speed
VAC/RPM = 0% with **SP = MIN**, the Set-P corresponds to the fans Min-speed
- J3**, operation of trimmer P2: **MIN** for the Min. AC voltage limit supplied to the connected motor;
(J1 for SLAVE-SV) **Cut-Off** for the AC voltage limit of the connected motor;
- J4**, output for Slave units control: with control signal for SLAVE-SV units, with **0-10Vdc** input signal
with control signal for SLAVE-SP units, with PWM input signal

While the Proportional Band (Pb) values are already factory preset (see Table: Operating Parameters), the Set Point values are determined through a couple of 13-position rotary switches: **SP** and **SP_{adj.}**, which are intended to be used quickly and easily even by base users. The selection of the Set Point is immediate, and two LEDs (+ & -) will show the relationship between this desired value and the signal value perceived through the presently active sensor; the Set Point will be reached when both LEDs will be off.

In addition, there are LEDs indicating the selection of the First or Second Set Point (only for optional card with double Set Point), and a LED showing the presence of power supply.

With the SLAVE-ONE version, two types of SLAVE units are available: SV (input 0-10Vdc), and SP (input PWM).

All **ESY-1** units are equipped with:

- Complete galvanic separation between AC mains supply and control inputs;
- EMC mains filter with Residential, Commercial & Light Industrial limit (conformity with PDS systems), fit to be used with equipment directly connected to the low voltage mains supply;
- Overvoltage protection on the mains supply;
- Short circuit protection on the connection of the control sensors/signals;
- Protection filters on control inputs

The **ESY-1** series is available in the sizes **8A-12A-16A-20A**, with single phase supply voltage **230V/50Hz**, and it is housed in a **GW-Plast 120°C** case with protection degree **IP55** and high impact resistance, for out of doors installations (**-20T50**).

The controller can be used both in **Condenser** mode (pressure transducer) and in **Dry-Cooler** mode (temperature probe) without the need of any further configuration or programming, with two operating SET-Points (selection of Set-Point 1 & 2), beside the Remote-SLAVE Unit mode, when driven by an external controller generating a 0-10Vdc control signal.

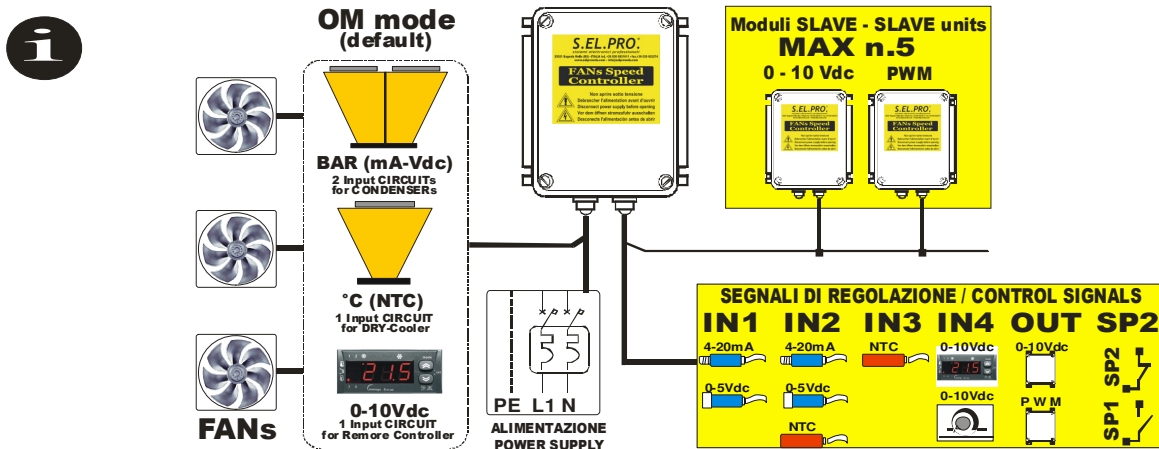

60Hz applications: only with factory calibration

The regulator works correctly also with 60 Hz, but it is necessary to calibrate the output signal to 100% in order to optimize the regulation and avoid pulse and beat frequencies.

4. TECHNICAL CHARACTERISTICS ESY-1

POWER SUPPLY	Voltage		230VAC ± 10 % single phase – (on request 110VAC - 400VAC)				
	Frequency		50Hz standard (60 Hz only factory calibration)				
	Overvoltage Protection		for installation Category II (4 KV)				
OPERATING PRINCIPLE	Electronic analog regulators of single-phase AC voltage, which use the phase-cutting principle (Triac) in order to vary the output active voltage applied to a resistive or inductive load.						
CURRENT	Rated	ESY 08		08 A up to 50°C environment; if over, decrease 0,4 A/°C			
		ESY 12		12 A up to 50°C environment; if over, decrease 0,6 A/°C			
		ESY 16		16 A up to 50°C environment; if over, decrease 0,8 A/°C			
		ESY 20		20 A up to 50°C environment; if over, decrease 1,0 A/°C			
	Starting current (for loads upstream of the regulator)	ESY 08		16A			
		ESY 12		24A			
		ESY 16		32A			
ESY 20		40A					
Overload		200% of the rated current (max. 10" every 3')					
POWER	Control Circuit		3VA				
	Thermally dissipated		1,3 W per supplied Ampere				
OPERATING CHARACTERISTICS	Master (Controller Mode) (inputs IN1,IN2,IN3)		The output voltage varies in order to maintain the value measured by the transducer within the proportional band (Pb = factory calibration)				
	Slave (Power Unit Mode) (Input IN4)		The output voltage varies according to the 0-10 Vdc control signal applied to the input IN4, according to the current configuration.				
CONTROL SIGNALS AND CONTACTS	ALL-in-ONE	standard	Config. 0M	Master (Controller)	IN 1	4-20 mA for 100 ohm (R)	
					IN 2	4-20 mA for 100 ohm (R)	
					IN 3	NTC 10kohm @ 25°C	
				Slave (Power Unit)	IN 4	0-10Vdc for 10 kohm	
			On request	Config. 0X	Master (Controller)	IN 1	4-20 mA for 100 ohm (R) ,
						IN 2	NTC 10 kohm @ 25°C
					IN 3	NTC 10 kohm @ 25°C	
		Config. 0V	Master (Controller)	IN 1	0-5 Vdc		
				IN 2	0-5 Vdc		
				IN 3	NTC 10 kohm @ 25°C		
		Config. 0B	Master (Controller)	IN 1	4-20 mA for 100 ohm (R)		
				IN 2	0-5 Vdc		
	IN 3		NTC 10 kohm @ 25°C				
	Slave (Power Unit)	IN 4	0-10Vdc for 10 kohm				
Contact for Set-Point switching			SP2: selection of Set Point 1 or Set Point 2 (option Double Set-Point)				
SLAVE ONE	Standard	Config. SV	Slave (Power Unit)	IN 1	0-10Vdc for 10 kohm		
		Config. SP	Slave (Power Unit)	IN 1	PWM (PPM-Triac) control voltage 5V÷30V		
OPERATING PARAMETERS	Set-Point Regulation		Easy adjustment with couple of 13-position rotary switches				
	Input type		4-20 mA	0 - 5 Vdc	NTC 10K @ 25°C		
	Main Set Point (SP)		8÷18 mA	0,5 - 4,5 Vdc	10÷60 °C		
	Step Set Point adjustment (SPadj)		0,1 mA	0,04 Vdc	0,5 °C		
	Proportional Band (default)		2,5 mA	0,65 Vdc	7°C		
	Minimum/Cut-Off limit		Adjustable from 0% to 70% of the output voltage				
	Maximum limit		Adjustable from 100% to 0% of the output voltage				
	Acceleration time (default)		5"				
	Operating mode		DIRECT (DIR) VAC output increases as the input value increases) REVERSE (REV) VAC output decreases as the input value increases)				
	AC voltage at Set Point		Selection of MAX Vac value – maximum fan speed Selection of MIN Vac value – minimum fan speed				
	Lower VAC limit		Selection of Cut-Off limit (C-Off) o Selection of MAX Vac Limit (MIN)				
	Slave Units AUX. control		Selection for Analog 0-10Vdc signal (three / single phase supply) Selection for logic PWM signal (same as the remote unit supply)				
LED SIGNALS	DL1		Power Supply O.K.				
	-		Signal value is lower than Set-Point value		± 30% of the Proportional Band (Pb)		
	+		Signal value is higher than Set-Point value				
	1		Set-Point 1 selection		Available optional card with Double Set-Point function		
	2		Set-Point 2 selection				

OUTPUT SIGNALS	Config. 0M	V1	Transducer voltage supply	22V (+10/-20%) max. 25mA
		V2	Transducer voltage supply	22V (+10/-20%) max. 25mA
		+ 10V	Transducer voltage supply	10,0V (±1%)
		OUT	Output signal for slave unit: 0-10Vdc or PWM (MAX 5 modules)	
	Config. 0X	V1	Transducer voltage supply	22V (+10/-20%) max. 25mA
		V2	Transducer voltage supply	22V (+10/-20%) max. 25mA
		+ 10V	Transducer voltage supply	10,0V (±1%)
		OUT	Output signal for slave unit: 0-10Vdc or PWM (MAX 5 modules)	
	Config. 0V	V1	Transducer voltage supply	5,0V (±1%)
		V2	Transducer voltage supply	5,0V (±1%)
		+ 10V	Transducer voltage supply	10,0V (±1%)
		OUT	Output signal for slave unit: 0-10Vdc or PWM (MAX 5 modules)	
	Config. 0B	V1	Transducer voltage supply	22V (+10/-20%) max. 25mA
		V2	Transducer voltage supply	5,0V (±1%)
		+ 10V	Transducer voltage supply	10,0V (±1%)
		OUT	Output signal for slave unit: 0-10Vdc or PWM (MAX 5 modules)	
Config. SV	+ 10V	Transducer voltage supply		
	OUT	Output signal for slave unit: PWM (MAX 5 modules)		
PROTECTIONS	EMC mains filter Compliance 89/336		Conformity for devices that are directly connected to the low voltage mains	
	Overvoltage Protection		Complying with EN 61000-4-5 : overvoltage category II (4 KV)	
	Control Input Protection		Protection from electrical disturbances of the connection	
	Transducer Supply Protection		Protection from short circuit of the transducer output supply	
CASE	Materials		GW-Plast 120°C (max. temperature 120°C) aluminium, fiberglass	
	Protection degree		IP 55 (standard) IP 00 (on request)	
	MAX Heatsink Temperature		60°C	
	Environmental Pollution		Low Pollution	
	Fire Resistance		D Category	
INSULATION	Endurance of the insulation materials against electrical stress		Long	
	Control Circuits	Class I (use of protective earthing conductor)		
		2000 Vac between grounding and voltage supplied components of the device		
2500Vac between control input and voltage supplied components of the device 4000 Vac between control input and mains supplied components				
WORK ENVIRONMENT	Working Temperature		-20 T 50 (from -20°C to + 50°C)	
	Storage Temperature		-30 T 85 (from -30°C to + 85°C)	
	Vibrations		Lower than 1G (9.8 m/s ²)	
	Ageing Characteristics		60.000 hours	
INSTALLATION	Wall mounting ONLY in vertical position, with N° 4 holes Ø 5 mm, providing at least 10 mm insulation around the device			

The device is suitable for the installation in class I, II, III equipments .

5. ELECTRICAL CONNECTIONS

Connect the controller as shown in the figure below, paying attention to the following points.

5.1. Power Supply Connection (Terminal Block M1)

- Before supplying power to the unit, check carefully the power connection and the efficiency of **EARTH** connection.
 - Ensure that power conductors and **EARTH CABLES** have a cross section **suitable to the connected load**.
 - Place a couple of fuses with suitable amperage upstream of the disconnecter.**
 - Do **NOT** install the device in environments where ambient temperature may exceed the maximum values allowed ($T_{amb} \leq 50^{\circ}C$).
 - Mount the equipment vertically, in order to encourage heat dissipation and to ensure sufficient air circulation in a free space measuring at least 150 mm above and below the regulator.
 - If the mains supply is "disturbed", which may be due to other electrical power components causing irregularities in the supply, it is recommended to install supplementary SINGLE phase 'SURGE ARRESTER' filters directly on the regulator supply.
 - Do **NOT** alter or damage the identification stickers on the equipment.
 - NEVER** force the rotary switches beyond their mechanical end stops.
- The power cables (power supply and load), must be installed separately from the control cables, keeping the maximum possible distance between the power and signal conductors.
- Do not mix power cables and signal cables in the same raceway. Where cables must cross one another, ensure they are at an angle as near to 90° as possible to minimize interference.**

WARNING : Use heat resistant cables, able to withstand a temperature rated at 90° or above.

SURGE ARRESTER : electric protection placed between the regulator supply and the earth, meant to protect the device from transient overvoltage.
WARNING: Do NOT use differential switches with values lower than 100mA

-It is advisable to provide a by-pass switch in order to run the load even in case of disconnecter failure (emergency by-pass). When connecting the by-pass, it is necessary to keep the phase correspondence unaltered.

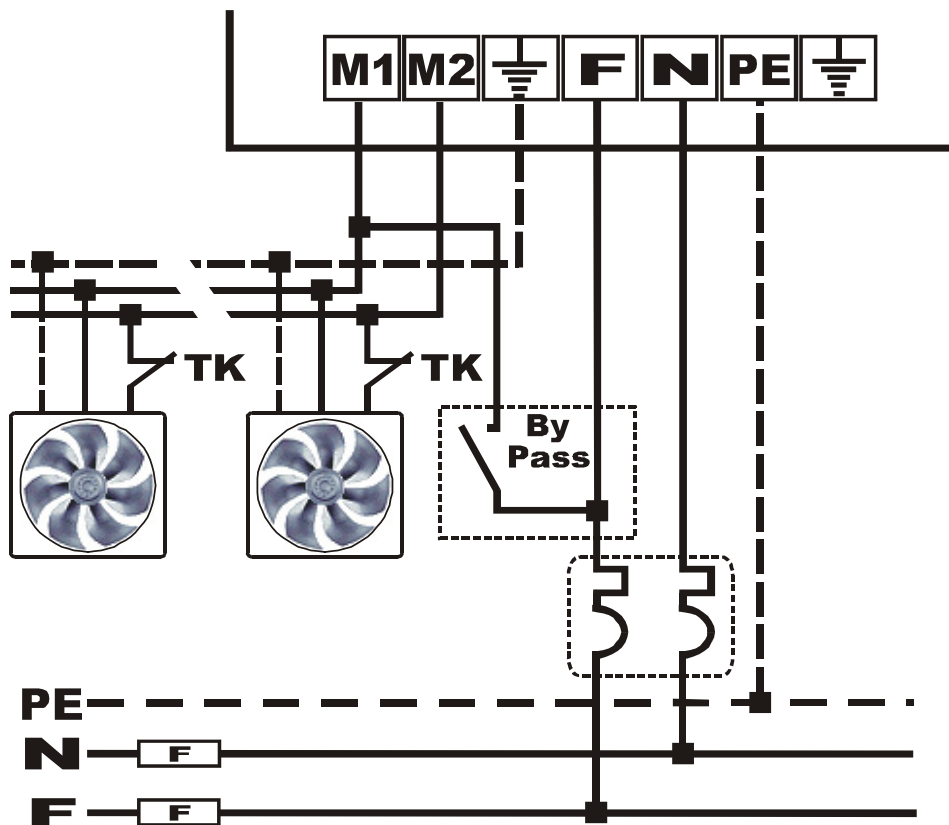

6. SIGNAL CONNECTIONS for the 4 CONFIGURATIONS (ALL-in-ONE)

After checking carefully all power supply connections, connect the input signal/s and supply the card.
The output voltage varies from zero Vac to 230 Vac, according to the variation of the control signal.

⚠ For the connection of the control signal, use an ordinary twisted-pair cable in disturbance-free environments, while in presence of environmental electromagnetic disturbances use a shielded twisted cable with the screen connected to earth, keeping it as far away as possible from other power cables.

⚠ The function modes, both always available in the present series, can be:

- **MASTER** with Set-Point, using the inputs **In1–In2–In3** (for 4-20mA, 0-5Vdc or NTC probe)
- **SLAVE**, using the input **In4** (for 0-10V control signal)

The controllers of the ESY-1/ALL-in-ONE series can be set in the following four (4) configurations, described below.

The OM configuration is standard SELPRO

6.1. OM CONFIGURATION (STANDARD SELPRO)

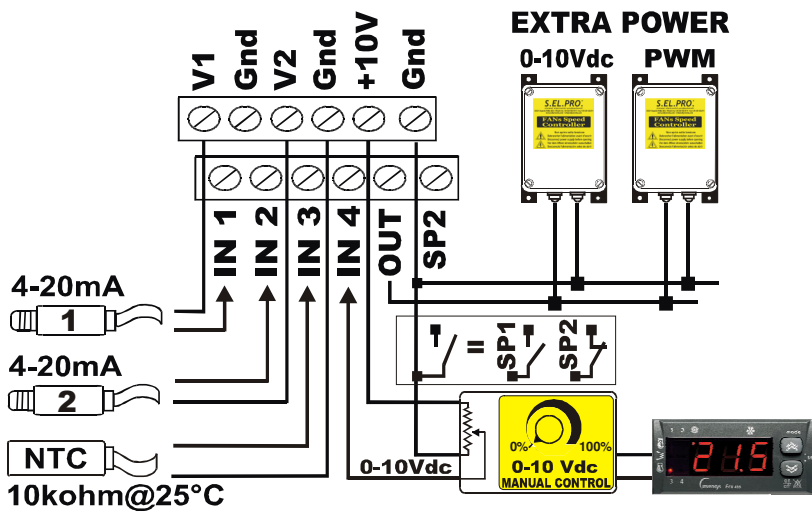

N°	Name	Function	OM CONF.
1	V1	Output voltage supply	22V (+10/-20%) max. 25 mA
2	IN1	Transducer Input N° 1	4-20 mA
3	GND	Ground	GND
4	IN2	Transducer Input N° 2	4-20 mA
5	V2	Output voltage supply	22V (+10/-20%) max. 25 mA
6	IN3	Transducer Input N° 3	NTC 10kohm @ 25°C
7	GND	Ground	GND
8	IN4	Input N° 4 (only SLAVE control)	0-10Vdc
9	+10V	Output voltage supply	10,0V ±1%
10	OUT	“Slave” modules control Output	0-10Vdc / PWM
11	GND	Ground	GND
12	SP2	Set-Point 1& 2 selection Contact	Open = SP1 Closed = SP2

6.2. OX Configuration (on request)

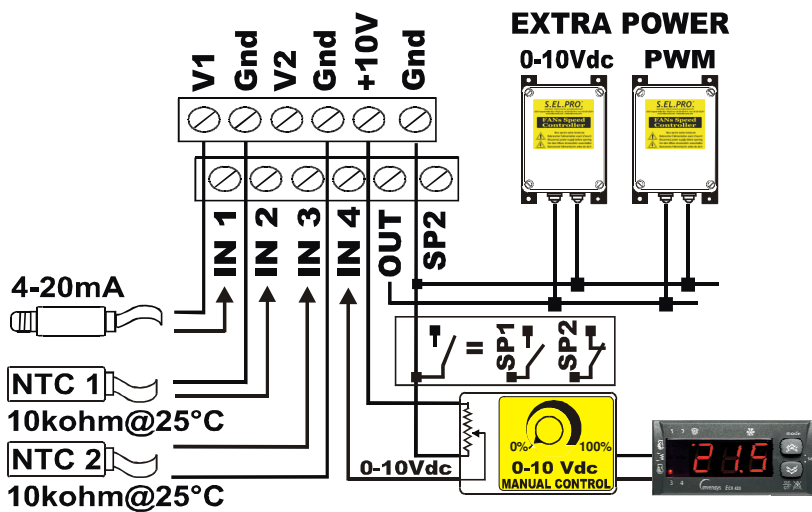

N°	Name	Function	OX CONF.
1	V1	Output voltage supply	22V (+10/-20%) max. 25 mA
2	IN1	Transducer Input N° 1	4-20 mA
3	GND	Ground	GND
4	IN2	Transducer Input N° 2	NTC 10kohm @ 25°C
5	V2	Output voltage supply	22V (+10/-20%) max. 25 mA
6	IN3	Transducer Input N° 3	NTC 10kohm @ 25°C
7	GND	Ground	GND
8	IN4	Input N° 4 (only SLAVE control)	0-10Vdc
9	+10V	Output voltage supply	+10,0V ±1%
10	OUT	“Slave” modules control Output	0-10Vdc / PWM
11	GND	Ground	GND
12	SP2	Set-Point 1& 2 selection Contact	Open = SP1 Closed = SP2

6.3. OV Configuration (on request)

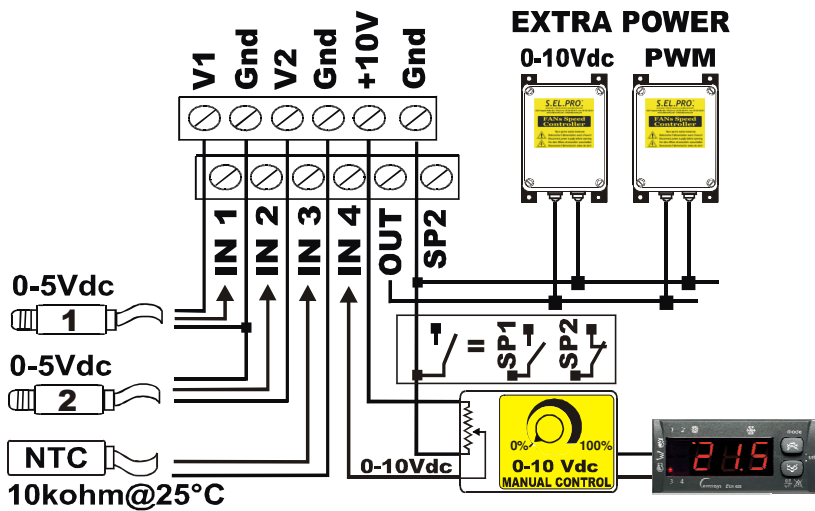

N°	Name	Function	OV CONF.
1	V1	Output voltage supply	+ 5,0V ±1%
2	IN1	Transducer Input N° 1	0-5 Vdc
3	GND	Ground	GND
4	IN2	Transducer Input N° 2	0-5 Vdc
5	V2	Output voltage supply	+ 5,0V ±1%
6	IN3	Transducer Input N° 3	NTC 10kohm @ 25°C
7	GND	Ground	GND
8	IN4	Input N° 4 (only SLAVE control)	0-10Vdc
9	+10V	Output voltage supply	+10,0V ±1%
10	OUT	“Slave” modules control Output	0-10Vdc / PWM
11	GND	Ground	GND
12	SP2	Set-Point 1& 2 selection Contact	Open = SP1 Closed = SP2

6.4. OB Configuration (on request)

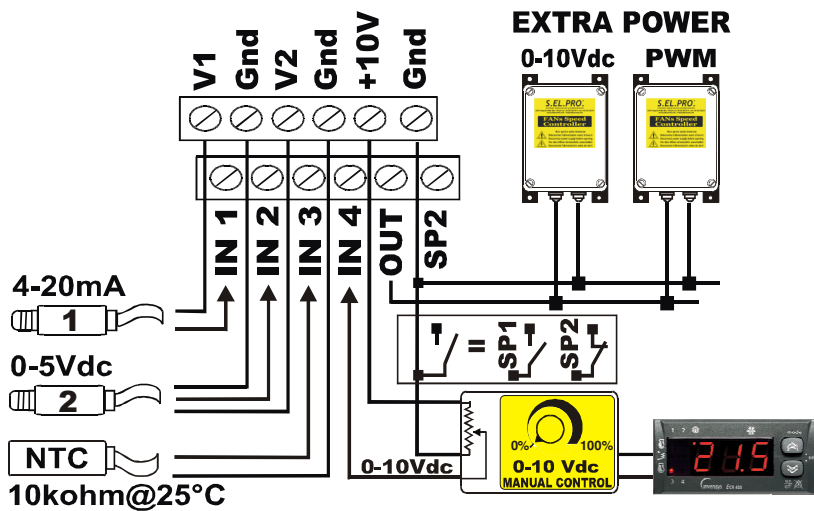

N°	Name	Function	OB CONF.
1	V1	Output voltage supply	22V (+10/-20%) max. 25 mA
2	IN1	Transducer Input N° 1	4-20 mA
3	GND	Ground	GND
4	IN2	Transducer Input N° 2	0-5 Vdc
5	V2	Uscita tensione alimentazione	+ 5,0V ±1%
6	IN3	Transducer Input N° 3	NTC 10kohm @ 25°C
7	GND	Ground	GND
8	IN4	Input N° 4 (only SLAVE control)	0-10Vdc
9	+10V	Output voltage supply	+10,0V ±1%
10	OUT	“Slave” modules control Output	0-10Vdc / PWM
11	GND	Ground	GND
12	SP2	Set-Point 1& 2 selection Contact	Open = SP1 Closed = SP2

7. Electrical connection for Slave Module/s

The controllers of the **ESY-1 / ALL-in-ONE** series include moreover the **SLAVE-ONE** power units, in the two following versions:

- **SLAVE-SV** with input for **0-10Vdc** control signal
- **SLAVE-SP** with input for **PWM** control signal

All the models of the series share the same technical characteristics and are available in different sizes:

8 A – 12 A – 16 A – 20 A, 230Vac/50Hz, all suitable for outdoor applications, in plastic case **120°C** and protection degree **IP55**.

Moreover, the **SLAVE-SV** control unit, with control input 0-10Vdc has an auxiliary output that allows to control further **SLAVE-SP** units.

By using exclusively **SLAVE-SV** units, it is possible to share equally the total load on the three-phases (**R-S-T**), so as to prevent the risk of overloading the electric line on just one phase (regulation performed by two or more controllers, which have the **0-10Vdc** control signal in common).

The **SLAVE-SV** modules do **not** require the same supply phase for every module connected to the **0-10Vdc** control signal (network synchronization), which is instead needed when connecting **SLAVE-SP** units (PWM input).

7.1. Connection of SLAVE modules, SV series (0-10Vdc power units)

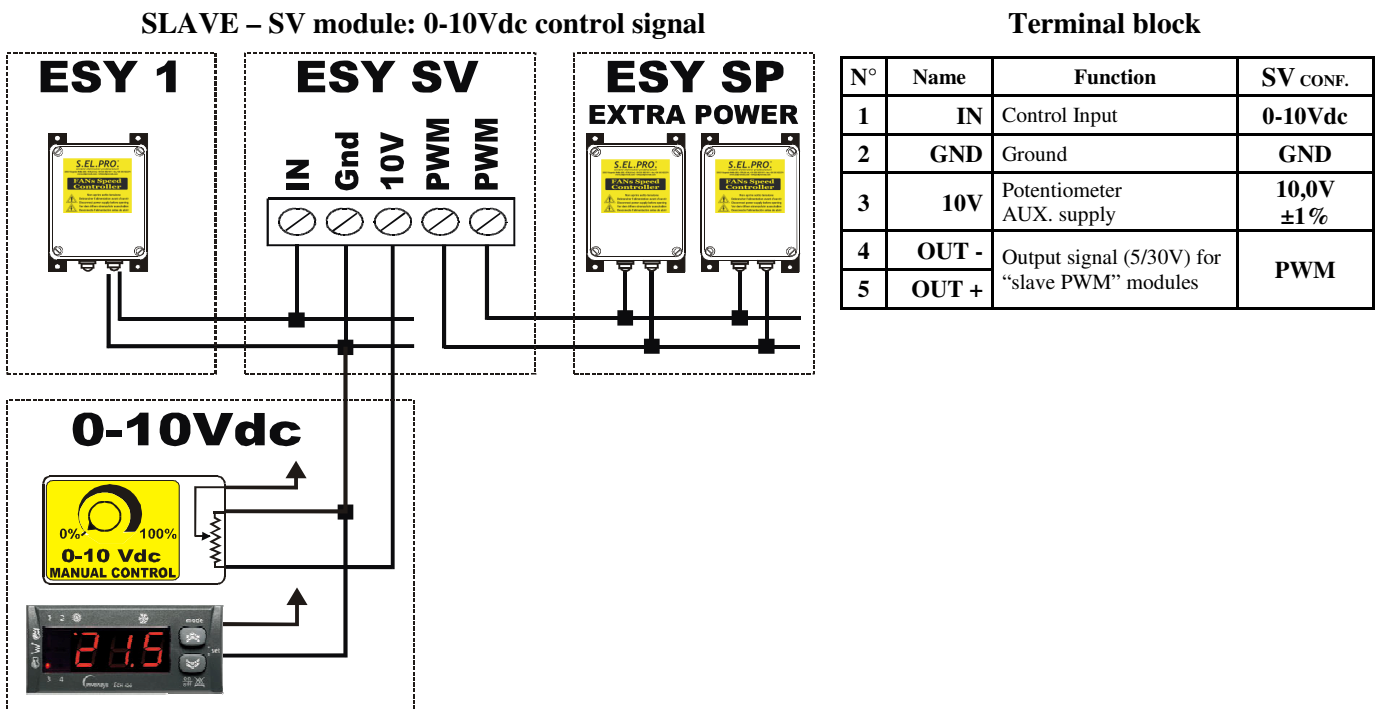

7.2. Connecting ESY-1 to SLAVE-SV / 0-10 Vdc modules (Three-/Single-phase connection)

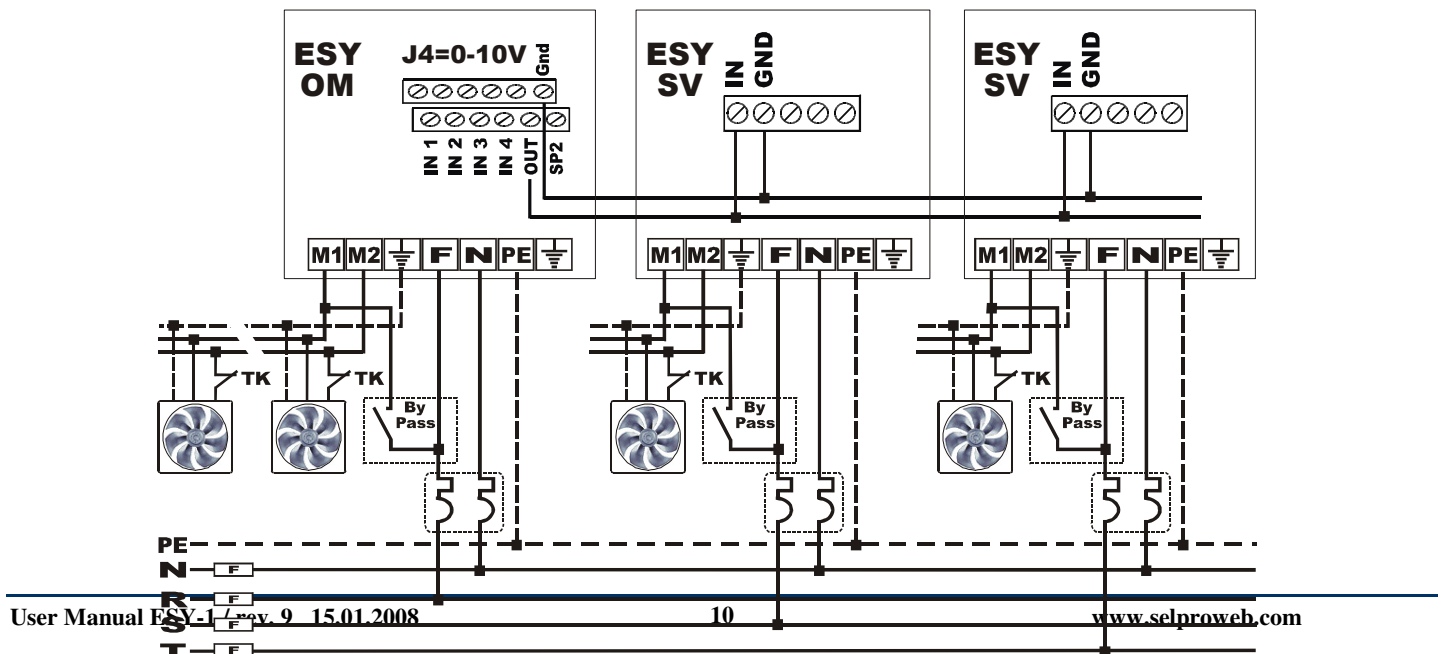

7.3. Connection of SLAVE modules, SP series (PWM power units)

The SLAVE-SP unit allows the connection of the only PWM (PPM-Triac) control signal.

The input is optimized in order to be compatible with every device having a PWM control signal, from 5V to 30V.

All connected SLAVE-SP units require the same supply phase as the remote controller, which generates the PWM control signal (network synchronization)

SLAVE – SP module: PWM control signal

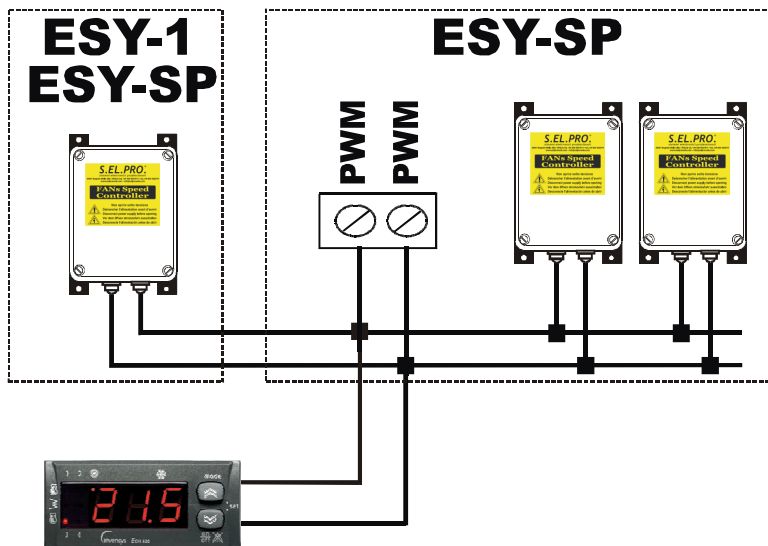

Terminal block		
1	PWM	NON polarized input for PWM control signal (from 5V to 30V)
2	PWM	

7.4. Connecting SLAVE-SP modules – Power supply in phase with the Master unit (network synchronization)

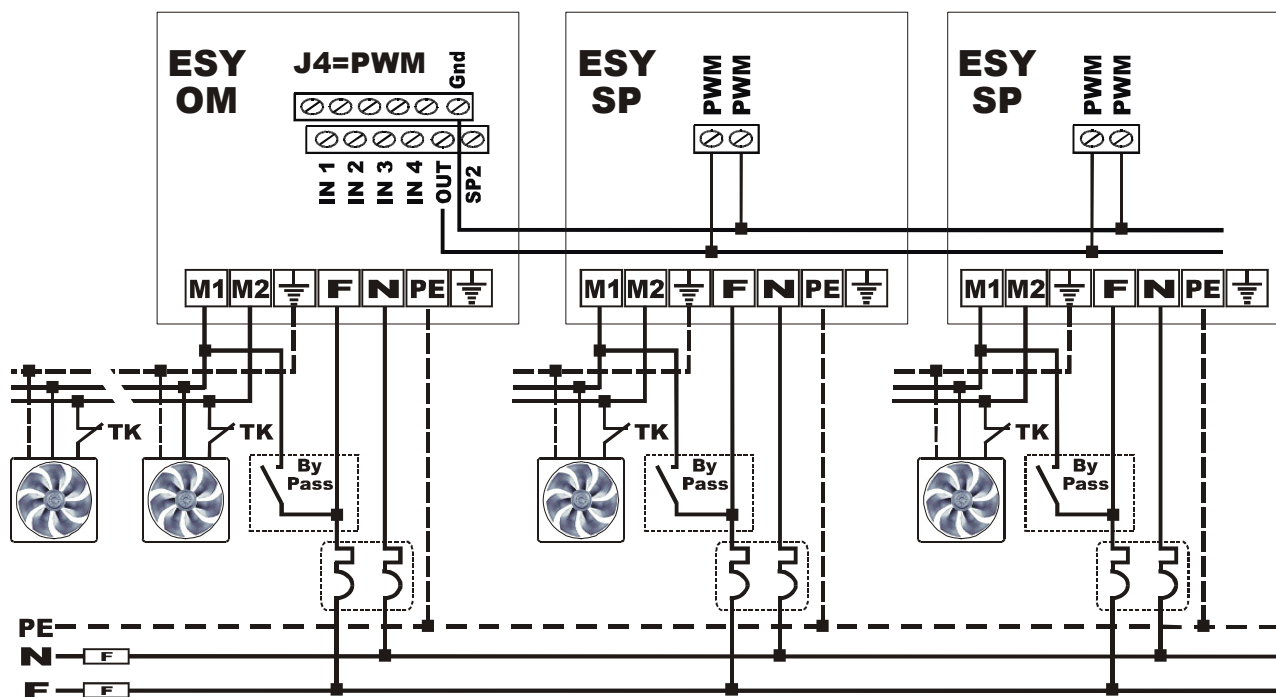

8. ESY-1: CONTROL & POWER CARD IN DETAIL, ALL-in-ONE version

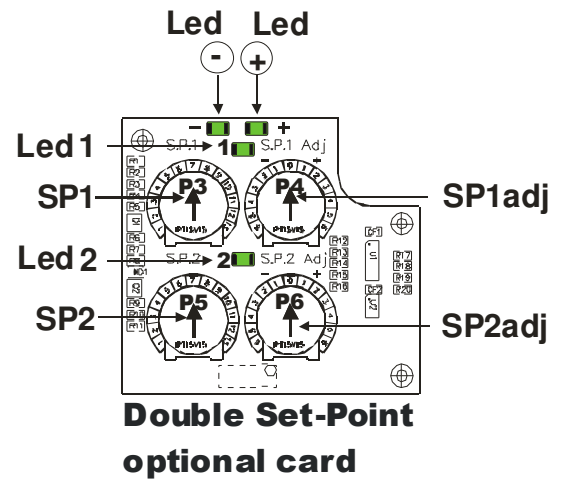
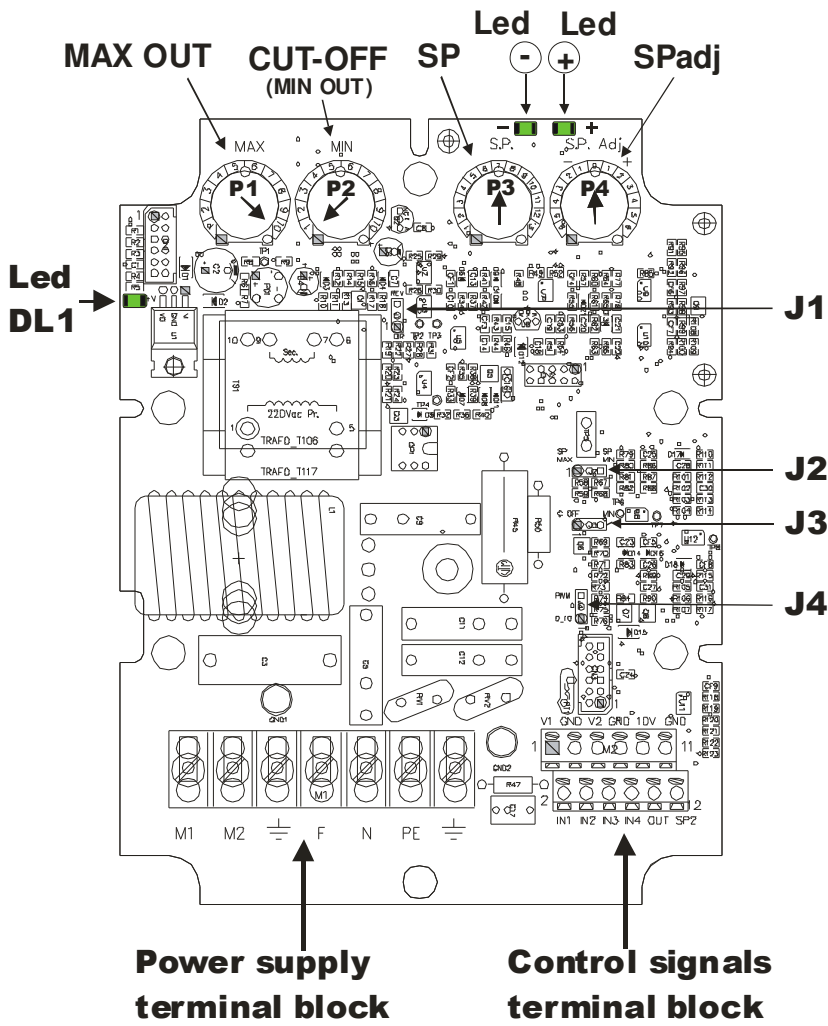

Jumper & LED	Description ESY-1 / ALL-in-ONE
J1	DIRECT-REVERSE mode selection
J2	VAC Output at SET-POINT
J3	CUT-OFF / MIN OUT selection
J4	EXTRA-power control Output
DL	Power supply O.K.
DL -	Set-Point higher than sensor signal
DL +	Set-Point lower than sensor signal
1	Set-Point 1 ON
2	Set-Point 2 ON

8.1. ESY-1: CONTROL & POWER CARD IN DETAIL, SLAVE-ONE versions

SLAVE-SV (0-10V)

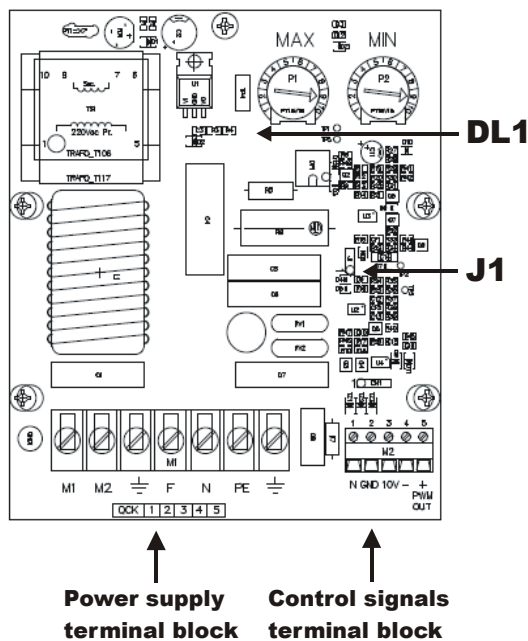

Jumper	Description ESY-1 / SLAVE-SV
J1	CUT-OFF / MIN OUT selection
DL1	Power supply O.K.

SLAVE-SP (PWM)

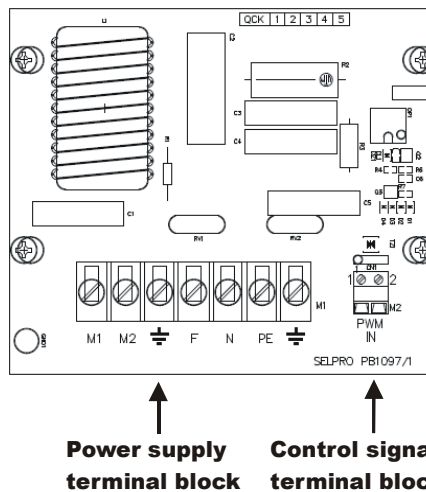

8.2. LED signals

The cards present LED signals, which point out the state and the operation of the controller. The LED signals of the complete version ESY-1 / ALL-in-ONE are shown in the table below:

DL1		Green LED	Power supply O.K.
		Green LED	SP higher than the signal value *
		Green LED	SP lower than the signal value *
1		Green LED	Set-point 1 selection active
2		Green LED	Set-point 2 selection active

* $\pm 30\%$ of the Proportional Band (Pb)

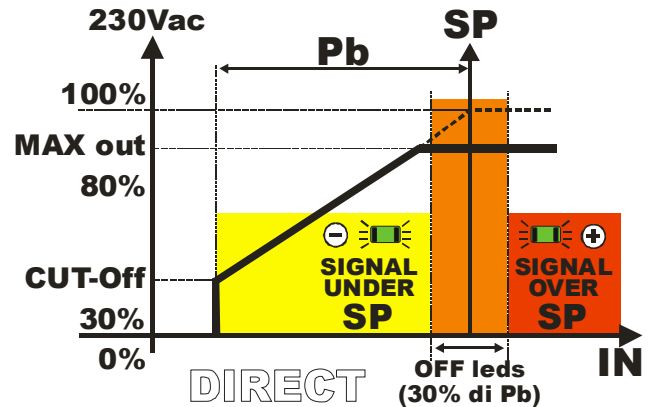

8.3. Configuration and selection JUMPERS

Before starting the set-up procedure for operating parameters and limits, it is necessary to determine the controller's operating modes by moving the configuration jumpers and modifying, when needed, the factory default settings.

Position		Default	Function	Mode	
J1	REV	DIR	Regulation characteristics	Reverse (REV)	
	DIR			Direct (DIR)	
J2	MAX	SP MAX	AC output voltage at Set-Point	MAX AC voltage to fans	
	MIN			MIN AC voltage to fans	
J3 (*J1)	CUT-OFF	CUT-OFF	Type of regulation start	Start / Stop AC voltage	
	MIN			MINIMUM rpm VAC limit	
J4	PWM	0-10Vdc	Control for Extra-power SLAVE SV or SP units	PWM signal – SP unit	
	0-10 Vdc			0-10V signal – SV unit	

(*J1 : symbol for configuration jumper in SLAVE-ONE version)

ATTENTION: With J2 in MAX position (Sp at MAX), the AC output voltage at Set Point is equal to the preset MAX Vac limit value.

9. Set-up of operating LIMITS and PARAMETERS

9.1. Available regulations in the standard ESY-1 version (ALL-in-ONE)

The ESY-1 controllers present two regulation Trimmers for setting up the operating limits (MIN out / Cut-Off and MAX out), the automatic regulation performs the variations of fans speed, and a couple of 13-positions rotary switches for setting up the SET-Point of reference with ease.

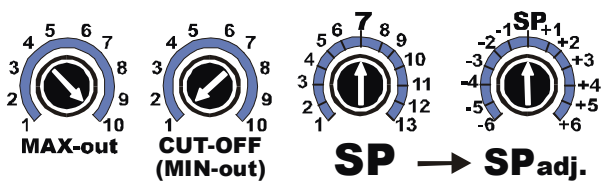

MAX-out	AC voltage limit for MAX-RPM% threshold
CUT-OFF (MIN-out)	AC voltage limit for Cut/Off or MIN-RPM% threshold
SP	Main Set-Point 1 (see following tables for position / value correspondence)
SP adj.	Set-Point 1 for an accurate adjustment of SP (see following tables for position / value correspondence)

9.2. How to set up the operating limits for the ALL-in-ONE version

Before starting the set-up procedure for operating parameters, it is necessary to determine the AC voltage operating limits, within which the automatic variation of speed takes place. The limits must be set up according to the procedures described as follows:

MAX Vac limit	It determines the value of maximum AC voltage to be supplied to the fan in automatic operation (from 100% to 0%), in order to limit the maximum airflow rate or the fan noise at MAX rpm. It is factory preset at the maximum value of '10', corresponding to the 100% of the control value.
Set up of 'MAX out' voltage value: 1) move the Jumper J1 to ON 1(REV) position; 2) turn the trimmer MAX out from position '10' up to the desired value of MAX AC voltage limit; 3) turn the Jumper J1 back to the ON 2 position - in automatic operation, the MAX- RPM% limit of output voltage supplied to the load corresponds to the determined AC voltage limit.	

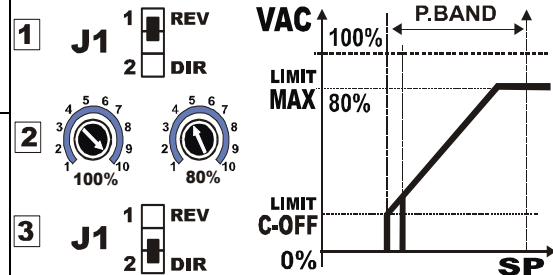

Cut-Off limit	It determines the value of minimum AC voltage to be supplied to the fan in automatic operation (from 25% to 80%): the starting voltage supplied to the fan is enough to give an adequate torque to start the fan rotation.
Set up of 'CUT-OFF' voltage value: 1) move the Jumper J3 to ON 2 position; 2) turn the trimmer from '1' position up to the desired AC voltage value of MIN rpm ; 3) turn the Jumper J3 back to the ON 1 position - the regulation of the fan starts from the determined CUT-Off VAC value	

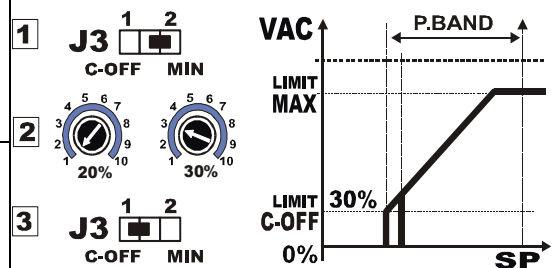

MIN Vac limit	It allows to set up manually the minimum AC output voltage supplied to the fan, from 20% to 80%, and permits to check: - the correct phase-cutting of the controller - the Cut-OFF set up
Set up of 'MIN out' voltage value: 1) move the Jumper J3 to ON 2 position; 2) turn the trimmer from '1' position, until reaching the desired MIN rpm voltage value - At start up the fan operates at the determined minimum Ac voltage limit	

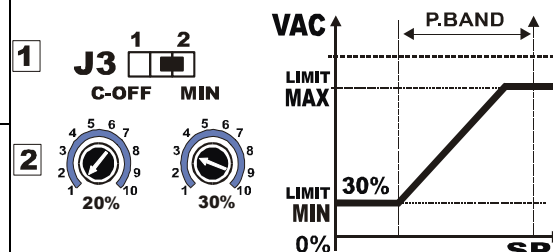

9.3. How to set up the operating limits for SLAVE-ONE modules (only SLAVE-SV version)

The following procedures allow to set up the AC voltage limits, within which the 0-10 Vdc control signal is automatically controlled.

MIN Vac limit	It allows to set up manually the minimum AC output voltage supplied to the fan, from 20% to 90%, and permits to check: - the correct phase-cutting of the controller - the Cut-OFF set up
Set up of 'MIN VAC out' voltage value: 1) move the Jumper J3 in ON 1 position; 2) turn the trimmer from '1' position, until reaching the desired MIN rpm voltage value; now the load is always supplied starting from the determined MAX AC voltage limit	

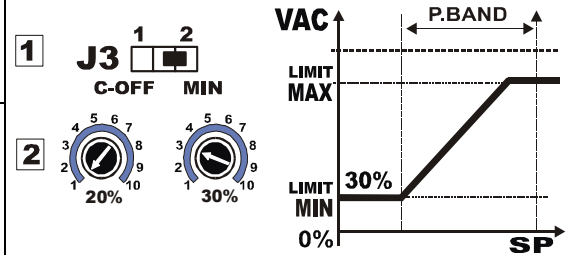

Cut-OFF limit	It determines the value of minimum AC voltage to be supplied to the fan in automatic operation (from 25% to 80%): this prevent the fan to be supplied with a lower AC voltage, which would be not enough to give an adequate torque for keeping the fan rotating.
Set up of 'CUT-OFF' AC voltage value: 1) move the Jumper J3 to ON 1 position; 2) turn the trimmer from '1' position, until reaching the desired MIN rpm voltage value 3) turn the Jumper J3 back to the ON 2 position now the load is supplied starting from the CUT-Off value	

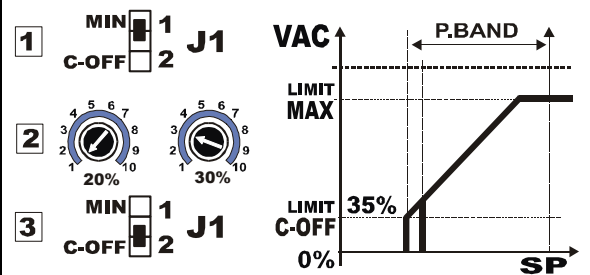

MAX Vac limit	It determines the value of maximum AC voltage to be supplied to the fan in automatic operation (from 100% to 20%), in order to limit the maximum airflow rate or the fan noise at MAX rpm. It is factory preset at the maximum value of '10', corresponding to the 100% of the control value.
Set up of 'MAX out' voltage value: 1) jumper the inputs IN and +10V: the AC voltage output is at 100% 2) turn the trimmer MAX out from position '10' up to the desired value of MAX AC voltage limit (ex.: 80%); 3) remove the jumper between IN and +10V : in automatic operation, the MAX voltage limit supplied to the load corresponds to the determined AC output voltage limit	

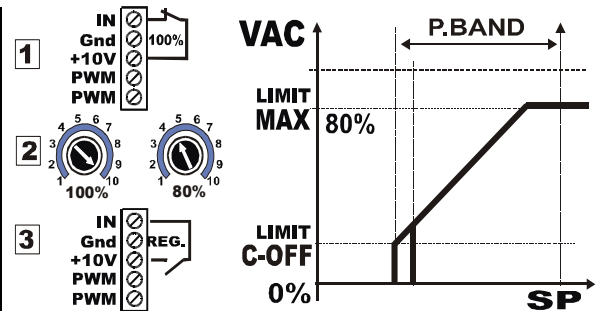

9.4. Table showing the scale of values for setting up the ESY-1 regulation VAC Limits

Scale		(*)	(*)	(*) move the selection jumper in order to pass from the Cut-Off limit to the MIN out limit; always check the difference between VAC values, as shown in the table below
--------------	--	-----	-----	---

Limit	ALL-in-ONE			SLAVE-ONE	
	MAX	C-OFF	MIN	MAX	C-Off (MIN)
1	0	40	60	55	45
2	70	65	85	80	60
3	100	90	110	120	90
4	130	115	135	160	115
5	160	135	150	190	135
6	185	150	160	210	150
7	205	160	170	215	165
8	215	170	180	220	175
9	225	180	190	225	185
10	230	185	190	230	190

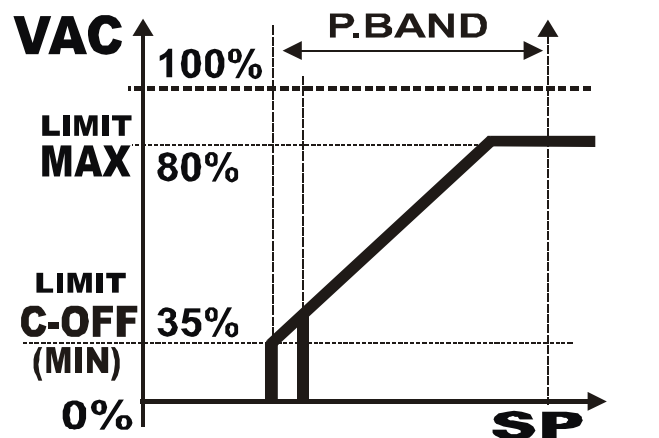

After selecting the operating modes and setting up the operating limits, it is necessary to determine the operating point of the regulation: the **SET-POINT**, on the basis of the scales and ranges referring to the connected sensor (*).

The Set-Point is easily and quickly fixed through the **couple of 13-position rotary switches**, named as follows: **SP** (main reference point for the regulation) and **SPadj.** (accurate adjustment of the operating point fixed with SP).

For the selection of the Set-Point values, refer to the following tables according to the ranges and to the types of sensors in use.

(*) The controller **ESY-1** operates automatically according to the sensor/signal currently connected or in use.

9.5. Tables for the Set-Point selection:

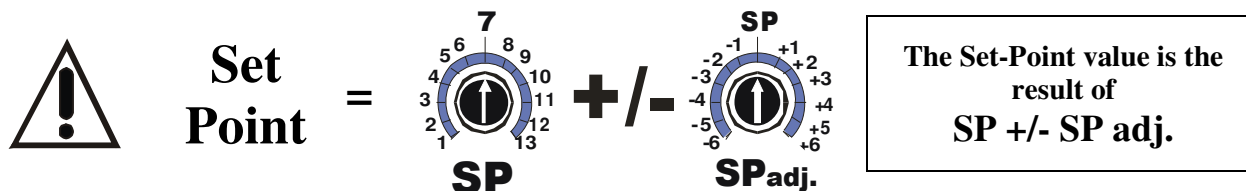

9.5.1. Set-Point values, range 4-20 mA (Transducer 4-20 mA)

						4-20mA							
-6	-5	-4	-3	-2	-1			+1	+2	+3	+4	+5	+6
7,00	7,05	7,15	7,25	7,35	7,45	1	7,56	7,66	7,76	7,86	7,96	8,06	8,11
7,51	7,56	7,66	7,76	7,86	7,96	2	8,06	8,16	8,26	8,36	8,46	8,56	8,61
8,51	8,56	8,66	8,76	8,86	8,96	3	9,06	9,16	9,26	9,36	9,46	9,56	9,61
9,51	9,56	9,66	9,76	9,86	9,96	4	10,06	10,16	10,26	10,36	10,46	10,56	10,61
10,51	10,56	10,67	10,77	10,87	10,97	5	11,07	11,17	11,27	11,37	11,47	11,57	11,62
11,52	11,57	11,67	11,77	11,87	11,97	6	12,07	12,17	12,27	12,37	12,47	12,57	12,62
12,52	12,57	12,67	12,77	12,87	12,97	7	13,07	13,17	13,27	13,37	13,47	13,57	13,62
13,52	13,57	13,67	13,78	13,88	13,98	8	14,08	14,18	14,28	14,38	14,48	14,58	14,63
14,53	14,58	14,68	14,78	14,88	14,98	9	15,08	15,18	15,28	15,38	15,48	15,58	15,63
15,53	15,58	15,68	15,78	15,88	15,98	10	16,08	16,18	16,28	16,38	16,48	16,58	16,63
16,53	16,58	16,68	16,78	16,88	16,99	11	17,09	17,19	17,29	17,39	17,49	17,59	17,64
17,54	17,59	17,69	17,79	17,89	17,99	12	18,09	18,19	18,29	18,39	18,49	18,59	18,64
18,04	18,09	18,19	18,29	18,39	18,49	13	18,59	18,69	18,79	18,89	18,99	19,09	19,14

9.5.2. Set-Point values, range 0-15 bar (Transducer 4-20 mA)

						0-15 bar							
-6	-5	-4	-3	-2	-1			+1	+2	+3	+4	+5	+6
2,82	2,86	2,96	3,05	3,14	3,24	1	3,33	3,43	3,52	3,62	3,71	3,80	3,85
3,29	3,33	3,43	3,52	3,62	3,71	2	3,80	3,90	3,99	4,09	4,18	4,27	4,32
4,23	4,27	4,37	4,46	4,56	4,65	3	4,74	4,84	4,93	5,03	5,12	5,21	5,26
5,17	5,21	5,31	5,40	5,50	5,59	4	5,68	5,78	5,87	5,97	6,06	6,15	6,20
6,11	6,15	6,25	6,34	6,44	6,53	5	6,62	6,72	6,81	6,91	7,00	7,09	7,14
7,05	7,09	7,19	7,28	7,38	7,47	6	7,57	7,66	7,75	7,85	7,94	8,04	8,08
7,99	8,04	8,13	8,22	8,32	8,41	7	8,51	8,60	8,69	8,79	8,88	8,98	9,02
8,93	8,98	9,07	9,16	9,26	9,35	8	9,45	9,54	9,63	9,73	9,82	9,92	9,96
9,87	9,92	10,01	10,10	10,20	10,29	9	10,39	10,48	10,57	10,67	10,76	10,86	10,90
10,81	10,86	10,95	11,05	11,14	11,23	10	11,33	11,42	11,52	11,61	11,70	11,80	11,84
11,75	11,80	11,89	11,99	12,08	12,17	11	12,27	12,36	12,46	12,55	12,64	12,74	12,79

12,74	12,83	12,93	13,02	13,11	12	13,21	13,30	13,40	13,49	13,58	13,68	13,73
13,16	13,21	13,30	13,40	13,49	13,58	13	13,68	13,77	13,87	13,96	14,05	14,20

9.5.3. Set Point values, range 0-25 bar (Transducer 4-20 mA)

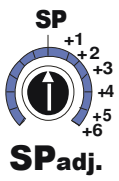
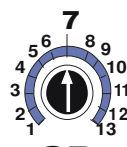
						0-25 bar							
-6	-5	-4	-3	-2	-1			+1	+2	+3	+4	+5	+6
4,69	4,77	4,93	5,08	5,24	5,40	1	5,55	5,71	5,87	6,03	6,18	6,34	6,42
5,48	5,55	5,71	5,87	6,03	6,18	2	6,34	6,50	6,65	6,81	6,97	7,12	7,20
7,04	7,12	7,28	7,44	7,59	7,75	3	7,91	8,06	8,22	8,38	8,53	8,69	8,77
8,61	8,69	8,85	9,00	9,16	9,32	4	9,47	9,63	9,79	9,94	10,10	10,26	10,34
10,18	10,26	10,41	10,57	10,73	10,88	5	11,04	11,20	11,35	11,51	11,67	11,82	11,90
11,75	11,82	11,98	12,14	12,30	12,45	6	12,61	12,77	12,92	13,08	13,24	13,39	13,47
13,31	13,39	13,55	13,71	13,86	14,02	7	14,18	14,33	14,49	14,65	14,80	14,96	15,04
14,88	14,96	15,12	15,27	15,43	15,59	8	15,74	15,90	16,06	16,21	16,37	16,53	16,61
16,45	16,53	16,68	16,84	17,00	17,15	9	17,31	17,47	17,62	17,78	17,94	18,09	18,17
18,02	18,09	18,25	18,41	18,57	18,72	10	18,88	19,04	19,19	19,35	19,51	19,66	19,74
19,58	19,66	19,82	19,98	20,13	20,29	11	20,45	20,60	20,76	20,92	21,07	21,23	21,31
21,15	21,23	21,39	21,54	21,70	21,86	12	22,01	22,17	22,33	22,48	22,64	22,80	22,88
21,94	22,01	22,17	22,33	22,48	22,64	13	22,80	22,95	23,11	23,27	23,42	23,58	23,66

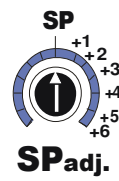
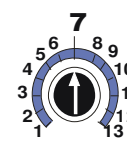

9.5.4. Set Point values, range 0-30 bar (Transducer 4-20 mA)

						0-30 bar							
-6	-5	-4	-3	-2	-1			+1	+2	+3	+4	+5	+6
5,63	5,73	5,91	6,10	6,29	6,48	1	6,67	6,85	7,04	7,23	7,42	7,61	7,70
6,57	6,67	6,85	7,04	7,23	7,42	2	7,61	7,79	7,98	8,17	8,36	8,55	8,64
8,45	8,55	8,74	8,92	9,11	9,30	3	9,49	9,68	9,86	10,05	10,24	10,43	10,52
10,33	10,43	10,62	10,80	10,99	11,18	4	11,37	11,56	11,74	11,93	12,12	12,31	12,40
12,21	12,31	12,50	12,69	12,87	13,06	5	13,25	13,44	13,63	13,81	14,00	14,19	14,28
14,10	14,19	14,38	14,57	14,75	14,94	6	15,13	15,32	15,51	15,69	15,88	16,07	16,17
15,98	16,07	16,26	16,45	16,64	16,82	7	17,01	17,20	17,39	17,58	17,76	17,95	18,05
17,86	17,95	18,14	18,33	18,52	18,70	8	18,89	19,08	19,27	19,46	19,64	19,83	19,93
19,74	19,83	20,02	20,21	20,40	20,59	9	20,77	20,96	21,15	21,34	21,53	21,71	21,81
21,62	21,71	21,90	22,09	22,28	22,47	10	22,65	22,84	23,03	23,22	23,41	23,59	23,69
23,50	23,59	23,78	23,97	24,16	24,35	11	24,54	24,72	24,91	25,10	25,29	25,48	25,57
25,38	25,48	25,66	25,85	26,04	26,23	12	26,42	26,60	26,79	26,98	27,17	27,36	27,45
26,32	26,42	26,60	26,79	26,98	27,17	13	27,36	27,55	27,73	27,92	28,11	28,30	28,39

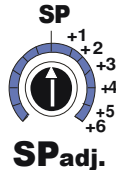
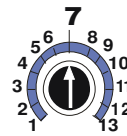
9.5.5. Set-Point values, range 0-45 bar (Transducer 4-20 mA)

						0-45 bar							
-6	-5	-4	-3	-2	-1			+1	+2	+3	+4	+5	+6
8,45	8,59	8,87	9,15	9,43	9,72	1	10,00	10,28	10,56	10,85	11,13	11,41	11,55
9,86	10,00	10,28	10,56	10,85	11,13	2	11,41	11,69	11,97	12,26	12,54	12,82	12,96
12,68	12,82	13,10	13,38	13,67	13,95	3	14,23	14,51	14,80	15,08	15,36	15,64	15,78
15,50	15,64	15,92	16,21	16,49	16,77	4	17,05	17,33	17,62	17,90	18,18	18,46	18,60
18,32	18,46	18,75	19,03	19,31	19,59	5	19,87	20,16	20,44	20,72	21,00	21,28	21,43
21,14	21,28	21,57	21,85	22,13	22,41	6	22,70	22,98	23,26	23,54	23,82	24,11	24,25
23,97	24,11	24,39	24,67	24,95	25,24	7	25,52	25,80	26,08	26,36	26,65	26,93	27,07
26,79	26,93	27,21	27,49	27,77	28,06	8	28,34	28,62	28,90	29,19	29,47	29,75	29,89
29,61	29,75	30,03	30,31	30,60	30,88	9	31,16	31,44	31,72	32,01	32,29	32,57	32,71
32,43	32,57	32,85	33,14	33,42	33,70	10	33,98	34,26	34,55	34,83	35,11	35,39	35,53
35,25	35,39	35,67	35,96	36,24	36,52	11	36,80	37,09	37,37	37,65	37,93	38,21	38,36
38,07	38,21	38,50	38,78	39,06	39,34	12	39,62	39,91	40,19	40,47	40,75	41,04	41,18
39,48	39,62	39,91	40,19	40,47	40,75	13	41,04	41,32	41,60	41,88	42,16	42,45	42,59

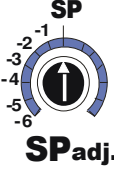
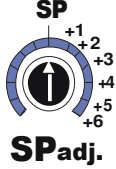
9.5.6. Set Point values, range 0-30 bar (Transducer 0,5-4,5 Vdc)

						0-30 bar							
-6	-5	-4	-3	-2	-1			+1	+2	+3	+4	+5	+6
3,10	3,22	3,47	3,71	3,96	4,20	1	4,45	4,69	4,94	5,18	5,43	5,67	5,79
4,32	4,45	4,69	4,94	5,18	5,43	2	5,67	5,92	6,16	6,41	6,65	6,89	7,02
6,77	6,89	7,14	7,38	7,63	7,87	3	8,12	8,36	8,61	8,85	9,10	9,34	9,47
9,22	9,34	9,59	9,83	10,08	10,32	4	10,57	10,81	11,06	11,30	11,55	11,79	11,91
11,67	11,79	12,04	12,28	12,53	12,77	5	13,02	13,26	13,51	13,75	14,00	14,24	14,36
14,12	14,24	14,49	14,73	14,97	15,22	6	15,46	15,71	15,95	16,20	16,44	16,69	16,81
16,57	16,69	16,93	17,18	17,42	17,67	7	17,91	18,16	18,40	18,65	18,89	19,14	19,26
19,01	19,14	19,38	19,63	19,87	20,12	8	20,36	20,61	20,85	21,10	21,34	21,59	21,71
21,46	21,59	21,83	22,08	22,32	22,56	9	22,81	23,05	23,30	23,54	23,79	24,03	24,16
23,91	24,03	24,28	24,52	24,77	25,01	10	25,26	25,50	25,75	25,99	26,24	26,48	26,60
26,36	26,48	26,73	26,97	27,22	27,46	11	27,71	27,95	28,20	28,44	28,69	28,93	29,05
28,81	28,93	29,18	29,42	29,67	29,91	12	30,15	30,40	30,64	30,89	31,13	31,38	31,50
30,03	30,15	30,40	30,64	30,89	31,13	13	31,38	31,62	31,87	32,11	32,36	32,60	32,73

9.5.7. Set-Point values, range 10°C to 60°C (NTC probe 10kohm@25°C)

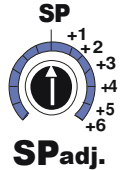
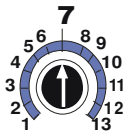
						10-60 °C							
-6	-5	-4	-3	-2	-1			+1	+2	+3	+4	+5	+6
2,00	2,50	3,00	3,50	4,00	4,50	1	5	5,50	6,00	6,50	7,00	7,50	8,00
7,00	7,50	8,00	8,50	9,00	9,50	2	10	10,50	11,00	11,50	12,00	12,50	13,00
12,00	12,50	13,00	13,50	14,00	14,50	3	15	15,50	16,00	16,50	17,00	17,50	18,00
17,00	17,50	18,00	18,50	19,00	19,50	4	20	20,50	21,00	21,50	22,00	22,50	23,00
22,00	22,50	23,00	23,50	24,00	24,50	5	25	25,50	26,00	26,50	27,00	27,50	28,00
27,00	27,50	28,00	28,50	29,00	29,50	6	30	30,50	31,00	31,50	32,00	32,50	33,00
32,00	32,50	33,00	33,50	34,00	34,50	7	35	35,50	36,00	36,50	37,00	37,50	38,00
37,00	37,50	38,00	38,50	39,00	39,50	8	40	40,50	41,00	41,50	42,00	42,50	43,00
42,00	42,50	43,00	43,50	44,00	44,50	9	45	45,50	46,00	46,50	47,00	47,50	48,00
47,00	47,50	48,00	48,50	49,00	49,50	10	50	50,50	51,00	51,50	52,00	52,50	53,00
52,00	52,50	53,00	53,50	54,00	54,50	11	55	55,50	56,00	56,50	57,00	57,50	58,00
57,00	57,50	58,00	58,50	59,00	59,50	12	60	60,50	61,00	61,50	62,00	62,50	63,00
62,00	62,50	63,00	63,50	64,00	64,50	13	65	65,50	66,00	66,50	67,00	67,50	68,00

9.6. Regulation with Double SET-Point (optional)

The controller ESY-1 has been designed to be connected to an optional card with the Double Set-Point function, which allows to determine two operating points: **SP1** & **SP2**. The inclusion of the optional card is factory preset and must be requested when placing the order.

In order to select the CUT-OFF / MIN out and MAX out values, follow the indications given in the table above.

For the selection of **Set-Point 1** & **2** use the input **SP2 + GND** on the terminal block, as indicated below.

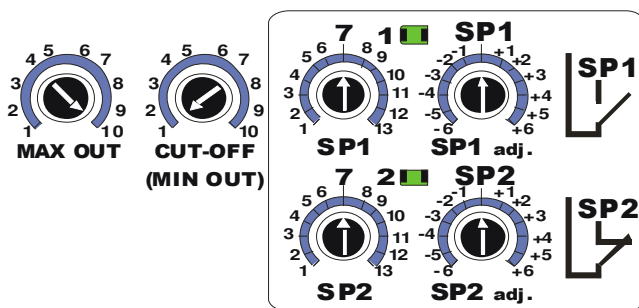

MAX OUT	Maximum RPM/VAC limit
MIN OUT	Minimum RPM/VAC or Cut-Off limit
SP1	Main Set-Point 1 (see following tables for position / value correspondence)
SP1 adj.	Set-Point 1 accurate adjustment (see following tables for position / value correspondence)
SP2	Set-Point 2 (see following tables for position / value correspondence)
SP2 adj.	Set-Point 2 accurate adjustment (see following tables for position / value correspondence)

In order to pass from **Set-Point 1** to **Set-Point 2**, it is necessary to close the preset contact between terminals.

SET-POINT 1 operation

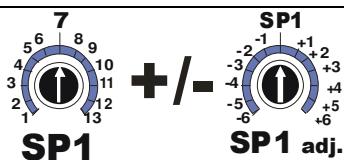

SP1	Set-Point 1
SP1 adj.	Set-Point 1 adjustment
Led 1	Led SP1 = ON
SP2	OPEN

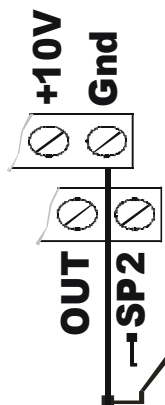

SET-POINT 2 operation

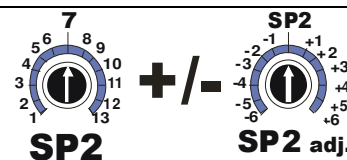

SP2	Set-Point 2
SP2 adj.	Set-Point 2 adjustment
Led 2	Led SP2 = ON
SP2	CLOSED

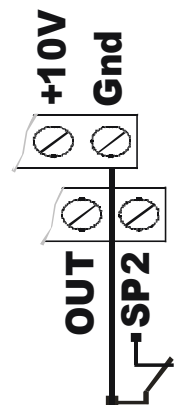

10. Function diagrams & Operating parameters in MASTER & SLAVE modes

Standard values of the proportional band (Pb): transducer 4-20 mA Pb=2.5 mA,
 transducer 0-5 Vdc Pb=0,65 Vdc,
 sensor NTC 10kohm@25°C Pb=7.0°C

MAX=fans maximum rpm - Min= fans minimum rpm - Off= fans off - Vac= voltage supply to the load;

10.1. ESY-1 MASTER mode

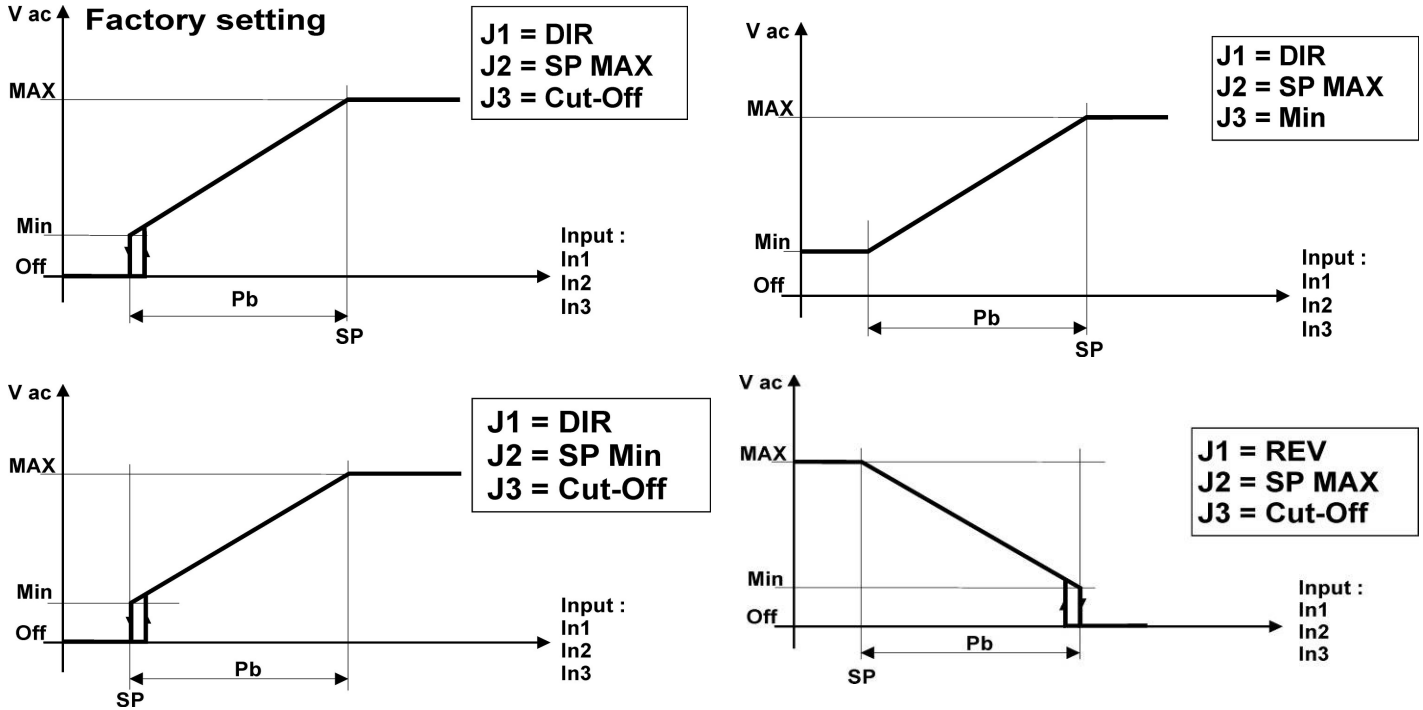

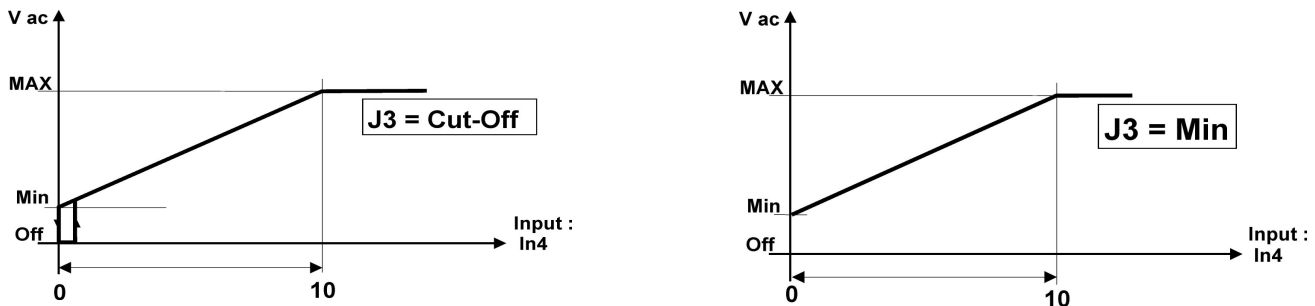

10.2. ESY-1 SLAVE mode

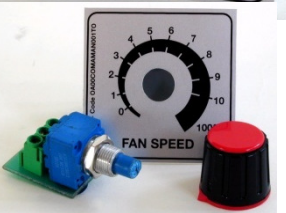

11. ACCESSORIES

11.1. Manual Remote Control Units

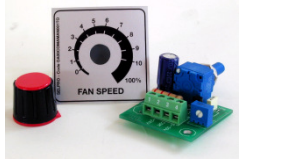
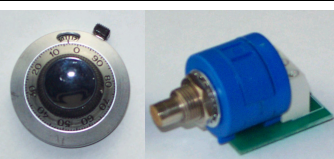
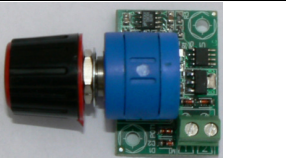
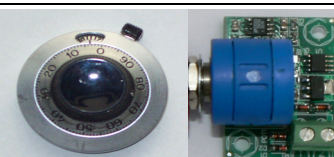
	<p>◆ Series of potentiometers for manual remote control</p> <ul style="list-style-type: none"> - Potentiometer for external remote control - Manual speed setting with 0-10 Vdc - Available 1 & 10 turn versions, with standard knob Ø 22 and silk screen label - Available 10 turn version, with knob Ø 30 with 100 Set-points - Mounting in switch cabinet doors, shaft length 15 mm, Ø 6.3 mm - Complete with front plate 50 x 50 mm 	
	<p>Linear potentiometer for 0-10 Vdc remote manual control</p> <p style="text-align: center;">1 turn – 10kohm – 1 W – in Cermet</p> <p>Front plate with silk screen label 50 x 50 mm and knob diameter Ø 22</p>	
<p>ZC RGF PB1034 00000</p>	<p>Linear potentiometer for 0-10 Vdc remote manual control</p> <p style="text-align: center;">10 turns – 10kohm – 3 W – wire</p> <p>Front plate with silk screen label 50 x 50 mm</p>	 <p>ZC RGF PB1050 20000 with 100-points, Ø 30 knob</p>
	<p>AC voltage converter for manual control:</p> <p style="text-align: center;">Input 24Vdc >>> Output 0-10Vdc</p> <p>with adjustable MAX Vdc-Out LIMIT, for the regulation of:</p> <ul style="list-style-type: none"> - Fan motors - Geared motors for shutters - Geared motors for motorized valves <p>Front plate with silk screen label 50 x 50 mm</p>	 <p>ZC RGF PB1035 20000 with 100-points, Ø 30 knob</p>
	<p>AC voltage converter for manual control:</p> <p style="text-align: center;">Input 24Vdc >>> Output 4-20mA</p> <p>for the regulation of:</p> <ul style="list-style-type: none"> - Fan motors - Geared motors for shutters - Geared motors for motorized valves <p>Front plate with silk screen label 50 x 50 mm</p>	 <p>ZC RGF PB1040 20000 with 100-points, Ø 30 knob</p>

11.2 Pressure Transducer for 4-20 mA & 0-5 V

Description	4-20 mA	0-5 Vdc
Control signal	4 ... 20 mA	0,5 ... 4,5 V
Power supply	8 ... 28 V	5 V +/- 0,25V
Range (bar)	0 ... 15/25/30/45	0 ... 30/45
Linearity	< 0,5 % FS max	
Temperature compensation	0° ... 50°C	
Electrical connection	2 wires	3 wires
Mechanical connection	7/ 16" - 20 UNF	
Protection	IP 65	



11.3 Temperature Probe NTC (10 kohm@25°C)

Sensor NTC probe with resinated terminal
 Connection Silicon (light blue) 3.0 mt cable
 Terminal INOX AISI 304 6 x 40 mm.
 Work range (°C) -50 T 110



11.4 RGF-MEI(4) / UNIVERSAL input Expansion Module

Electronic “All-Round” unit for the connection of 4 additional control and regulation inputs, for all applications with:

Control inputs: 4-20mA, NTC(10k), 0-5Vdc, 0-10Vdc, 0-20mA

Regulation output: 0-10 Vdc / 0-20 mA

Selectable MASTER-SLAVE function for:

- NTC Temperature, Pressure, Remote signals, etc.
- Automatic selection between the MAX/MIN values
- OUTPUT connection to other MEI units (max 3)
- LEDs for the visualization of active inputs
- Power supply protection with fuse
- Power supply “surge” protection
- INPUT total protection against short-circuit
- Protection filters against input signal surge



TECHNICAL ASSISTANCE FORM

- All **ESY-1** equipments are guaranteed for **36** months from the date of testing.
- The guarantee will be rendered invalid under these circumstances:
 - evidence of tampering with the mechanical or electrical parts
 - improper use
 - incorrect installation
 - external electrical causes

Please keep this sheet close to the 'ESY-1' regulator. To improve the assistance service and quick fault diagnosis, please fill this sheet in and send it to the Assistance centre together with the regulator in the event of a breakdown.

Customer:		Regulator model:	
N° di serial no:	Date of installation:	Date of breakdown:	

Description of the anomaly

<input type="checkbox"/> Noisy motor	<input type="checkbox"/> Burnt motor	Burnt power supply fuse		
<input type="checkbox"/> Unbalanced phases	<input type="checkbox"/> Protection interrupt	<input type="checkbox"/> phase R+N	<input type="checkbox"/> phase S+N	<input type="checkbox"/> phase T+N
<input type="checkbox"/> Blocked motor	<input type="checkbox"/> Differential interrupt			

Description:

Control and contacts check card

<input type="checkbox"/> Soft-Start	dE	<input type="checkbox"/> INPUT NTC		<input type="checkbox"/> Contact DIR/REV	S1
<input type="checkbox"/> Prop.Band	Pb	<input type="checkbox"/> Lim.Max. Out.	Hi	<input type="checkbox"/> Contact Stop	S2
<input type="checkbox"/> Set-point	SP	<input type="checkbox"/> Lim.Min. Out.	Lo	<input type="checkbox"/> Contact SP1/SP2	S3
		<input type="checkbox"/> Cut-off	So	<input type="checkbox"/> Thermal contact	TK
<input type="checkbox"/> INPUT 4/20 mA				<input type="checkbox"/> Transducer Supply	24 Vdc / 40mA
<input type="checkbox"/> INPUT 0/5 Vdc		<input type="checkbox"/> Input IN1		<input type="checkbox"/> Potentiometer Supply	10Vdc / 5mA
<input type="checkbox"/> INPUT 0/10 Vdc		<input type="checkbox"/> Input IN2		<input type="checkbox"/> RL1	<input type="checkbox"/> 1/3 <input type="checkbox"/> 2/3

Charatteristics of the connected load

Manufacturer:		Type	<input type="checkbox"/> fans	<input type="checkbox"/> electric resistors
Electrical data		<input type="checkbox"/> VAC	<input type="checkbox"/> Amp	<input type="checkbox"/> Start Amp
		<input type="checkbox"/> Code		
Motor data		Anomaly electrical data		
Electrical connection	<input type="checkbox"/> star	<input type="checkbox"/> delta	phase R N	V
Traction	<input type="checkbox"/> direct	<input type="checkbox"/> belt driven	phase S N	V
Mechanics	<input type="checkbox"/> helical	<input type="checkbox"/> centrifugal	phase T N	V
Operator name:		Company stamp:		

