

VTS300 3-PHASE SLAVE REGULATOR

1. PREPARATIONS

1.1. Important

- Read these instructions carefully before installation.
- Before use, follow all the installation and electrical connection instructions.
- Keep these instructions with the regulator for future use.
- Observe current technical and safety regulations.
- The device must be professionally installed and commissioned by a qualified technician. INCORRECT installation may cause damages.
- Before turning on device power, always check that it is correctly grounded.
- DO NOT tamper with or REMOVE internal regulator components; this NULL AND voids THE WARRANTY and can cause damages.
- The user must be protected against electrical shock and the motor must be equipped with overload protection, as per current pertinent regulations.
- According to safety regulations, protection against any contact with live parts must be ensured by correct device installation; all parts that ensure protection must be secured so as irremovable without the help of a tool.
- DO NOT turn on the regulator without the protection lid.
- NEVER touch electrical circuit parts when the power is on.
- Install the regulator away from direct sunlight so as not to overheat the case.
- Make sure working conditions (working temperature, humidity, etc.) are within the indicated limits (see point 7).
- Do not install the device near heat sources (resistances, hot air ducts, etc.) where room temperature can exceed 50 °C, devices that generate strong magnetic fields, sites subject to rain, humidity, dust, excessive mechanical vibrations or shocks.

2. VTS300 REGULATOR UNIT DESCRIPTION

2.1. Overview

The VTS series three-phase regulators are built on a Vetronite(R) support in an IP55 grade GW PLAST box. The control zone is at the top of the board while the power zone is at the bottom. In addition to the M3 and M4 terminal boards, regulation, connection and signal devices are found in the control zone. The fan speed command varies according to the command signal received from the input. Output increases as input increases.

2.2. Key

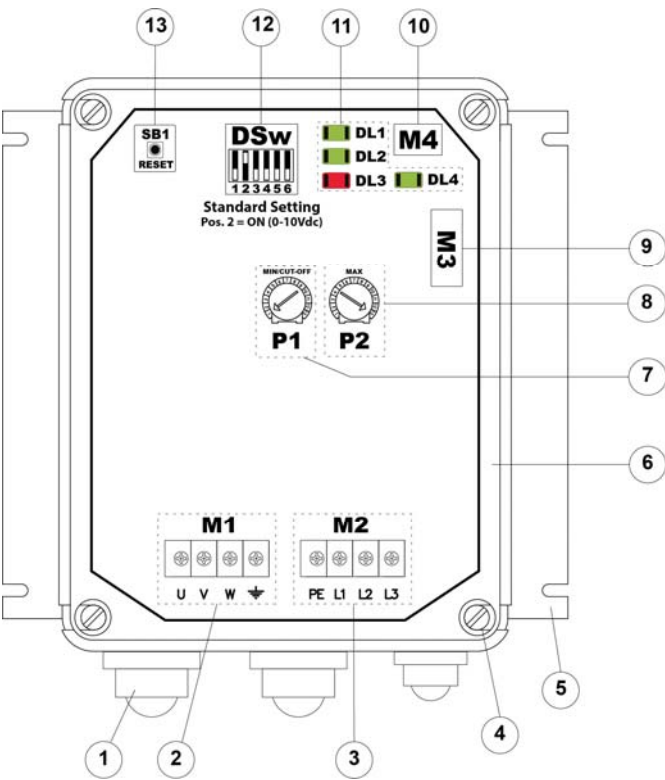

VTS300 key		
1	-	Wire clamps - connection wires
2	M1	Three-phase output terminal board (U-V-W) + load GND
3	M2	Three-phase power supply terminal board (L1-L2-L3) + PE
4	-	TPN lock screws with max 2.5 N m torque
5	-	Wall mount perforated fin
6	-	GW PLAST case
7	P1	Minimum voltage settings (MIN / CUT-OFF)
8	P2	Maximum voltage settings (MAX)
9	M3	Command input terminal board
10	M4	Alarm relay terminal board
11	DL..	Signal led
12	DSw	Programming dip switch (0-10Vdc std setting)
13	SB1	Reset button

2.3. Mechanical dimensions

Model	Plate data			Mechanical dimensions					Weight(*)
	A	kV A	IP	A	B	C	E	F	
VTS308	8	5.5	55	225	235	114	213	200	2.3
VTS312	12	8	55	225	230	128	213	200	2.5
VTS320	20	14	55	225	230	158	213	200	3.8

* Packaging included

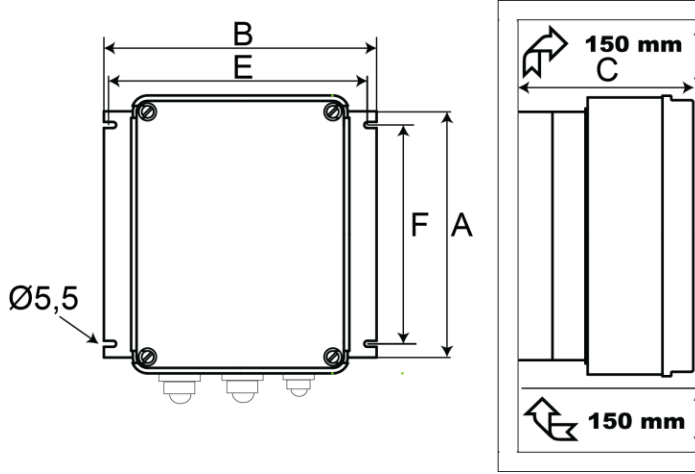

3. INSTALLATION

3.1. INSTALLATION

Vertically install the device with the wire inlet facing down. To permit correct heat dissipation, guarantee ≥150 mm clearance over and under the regulator. Reassemble and make sure the external protection lid is fully closed.

3.2. Electrical connections

Flexible wire section.
Signal: rated section 1.5 mm² (15 AWG)
Power: VTS 308 ≥ 1.5 mm² (15 AWG)
VTS 312 ≥ 2.5 mm² (13 AWG)
VTS 320 ≥ 4.0 mm² (11 AWG)

N.B. Protection devices: see point 8.

3.2.1. Power (M1) and load (M2*) connection:

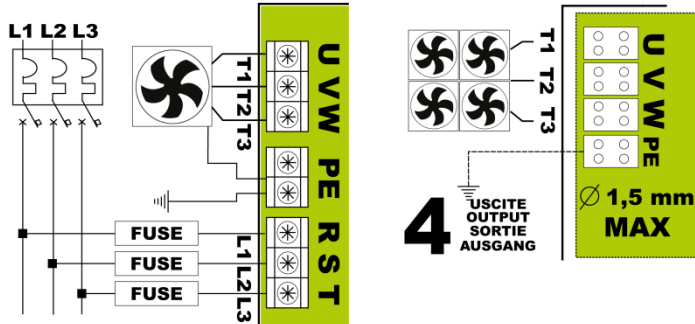

(*)The regulator can be set to directly connect no. 4 fans (Three-phase + Ground) upon request

3.2.2. Command signal connections (M3)

M3	Terminal	Label	Description
6	GND	Reference grounding	
5	S0	ON-OFF input (see point 3.3.3)	
4	VR	Reference voltage output +5.0 Vdc/+10.0 Vdc (±1.0%) (automatic switching)	
3	V+	Power supply voltage output +20 Vdc (±20%)	
2	GND	Reference grounding	
1	IN	Command signal input	

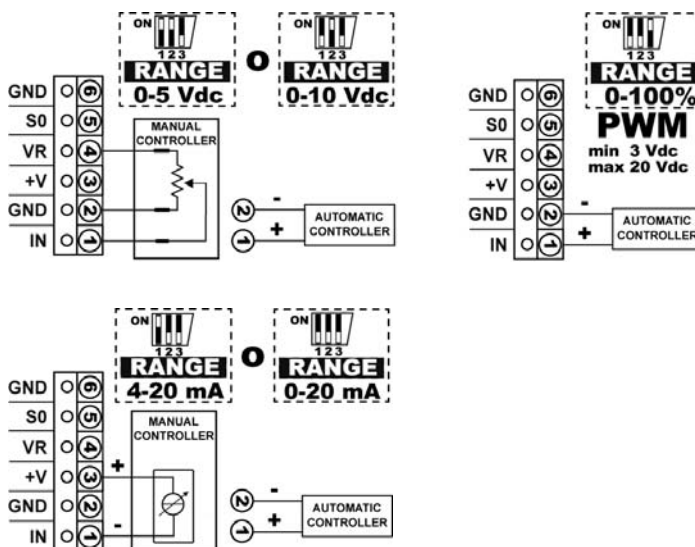

3.2.3. Alarm relay connection (M4)

Terminal	Label	Description
3	NO	Normally open contact
2	NC	Normally closed contact
1	COM	Shared terminal

3.3. Dip-Switch function settings (DSw1 – DSw6)

DSw	Description
1,2,3	Command signal selection (see point 3.3.2)
4	OFF = P1 (MIN) minimum voltage settings ON = P1 cut-off voltage settings
5,6	ON-OFF input function (see point 3.3.3)

3.3.1. Default settings



3.3.2. Command input function programming

WARNING Press button SB1 after changing DSw settings to apply changes..

DSw1	DSw2	DSw3	Description
OFF	OFF	OFF	0-20 mA signal
ON	OFF	OFF	4-20 mA signal
OFF	ON	OFF	0-10 Vdc signal
ON	ON	OFF	0-5 Vdc signal
OFF	OFF	ON	PWM signal
ON	ON	ON	Cos Phi calibration (reserved)

3.3.3. Functional programming for the ON-OFF input (S0)

DSw5	DSw6	Description
OFF	OFF	Start/Stop function (open = start)
ON	OFF	Thermal contact function (closed = start)
ON	ON	Output function at 100% (closed = 100%)
OFF	ON	Output function at MAX (closed = MAX (P2))

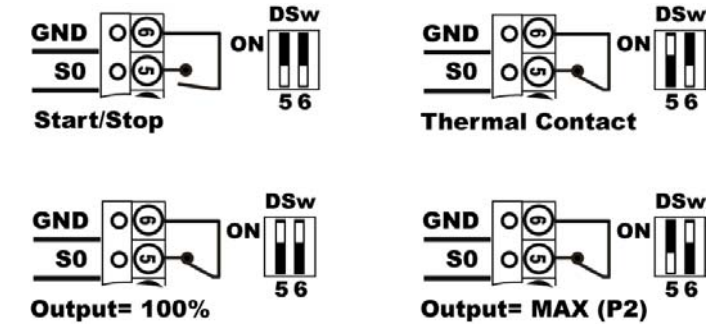

4. FUNCTIONAL CHARACTERISTIC

DSw 4 = ON (factory setting)

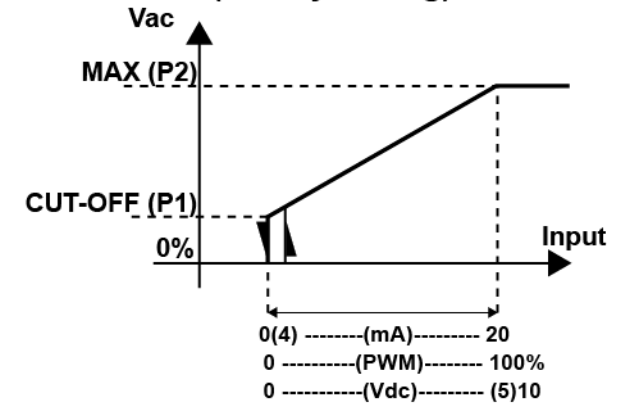

DSw 4 = OFF

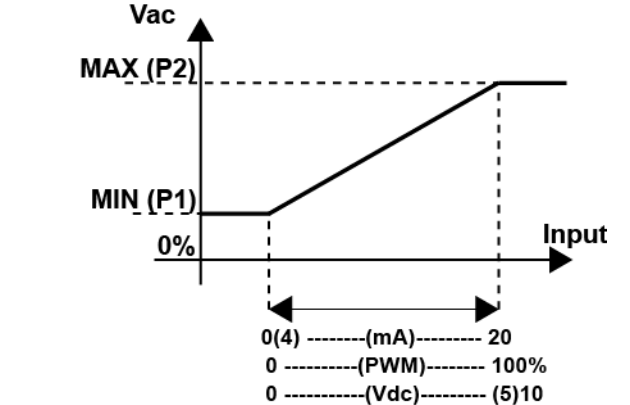

VTS300 3-PHASE SLAVE REGULATOR

5. Trimmer Regulation limits

5.1. Regulation limits

MIN & CUT-OFF

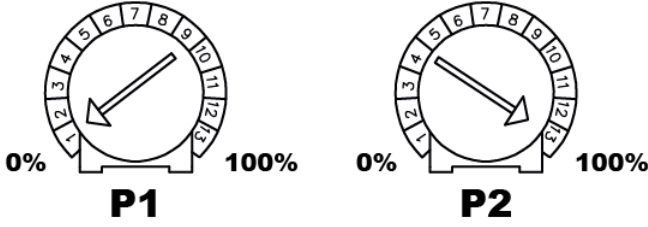

Trimmer	Label	Description
P1	MIN/ CUT-OFF	Use as minimum voltage (MIN) DSw4 = OFF (range from 0-100%). Turn P1 clockwise to the required minimum voltage.
		Use as CUT-OFF (shutdown point) DSw4 = ON (range from 0-100%). Once the minimum voltage is set, turn DSw4 ON and press SB1 (reset). Cut-Off will be set to minimum voltage.
P2	MAX	Maximum speed limit settings (range 0-100%).
		Settings procedure if maximum regulator speed input signal is not available: <ul style="list-style-type: none"> Remove signal connections from M3. Set the regulator in 0-10 Vdc mode (see point 3.3.2) Short circuit IN with VR (M3 terminals 1 and 4). The regulator runs at maximum speed. Turn P2 counter-clockwise to set the required maximum voltage.

6. SIGNALS

6.1. Led

LED	COLOR	LABEL	DESCRIPTION
DL1	GREEN	PWR	Power on (light on)
DL2	GREEN	CPU RUN	Microprocessor running (blinking light)
DL3	RED	FAIL	Fault alarm (blinking light) (see point 6.2)
DL4	GREEN	-	RL1 relay excited (light on)

6.2. Alarm blink code (DL3) in order of priority

NR. BLINKS	DESCRIPTION
1	Board temperature over limit (> 85 °C)
2	Phase loss
3	T.K. contact open (DSw5 = ON and DSw6 = OFF)
4	Input signal over range
5	Input signal under range
6	Incorrect dip switch settings

7. TECHNICAL SPECIFICATIONS

Power supply:

Voltage: 400 Vac (±10%) three-phase (230 Vac upon request).

Frequency: 50/60 Hz automatic frequency recognition

Surge: for installation category II (4 kV)

(> 500 Vac surge filters ON).

Mains: monitoring on all 3 phases.

Ground connection:

VTS300 controllers are compatible with the different Ground connections: IT – TT – TN.

Current:

Rated RMS current @ 50 °C room temperature:

VTS308: 8 A < 50 °C; > 50 °C -0.6 A/°C

VTS312: 12 A < 50 °C; > 50 °C -0.6 A/°C

VTS320: 20 A < 50 °C; > 50 °C -0.6 A/°C

Overload: 150% of rated current (=10" every 3')

Power:

Command: 5 V A

Dissipated in. 4 W/A:

VTS308 32 W @ 8 A

VTS312 48 W @ 12 A

VTS320 72 W @ 20 A

Functional characteristic: SLAVE regulator

Direct function; output increases as input increases

Input signals and contacts:

Analog: 0-10 Vdc, 0-5 Vdc (Ri = 10 kΩ)

0-20 mA, 4-20 mA (Ri = 100 Ω)

Logic: PWM signal from 3 to 20 Vdc with positive polarity

"ON/OFF" clean contact: S0 programmable contact (see point 3.3.3).

Output signals and contacts:

Auxiliary power:

20 Vdc (±20%), ≤ 20 mA not stabilized and protected against short circuit

5.0 Vdc/10.0 Vdc (±1.0%), ≤ 20 mA protected against short circuit

RL1 relay: COM, NC, NO contacts for alarm

3 A @ 250 Vac – 3 A @ 30 Vdc

Alarms:

In command: 0-5 Vdc: Vin ≤ 5.5 Vdc; 0-10 Vdc: Vin ≤ 11 Vdc

0-20 mA: Iin ≤ 24 mA; 4-20 mA: 2 mA ≤ Iin ≤ 24 mA

Mains monitoring: phase loss

Regulator: working temperature control with internal probe

(< 85 °C).

Protections:

Surge: As per EN 61000-4-5: surge category II (4 kV)

Auxiliary power: with PTC sensor for short circuit protection

Internal temperature: internal thermal protection

Case:

Material: GW-PLAST 75 (temperature < 85 °C) and aluminum

Pollution: for high pollution using the wire clamp kit

Fire resistance: category D

Insulation:

Case: class I (use of grounded PE protection)

Command: 4000 Vac between command input and mains voltage parts

Working conditions:

Working temperature: from -20 °C to 50 °C ; use

Start/Stop contact if T ≤ -10 °C

Storage temperature: from -20 °C to 70 °C

Humidity: from 0% to 85% non-condensing relative humidity

Vibrations: ≤ 1 g (9.8 m/s²)

Assembly:

Assembly: wall mount in vertical position only.

8. CIRCUIT BREAKER AND SHORT CIRCUIT PROTECTION

A short circuit and/or overload device must be installed upstream from the VTS308, VTS312 or VTS320 regulator; this protection must be supplied by the installer and can be made up of:

- Three-phase circuit breaker with 'AC' cut-off curve
- Triple ultra-fast fuses, to protect semi-conductors

Model	Circuit breaker	Protection fuses - SRC			
		Type	Vac	Amp	P/N
VTS308	16 A	10x38	690	16	FR10GB69V16
VTS312	24 A	10x38		16	FR10GB69V16
VTS320	40 A	14x51		25	FR10GB69V25

The use of these protections safeguard regulation device electrical integrity.

SURGE ARRESTER :

Electrical protection inserted between the regulator power supply and grounding, that protects the device from transitory power surges up to 480 Vac.

WARNING:

Disconnect the faston contact from the PE ground reference, in the electrical rigidity test.

WARNING:

For DIFFERENTIAL protection systems, use components with grounded current dispersion ≥ 60 mA.

The VTS300's dispersion current to Ground, it's about 4 mA

The following table shows the measured values:

Supplied phases	Current (mA)	Regulation output
L1 – L2 – L3	< 4	0%
L1 – L2 – L3	< 4	100%
L1 – L2 – L3	< 13	15%
L1 – L2	< 8	0%
L2 – L3	< 8	0%
L1 – L3	< 8	0%
L1	< 12	0%
L2	< 12	0%
L3	< 12	0%

9. MANUFACTURER'S DECLARATION

This instrument was designed and constructed for use in Industrial environments and meets the following community directives:

- Machinery Directive 2006/42/CE as amended
- Low Voltage Directive 2006/95/CE and 93/68/CE
- EMC 2004/108/CE directive as amended

10. COMMUNITY DIRECTIVES AND TECHNICAL STANDARDS

The essential directive requirements are met by compliance with "generic standards" for the industrial environment.

Directive	Code Standard	Description
2006/42/CE	EN 60204-1	Machine safety and electrical system
2006/95/CE	EN 60204-1	Machine safety and electrical system
	EN50178	Power installation electronic equipment
2004/108/CE	EN61800-3	Variable speed electric drives. Part 3 : Product standard for Electromagnetic compatibility and specific test methods

With reference to EMC compatibility, according to markings:



11. CODE

ZN VTS	a	bb	cc	d	e	f	g	h	i
POSITION	a	bb	cc	d	e	f	g	h	i
EXAMPLE	ZNVTS	3	12	40	1	0	0	S	0 0
Position	Description								
a	power type	3	three-phase						
bb	Rated current	08	8 A						
		12	12 A						
		20	20 A						
cc	power supply voltage	40	400 Vac (±10%) - 50/60 Hz						
d	motor outputs	1	1 motor outputs						
		4	4 motor outputs						
e	not used	0	-						
f	not used	0	-						
g	case protection grade	S	IP55						
		G	IP20						
h	customizations	0	Selpro standard version						
i	revision index	0	Global product update index						



The instrument must be disposed of according to local electric and electronic device disposal regulations.